



ShaanXi DongXin HengKe Electronics Co., LTD

陕西东芯恒科电子有限公司

SMD QUARTZ CRYSTAL RESONATOR

SMD X'TAL 2.55×2.05×0.60mm

Applications

GPS Auto Monitoring electronics

Features

Dimensions: 2.55 x 2.05 x 0.60 mm

Reflow soldering is available

Extremely good for reducing EMI effect

High resolution frequency tolerance is obtained.



Specifications

Project	项目	SPECIFICATION 规格
Frequency Range	频率范围	12M~60MHz
Operation Mode	振动模式	Fundamental
Loading Capacitance	负载电容	9pF Std. 8 to 22pF, Series available
Drive Level	激励电平	10μW (100μW Max)
Frequency Tolerance	频率偏差	±10ppm ~±30PPM (at 25°C)
Equivalent Resistance	谐振电阻	See Below
Frequency Stability	频率稳定性	±10ppm ~±50PPM
Operating Temp. Range	工作温度范围	-10 ~+60°C to -40~+85°C
Storage Temp. Range	储存温度范围	-55 ~ +125°C

Table 1: Operating temperature range and frequency stability

Operation Temperature Range	Frequency Stability				
	±10PPM	±15PPM	±20PPM	±30PPM	±50PPM
-10°C~+60°C	●	●	●	●	●
-20°C~+70°C	●	●	●	●	●
-40°C~+85°C	○	●	●	●	●

Table 2: Equivalent series resistance

Frequency (MHz)	Overtone Order	ESR (Ω MAX)
12-21.999MHz	Fundamental	80Ω(MAX)
22-24.999MHz	Fundamental	70Ω(MAX)
25-29.999MHz	Fundamental	60Ω(MAX)
30-60.000MHz	Fundamental	50Ω(MAX)

Dimensions and Patterns [unit:mm]

Dimensions (unit: mm)

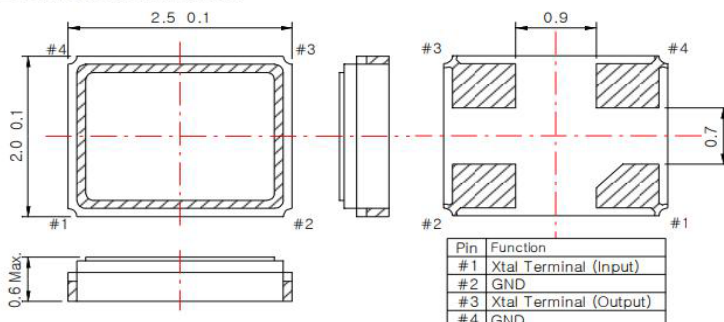

Land pattern (unit: mm)

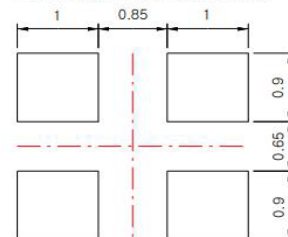

SMD QUARTZ CRYSTAL RESONATOR

SMD X'TAL 2.5×2.0×0.6mm

Taping Specification(Unit: mm)

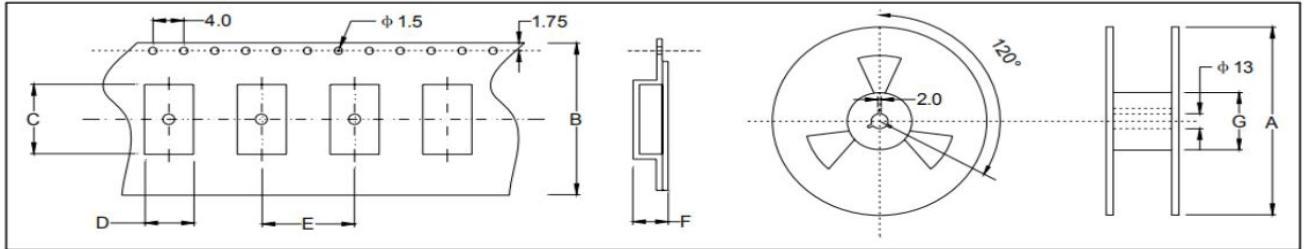

	A	B	C	D	E	F	G
SMD2520	178±2.0	8.0±0.3	2.70±0.05	2.25±0.05	4.0±0.1	0.65±0.05	60.5±1.0
3000 pcs per reel							

REFLOW SOLDERING PROFILE

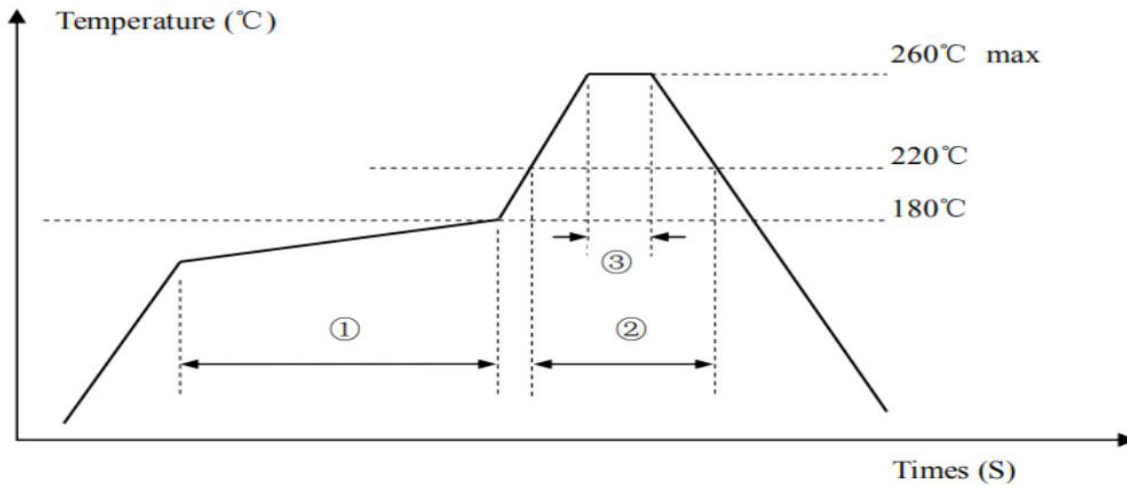

Pb free reflow A	①	Preheat	160~180°C	120sec. max
	②	Primary heat	220°C	60sec. max
	③	Peak	260°C	10sec. max.