

VD7PA多点联动 VD7PA Multi-drive

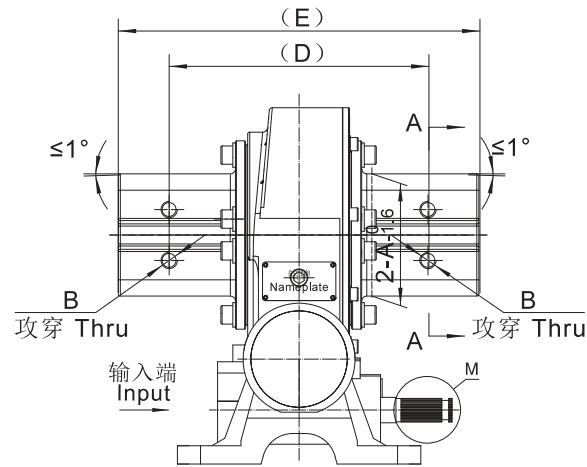

输出端方案见表1
The output scheme is shown in Table 1

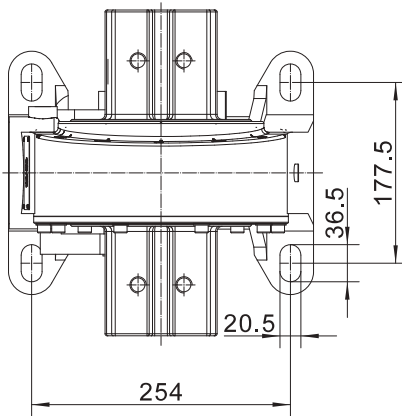
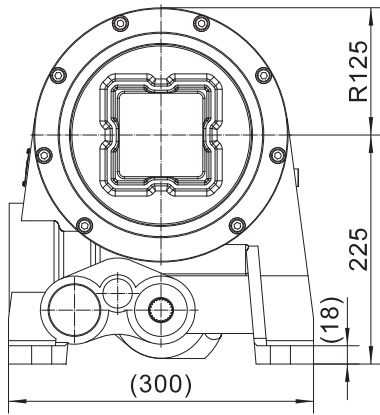
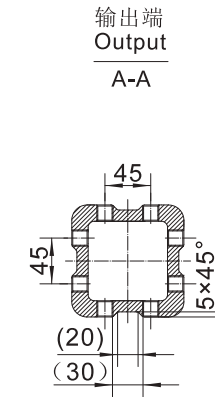
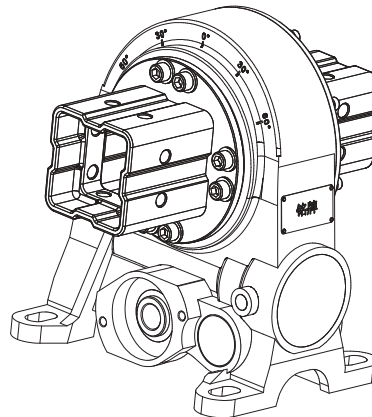

输入端
Input
1:1

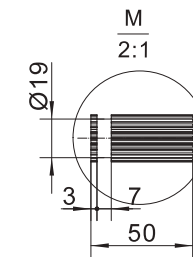
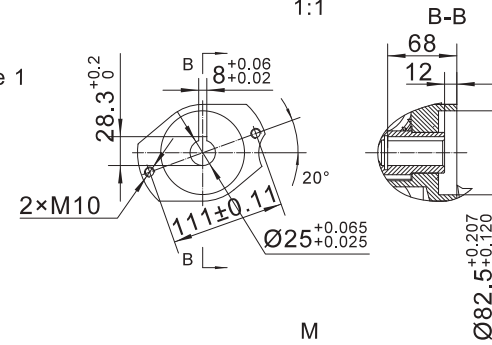

VD7PA		回转驱动性能参数 Slewing Drive Performance Parameters	
减速比	Gear Ratio	60:1	
倾覆力矩	Tilting Moment	8 kN.m	5.9x10 ³ lbf.ft
保持力矩	Holding Torque	39 kN.m	28.8x10 ³ lbf.ft
输出转矩	Output Torque	6.1 kN.m	4.5x10 ³ lbf.ft
输出转速	Output Speed	<2.5rpm	
限位角	Limit Angle	50°/55°/60°/65°/70°	
机械效率	Mechanical Efficiency	35%±3%	
自锁性	Self-locking	可靠的静态自锁 Static self-locking	
精度	Precision	≤0.2°	
防护等级	IP Class	IP65	

SH029		
电机性能参数 Motor performance parameters		
额定电压	Rated Voltage	24V
额定电流	Rated Current	<8A
额定转矩	Rated Torque	66N.m
额定转速	Rated Speed	12rpm
输入功率	Input Power	190W
环境温度	Ambient Temp	-40℃~+60℃
噪音	Noises	≤65dB
IP等级	IP Class	IP65

表1
Table 1

方管 Square Tube	A	□92	□110	□112	□118	□118.5	□119.5	□120
	B	4xM20-6AZ	8xM16-6AZ	8xM16-6AZ	8xM16-6AZ	8xM16-6AZ	8xM16-6AZ	8xM16-6AZ
	C	-	45	45	50	50±0.3	50±0.3	50
	D	255	255	255	255	265	265	255
	E	355	355	355	355	365	365	355
方管 Square Tube	A	□120.5	□121.5	□122	□123	□130	□138	□140
	B	8xM16-6AZ	8xM16-6AZ	8xM16-6AZ	8xM16-6AZ	8xM16-6AZ	8xM16-6AZ	8xM16-6AZ
	C	50±0.3	50±0.3	50	50	60	70	70
	D	265	265	255	255	275	275	275
	E	365	365	355	355	375	375	375
圆管 Circular Tube	A	Ø119						
	B	8xM16						
	C	-						
	D	255						
	E	355						

- A: 方管大小 Square tube size
 B: 螺纹孔大小和个数 Size and number of threaded holes
 C: 螺纹孔间距 Threaded hole spacing
 D: 装置两侧螺纹孔间距 Threaded hole spacing on both sides of the slewing drive
 E: 装置输出总长 Total output length of the slewing drive

如果需要异型输出法兰, 请联系尚驰销售人员
 Contact Sunslew if irregular output flange is required.

