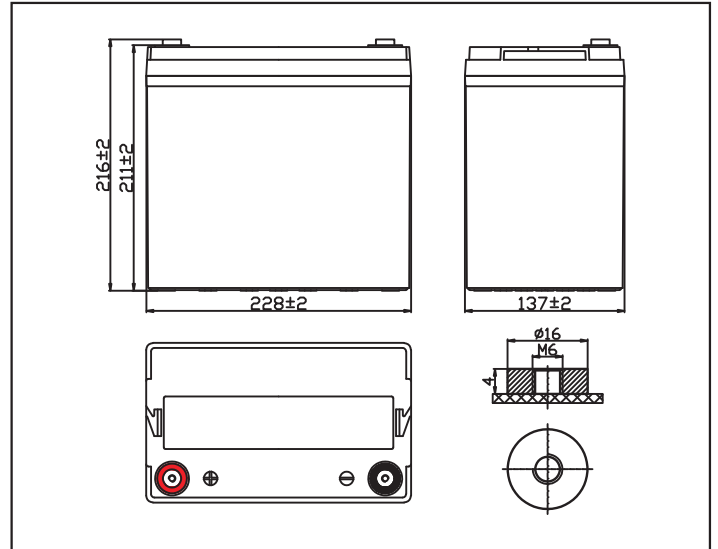

MODEL: OT55-12(GEL)/CL
NO.: 302020001-00036

Plane Chart:

Unit:(mm) Terminal type:(T1)

Parameter Chart:

Volts		12V	
Capacity(25°C)	10 hours rate (5.5A)	55Ah	
Discharge Current Testing (25°C)	1 hours rate (30.2A)	31Ah	
	3 hours rate (13.7A)	42Ah	
Internal Resistance	Full Charged Battery 25°C	8mΩ	
Capacity Affected By Temperature	40°C	104%	
	25°C	100%	
	0°C	83%	
	-15°C	65%	
Residual Capacity (25°C)	Capacity After 3 Months Storage	91%	
	Capacity After 6 Months Storage	82%	
	Capacity After 12 Months Storage	65%	
Charge (Constant Voltage)	Cycle (25°C)	Initial Charging Current Less Than 16.5A Voltage 14.5~14.9V	
	Float (25°C)	Charge Voltage 13.6~13.8V	
Weight (Approx)		16.8Kg	

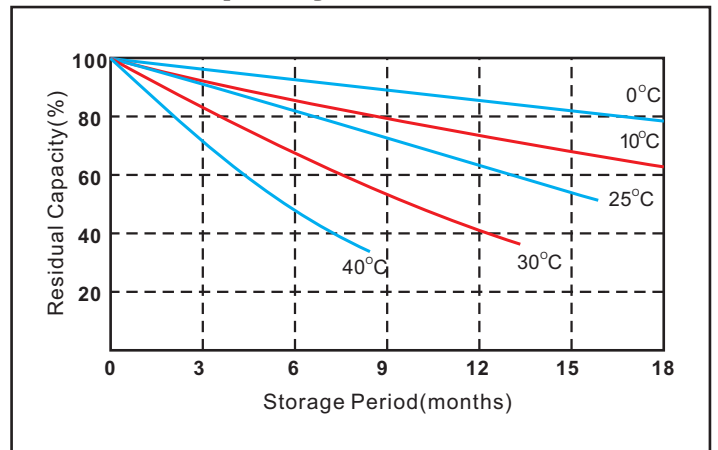
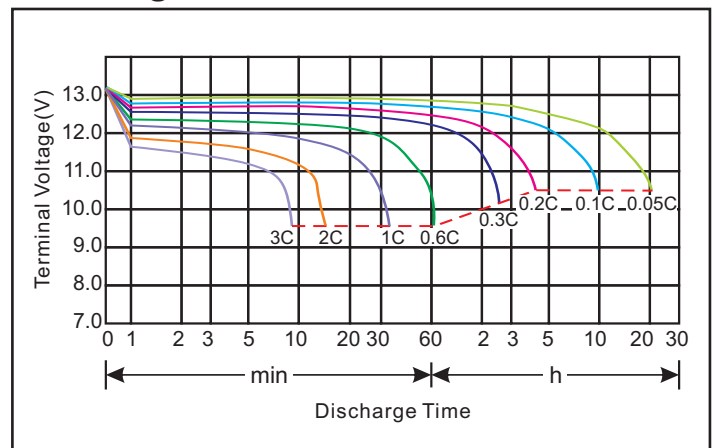
Residual Capacity

Discharge Current 25°C

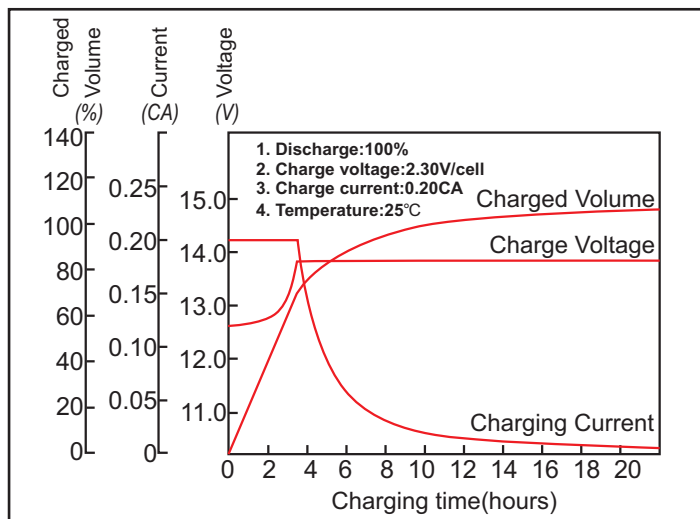
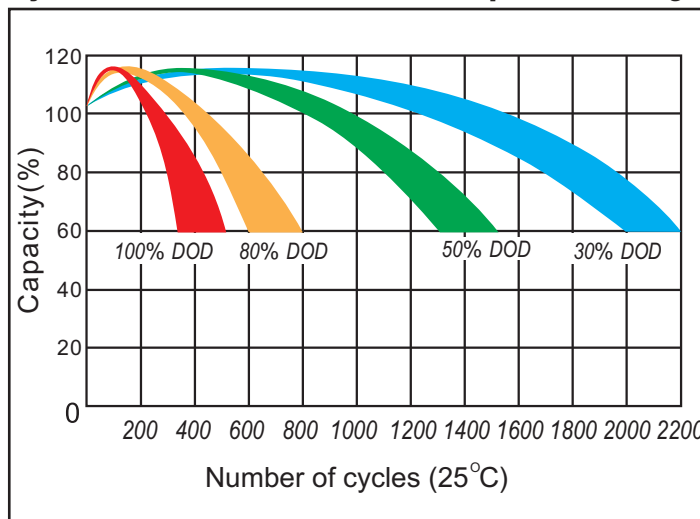
★The above are average and data obtained from the first 3 charge/discharge cycles. These are not minimum values.

MODEL: OT55-12(GEL)/CL
NO.: 302020001-00036
Constant voltage charging characteristics

Cycle service life in relation to the depth of discharge

Constant Current Discharge Characteristics (A, 25°C)

F.V/Time	5min	10min	15min	30min	60min	2h	3h	5h	8h	10h	20h
9.60V	185.4	131.5	97.2	60.2	30.8	20.1	13.8	9.2	6.5	5.5	2.9
10.2V	169.6	121.6	93.2	58.3	29.7	19.8	13.7	9.1	6.4	5.4	2.9
10.5V	157.8	112.5	91.3	56.4	28.5	19.6	13.2	8.9	6.3	5.3	2.8
10.8V	148.3	106.3	88.4	53.9	27.6	19.4	12.6	8.7	6.2	5.3	2.8

Constant Power Discharge Characteristics (Watt, 25°C)

F.V/Time	5min	10min	15min	30min	60min	2h	3h	5h	8h	10h	20h
9.60V	1946.7	1470.2	1065.2	676.4	395.8	222.5	166.3	113.2	74.8	64.7	34.5
10.2V	1848.6	1345.6	1021.1	650.5	379.8	219.5	164.3	112.2	74.1	64.1	34.4
10.5V	1735.8	1260.5	1000.1	636.6	359.7	216.5	162.3	111.2	73.6	64.0	34.4
10.8V	1646.1	1206.8	968.0	616.5	359.7	214.4	160.3	110.2	72.7	63.8	34.3

Capacity Factors With Different Temperature

Battery Type		-20°C	-10°C	0°C	5°C	10°C	20°C	25°C	30°C	40°C	45°C
GEL Battery	12V	50%	70%	83%	85%	90%	98%	100%	102%	104%	105%

★The above are average and data obtained from the first 3 charge/discharge cycles. These are not minimum values.