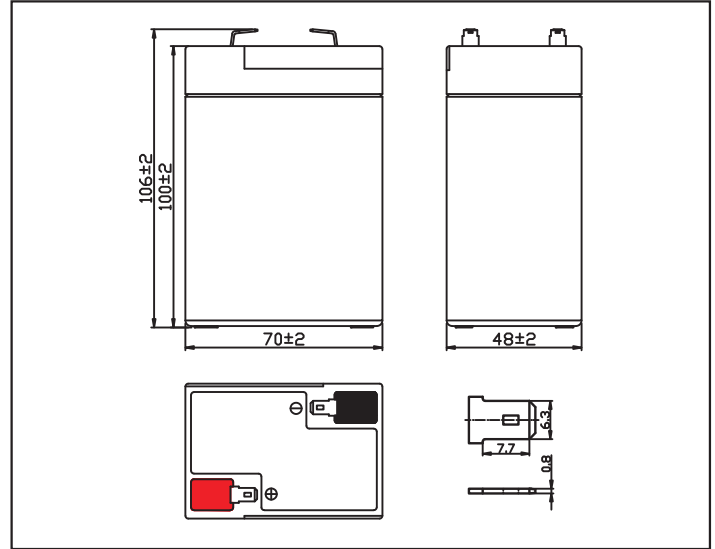

MODEL: OT4.5-6
NO.: 302010005-00236

Plane Chart:

Unit:(mm) Terminal type:(F2)

Parameter Chart:

Volts		6V	
Capacity(25°C)	20 hours rate (0.225A)	4.5Ah	
Discharge Current Testing (25°C)	20 I ₂₀ rate (4.5A,27min)	29min	
	60 I ₂₀ rate (13.5A,7min)	7min	
Internal Resistance	Full Charged Battery 25°C	20mΩ	
Capacity Affected By Temperature	40°C	104%	
	25°C	100%	
	0°C	83%	
	-15°C	65%	
Residual Capacity (25°C)	Capacity After 3 Months Storage	91%	
	Capacity After 6 Months Storage	82%	
	Capacity After 12 Months Storage	65%	
Charge (Constant Voltage)	Cycle (25°C)	Initial Charging Current Less Than 1.35A Voltage 7.25~7.45V	
	Float (25°C)	Charge Voltage 6.8~6.9V	
Weight (Approx)		0.68Kg	

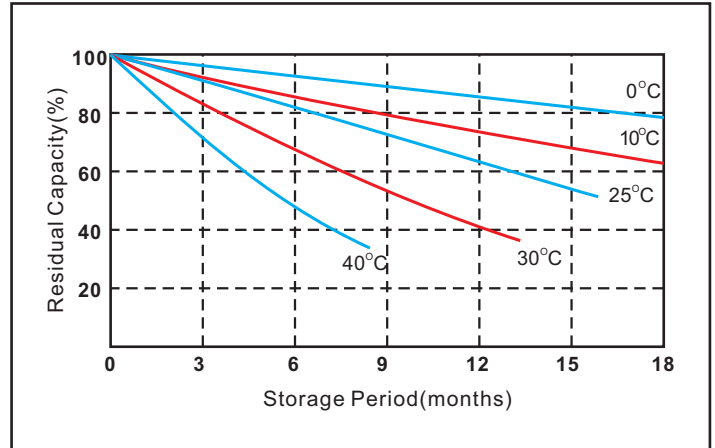
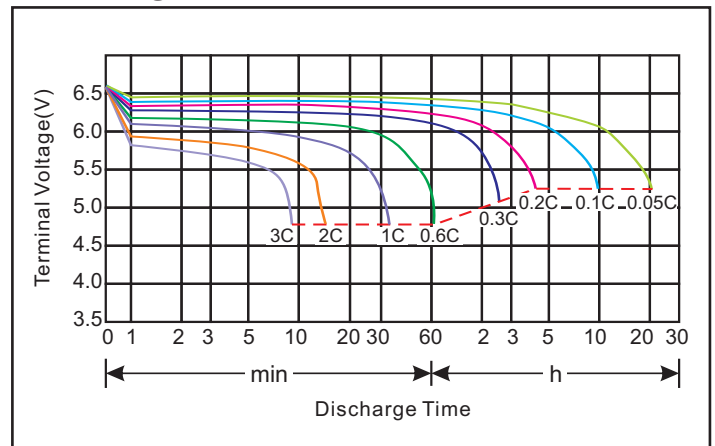
Residual Capacity

Discharge Current 25°C

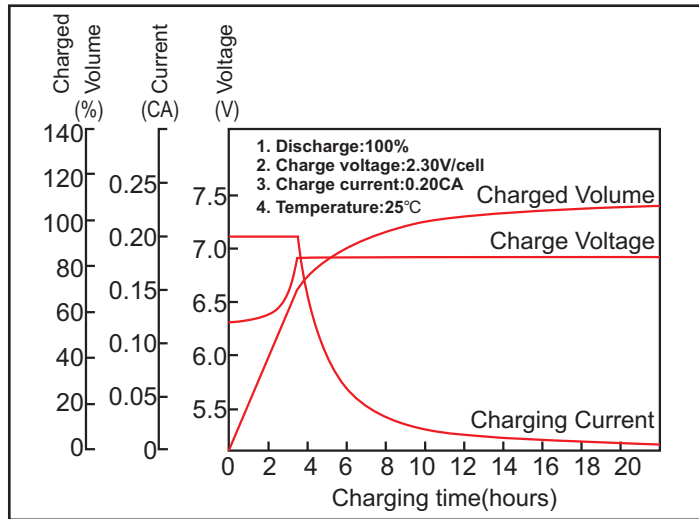
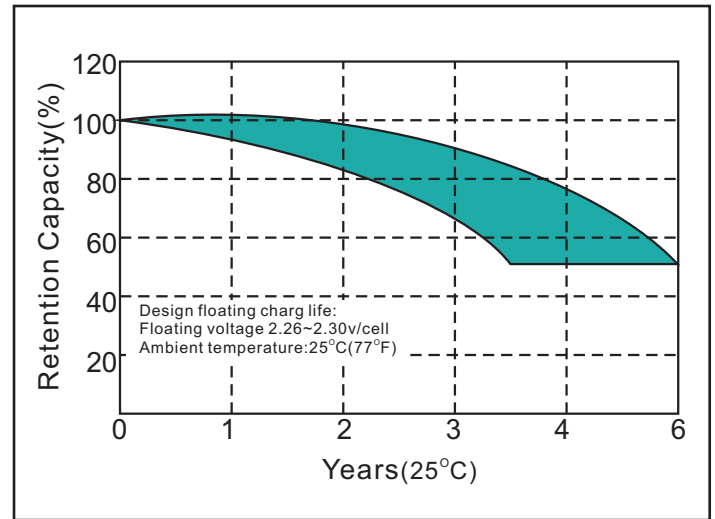
★The above are average and data obtained from the first 3 charge/discharge cycles. These are not minimum values.

MODEL: OT4.5-6
NO.: 302010005-00236
Constant voltage charging characteristics

Float Life

Constant Current Discharge Characteristics (A, 25°C)

F.V/Time	5min	10min	15min	30min	60min	2h	3h	5h	8h	10h	20h
4.80V	12.84	8.19	6.63	4.02	2.34	1.36	1.06	0.74	0.47	0.37	0.226
5.10V	10.90	7.78	6.37	3.92	2.25	1.33	1.04	0.73	0.46	0.37	0.225
5.25V	9.98	7.53	6.22	3.82	2.19	1.30	1.02	0.72	0.45	0.36	0.225
5.40V	9.15	7.29	6.04	3.71	2.14	1.27	1.00	0.71	0.44	0.35	0.216

Constant Current Discharge Characteristics (Watt, 25°C)

F.V/Time	5min	10min	15min	30min	60min	2h	3h	5h	8h	10h	20h
4.80V	76.28	49.11	39.90	24.86	14.38	8.41	5.95	4.17	2.91	2.42	1.34
5.10V	73.92	47.47	39.00	24.07	13.80	8.30	5.90	4.11	2.85	2.35	1.34
5.25V	72.26	46.40	38.35	23.67	13.58	8.28	5.89	4.09	2.87	2.37	1.34
5.40V	70.56	45.30	37.69	23.26	13.24	8.17	5.84	4.04	2.83	2.32	1.29

Capacity Factors With Different Temperature

Battery Type		-20°C	-10°C	0°C	5°C	10°C	20°C	25°C	30°C	40°C	45°C
Battery	6V	50%	70%	83%	85%	90%	98%	100%	102%	104%	105%

★The above are average and data obtained from the first 3 charge/discharge cycles. These are not minimum values.