



# DW9828N

## eOIS Driver with Digital Controller & Internal Hall

### Overview

The DW9828N is motor driver for camera auto focus. DW9828N includes internal hall, digital PID controller, 32 byte EEPROM for user, 1 channel H-bridge, A/D converter and D/A converter for driving of internal Hall sensor.

The DW9828N operates from a single 2.65V to 3.6V supply. It is controlled via an I<sup>2</sup>C serial interface that operates at clock rate up to 3.4MHz.

The DW9828N can be used for auto focus applications in mobile cameras, digital still cameras, camcorders, web cameras and action cameras.

### Features

- Supply voltage: 2.65V to 3.6V
- Fast Mode, Fast Mode plus and HS mode I<sup>2</sup>C Interface
- 1.2V I<sup>2</sup>C Interface available
- Reverse I<sup>2</sup>C interface available
- H-Bridge driver
- Hall sensor calibration
- Internal FRA test mode
- Internal Loop Gain adjust
- Internal AF settling time measure
- Coil resistance measure
- High resolution Analog-to-Digital Converter (ADC)
- PID Controller
- PKG: 6 pins WLCSP (0.620mm X 1.840mm X 0.335mm)

### Applications

- Mobile cameras
- Digital still cameras
- Camcorders
- Web cameras and action cameras

## Simplified Application Diagram

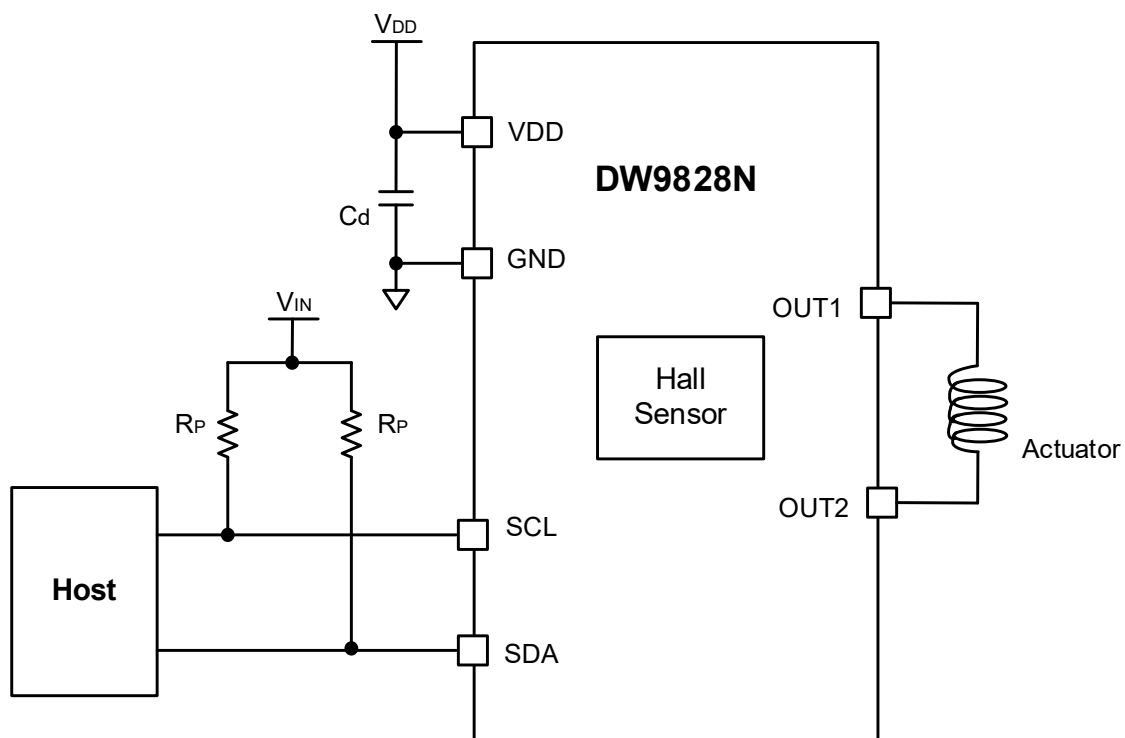

Figure 1. Simplified Application Diagram

## **Important Notice**

Halo Microelectronics reserves the right to modify, improve, and terminate its products, services, documentations, etc. without advance notice. Customers are encouraged to contact Halo Microelectronics sales representatives to get the latest product information.

Without proper legal authorization, Halo products shall not be used for medical or military applications. Halo Microelectronics does not assume any liability of personal or property damages of any kind due to such applications.

All text, images, trademarks of this document, and any intellectual property contained in the product and in this document belong to Halo Microelectronics Co. Ltd. No part of this document may be used, copied, modified, distributed, or published without legal authorization from Halo Microelectronics.

© 2024 Halo Microelectronics. All rights reserved. [www.halomicro.cn](http://www.halomicro.cn)