

HL8545/G

Automotive Quad Channels 50mΩ High Side Switch

Overview

The HL8545/G are quad-channel, high side power switch with an integrated NMOS power FET and charge pump. The device integrates advanced protective functions such as load current limitation, overload active management by power limitation and overtemperature shutdown with configurable latch-off. Full diagnostics and high-accuracy current sense features enable intelligent control of the load. In reverse battery condition, the HL8545 need external ground diode to block the reverse current from ground to battery. While the HL8545G needn't such ground diode.

An active drain and source voltage clamp is built into address switching off the energy of inductive loads, such as relays, solenoids, pumps, motors, and so forth. During the inductive switching-off cycle, both the energy of the power supply (EBAT) and the load (ELOAD) are dissipated on the high-side power switch itself. With the benefits of process technology and excellent IC layout, the HL8545/G can achieve excellent power dissipation capacity, which can help save the external free-wheeling circuitry in most cases.

The HL8545/G can be used as a high-side power switch for a wide variety of resistive, inductive, and capacitive loads, including the low-wattage bulbs, LEDs, relays, solenoids, and heaters.

This device operates over a -40 °C to +150 °C junction temperature.

HL8545/G are available in a 16-pin DFN package.

Features

- Quad channels high side power switch with full diagnostics
- Operating voltage range, 4 V ~ 28 V
- Very-low standby current, <0.5 μA
- AEC-Q100 Qualified:
 - Device temperature grade 1: -40°C to 125°C
 - Operating junction temperature, -40°C to 150°C
- 3.3 V and 5V compatible control logic
- High-accuracy current sense, ±10% at 4.5 A
- Protections
 - Overload and short-circuit protection
 - Inductive load negative voltage clamp
 - Undervoltage lockout (UVLO) protection
 - Thermal shutdown/swing protection
 - Pin configurable latch-off or auto-retry mode on overtemperature event
 - Loss of GND, loss of supply protection
- Reverse battery protection
 - HL8545, with external ground diode
 - HL8545G, without external ground diode
- Current Sense diagnostic functions
 - OFF-state open load detection.
 - Overload and short to ground detection
 - Short to Battery detection
 - Thermal shutdown/swing detection
- Diagnostic function can be enabled or disabled
- 5mm x 6mm, 16 Pin DFN package

Applications

- High-side power switch for sub-module
- Power switch for low-wattage lamp
- High-side relays and solenoids
- General resistive, inductive, and capacitive loads

Typical Application Diagram

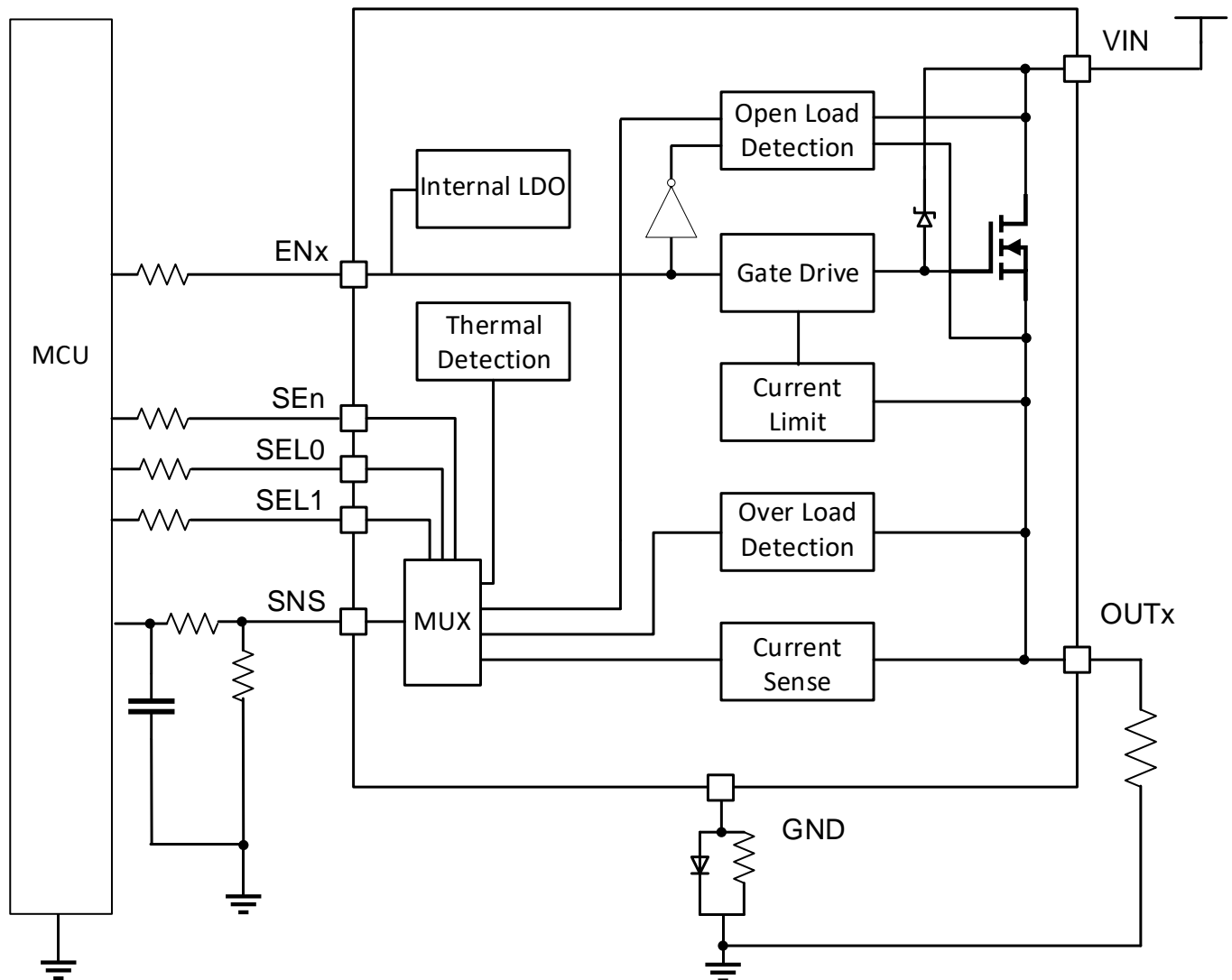

Figure 1. Simplified Application Diagram

Ordering Information

| Part Number | Package | Operation Ambient Temp |
|---------------|-----------------------|------------------------|
| HL8545FN01Q1 | 5mm x 6mm, 16 Pin DFN | -40 °C to 125 °C |
| HL8545GFN01Q1 | 5mm x 6mm, 16 Pin DFN | -40 °C to 125 °C |

Important Notice

Halo Microelectronics reserves the right to modify, improve, and terminate its products, services, documentations, etc. without advance notice. Customers are encouraged to contact Halo Microelectronics sales representatives to get the latest product information.

Without proper legal authorization, Halo products shall not be used for medical or military applications. Halo Microelectronics does not assume any liability of personal or property damages of any kind due to such applications.

All text, images, trademarks of this document, and any intellectual property contained in the product and in this document belong to Halo Microelectronics Co. Ltd. No part of this document may be used, copied, modified, distributed, or published without legal authorization from Halo Microelectronics.

© 2023 Halo Microelectronics. All rights reserved. www.halomicro.cn