

AP-3L 系列 / AP-3L SERIES



PRODUCT INFORMATION/ 产品信息

Pump Design/产品名称: Diaphragm Air Pump/隔膜气泵
 Insulation/绝缘等级: Class B
 Net Weight/产品净重: 0.160Kg
 Outlet Connector/出水接口: Barb port/倒扣

LABORATORY TEST CONDITION/ 工作条件

- Ta within 60°C, Tf within 70°C / Ta: 60°C 以下, Tf: 70°C 以下
- ED 100% or work as specified /连续工作或按指定工作方式
- Ta: Ambient temperature / Ta: 环境温度
- Tf: Temperature of fluid water / Tf: 流体温度

APPLICATIONS/ 应用领域

Vacuum Food Packing Machine、Vacuum Table Blender
 真空食物包装机、真空果汁机

型号 / Model	AP-3L
最大吸气负压 / Max suction pressure	≤ -0.80bar
气流量 / Air flow (LPM)	≥ 8.5
功率 / Power (W)	12
噪音 / Noise (dB)	< 73
工作方式 / Duty Cycle	ED 100% or work as specified / 连续工作或按指定工作方式
电压规格 / Voltage	DC 6 ~ 24V
产品认证 / Product Certificate	RoHS、FDA、REACH

Performance Curve/ 性能曲线

测试条件: 周围温度 (20°C ± 5°C), 相对湿度 (65% ± 15%),
 使用流体 (室温空气); 测试电压 (DC 12V)

Test Condition: Ambient temperature (20°C ± 5°C), Relative humidity (65% ± 15%)
 Use liquid (Room-Temperature Air), Test voltage: (DC 12V)

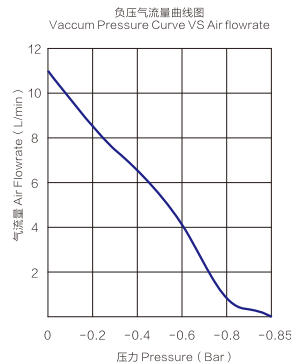
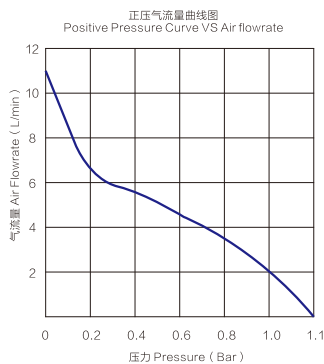

Mechanical Drawing & Dimension/ 外型尺寸

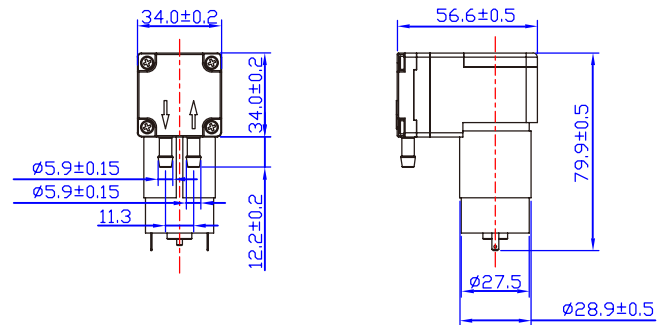

Dimensions/ 单位: millimeters/ 毫米