

# DP-11 系列/DP-11 SERIES



## PRODUCT INFORMATION/ 产品信息

Pump Design/产品名称: Solenoid(Piston) Pump/电磁隔膜水泵  
 Insulation/绝缘等级: Class H  
 Net Weight/产品净重: 0.05Kg  
 Outlet Connector/出水接口: Barb port/倒扣

## LABORATORY TEST CONDITION/ 工作条件

- Ta within 80°C, Tf within 35°C / Ta: 80°C以下, Tf: 35°C以下
- ED100%: work continuously / ED100%: 持续工作
- Ta: Ambient temperature / Ta: 环境温度
- Tf: Temperature of fluid water / Tf: 流体温度

## APPLICATIONS/ 应用领域

Steam Iron、Garment Cleaner、Steam Cleaner  
 蒸汽熨斗、蒸汽刷、蒸汽挂烫机

型号 / Model	DP-11 ( 01 )	DP-11 ( 02 )	DP-11 ( 03 )
流量 / Flowrate (ml/min)	15	30	45
最大压力 / Max Pressure(bar)	0.2	0.3	0.35
功率 / Power(W)	7		
噪音 / Noise(dB)	50		
工作方式 / Duty Cycle	ED 100% / 连续工作		
电压规格 / Voltage	220-240V/50-60Hz, 120V/60Hz, 100V/50-60Hz		
产品认证 / Product Certificate	TUV、CQC、UL		

## Performance Curve/ 性能曲线

测试条件: 水温20°C, 室温25°C。所有参数公差为 ± 15%, 仅供参考。  
 Test Condition: Water temperature 20°C, Indoor temperature 25°C. The tolerance range of all the parameters is ± 15%. Just for reference.

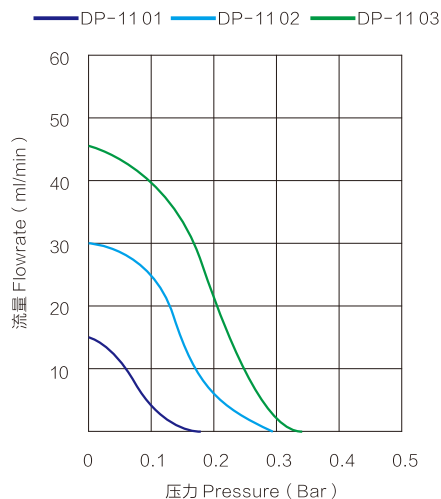

## Mechanical Drawing & Dimension/ 外型尺寸

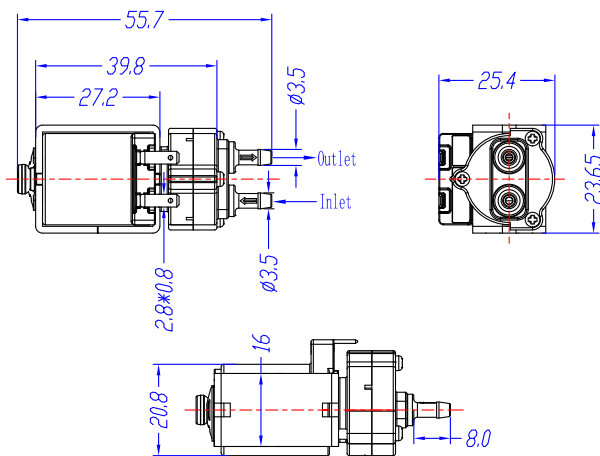

Dimensions/ 单位: millimeters/ 毫米