

DP-2 系列 / DP-2 SERIES



隔膜泵
Diaphragm Pump

PRODUCT INFORMATION/ 产品信息

Pump Design/产品名称: Diaphragm Water Pump/隔膜水泵
 Insulation/绝缘等级: Class A
 Net Weight/产品净重: 0.068Kg
 Outlet Connector/出水接口: Barb port/倒扣 (OD4.8mm/6.5mm)

LABORATORY TEST CONDITION/ 工作条件

- Ta within 60°C, Tf within 35°C / Ta: 60°C以下, Tf: 35°C以下
- ED 100% or work as specified /连续工作或按指定工作方式
- Ta: Ambient temperature / Ta: 环境温度
- Tf: Temperature of fluid water / Tf: 流体温度

APPLICATIONS/ 应用领域

American Coffee Machine、Capsule Coffee Machine、
 Floor Cleaner、Carpet Cleaner、Drinking Water Dispenser
 美式咖啡机、胶囊咖啡机、地板、地毯清洁机、自动饮水机

型号 / Model	DP-2 01	DP-2 02	DP-2 03	DP-2 04	DP-2 05	DP-2 06
流量 / Flowrate (ml/min)	200	350	500	700	900	1100
最大压力 / Max Pressure(bar)	2-4.5	2-4.5	2-4.5	2-4.5	2-4.5	2-4.5
电流 / Current(mA)	<150	<250	<300	<300	<300	<350
噪音 / Noise(dB)	55	55	55	60	60	60
工作方式 / Duty Cycle	ED 100% or work as specified /连续工作或按指定工作方式					
电压规格 / Voltage	DC 3.7-24V					
产品认证 / Product Certificate	RoHS、REACH、FDA					

备注: 上述参数是在DC12V下测得。 / Note: The above parameters are measured under DC12V.

Performance Curve/ 性能曲线

测试条件: 水温20°C, 室温25°C。所有参数公差为 ± 15%, 仅供参考。
 Test Condition: Water temperature 20°C, Indoor temperature 25°C. The tolerance range of all the parameters is ± 15%. Just for reference.

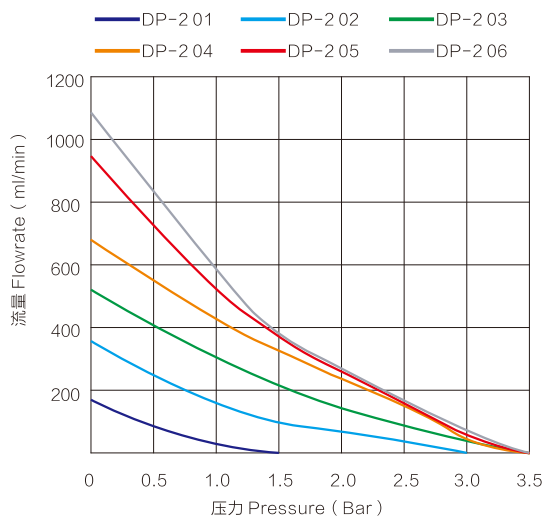

Mechanical Drawing & Dimension/ 外型尺寸

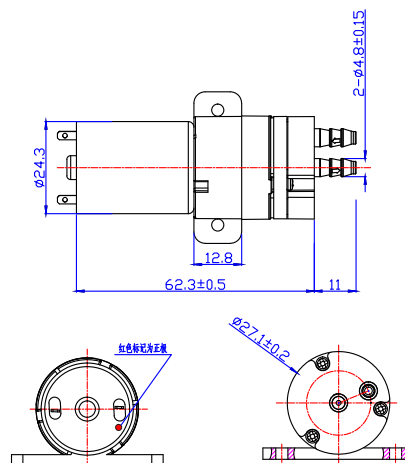

Dimensions/ 单位: millimeters/ 毫米