

# 华星恒泰产品规格书

## PRODUCT SPECIFICATION OF CNHT

型号：PEP-9 系列

Model: PEP-9 Series

### 一、产品信息(Product Information)

产品信息 Product Information			
产品名称 Product Name	蠕动泵 Peristaltic Pump	使用介质 Working Medium	水 Water
绝缘等级 Insulation Class	Class A	流体温度 Fluid Temperature	5-60°C
功率 Power	6W	环境温度 Environmental Temperature	0-50°C
保存条件 Storage Condition	在温度-20~60°C,湿度 65%±15%条件下保存,禁止放置在高温、潮湿及有腐蚀性的环境中。 At the storage condition of temperature -20~60°C, humidness 65%±15%. Do not storage at environment of high temperature, humidity, and corrosive.		



## 二、功能参数(Functional Parameter)

型号 Model	PEP-9
流量 Flowrate (ml/min)	50-450
最低压力 Pressure (bar)	$\geq 1.2$
功率 Power (W)	$< 6$
噪音 Noise (dB)	$< 65$
工作方式 Working Mode	连续工作或按指定工作方式 ED 100% or work as specified
电压规格 Voltage Specification	DC 6-24V
产品认证 Certification of Products	RoHS, FDA, REACH

## 三、产品外形尺寸(Outline Dimension of Product) (mm)

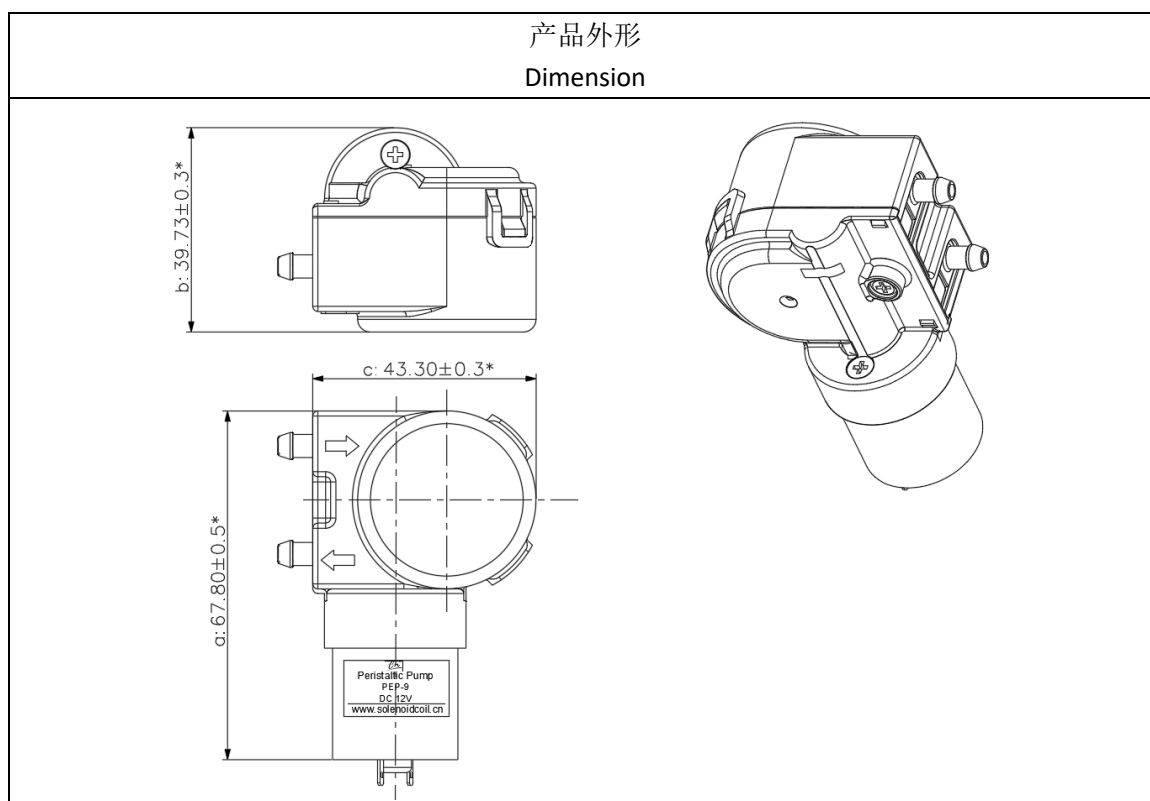

#### 四、性能曲线(Performance Curve)

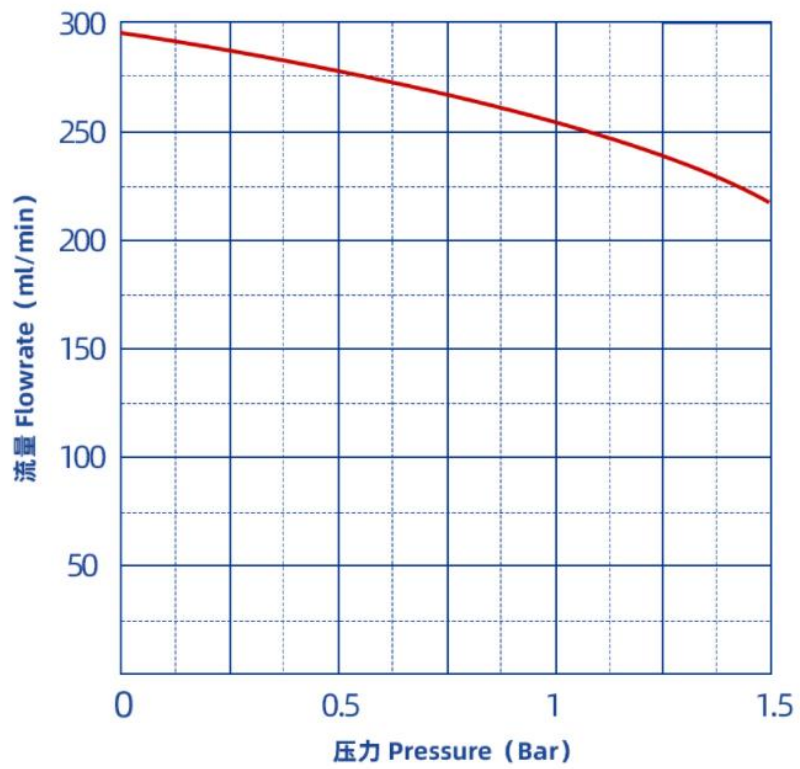

测试条件：周围温度 (20°C±5°C)，相对湿度 (65%±15%)，  
使用流体 (20-25°C的水)，测试电压 (DC 12V)

Test Condition: Ambient temperature (20°C±5°C)，Relative humidity (65%±15%)  
Use Liquid (Water 20-25°C)，text voltage (DC 12V)