



PRODUCT INFORMATION/产品信息

Pump Design/产品名称: Solenoid (Piston) Pump/电磁水泵  
 Insulation /绝缘等级: Class H  
 Net Weight /产品净重: 0.11Kg  
 Outlet Connector/出水接口: Barb port/Thread/倒扣, 螺纹

LABORATORY TEST CONDITION/工作条件

- Ta within 60°C, Tf within 35°C / Ta: 60°C以下, Tf: 35°C以下
- ED 100%: work continuously / ED 100%: 持续工作
- Ta: Ambient temperature / Ta: 环境温度
- Tf: Temperature of fluid water / Tf: 流体温度

APPLICATIONS /应用领域

Steam Station、Steam Mop、Steam Cleaner、Floor Cleaner、Carpet Cleaner、Dehumidifier、Air Conditioning Condensate Discharge、Smoke Machine  
 蒸汽站/台体式蒸汽熨斗、蒸气地拖、蒸气清洁机、地板、地毯清洁机、除湿机、空调冷凝水排放、舞台烟雾设备

Self-priming at 0 BAR (PSI), except SV type Suitable to dry-use only during priming  
 仅无负压下自吸, SV 系列除外, 仅允许在上水启动时短时干抽

型号 / Model	CNS 01	CNS 02	CNS 03	CNS 04	CNS 05
流量 / Flowrate (ml/min)	50	100	150	200	150
最大压力 / Max Pressure (bar)	3.5	3.0	3.0	2.5	2.0
功率 / Power (W)	16	16	16	16	16
噪音 / Noise (dB)	45	45	45	45	45
工作方式 / Duty Cycle	ED 100% or work as specified / 连续工作或按指定工作方式				
电压规格 / Voltage	AC 220-240V/50Hz, 120V/60Hz, 220V/60Hz, 100V/50-60Hz, DC 12-24V/50-60Hz				
产品认证 / Product Certificate	RoHS、REACH、FDA、TUV、UL、CQC				

Performance Curve/性能曲线

测试条件: 水温20°C, 室温25°C。所有参数公差为 ± 15%, 仅供参考。  
 Test Condition: Water temperature 20°C, Indoor temperature 20°C. The tolerance range of all the parameters is ± 15%. Just for reference.

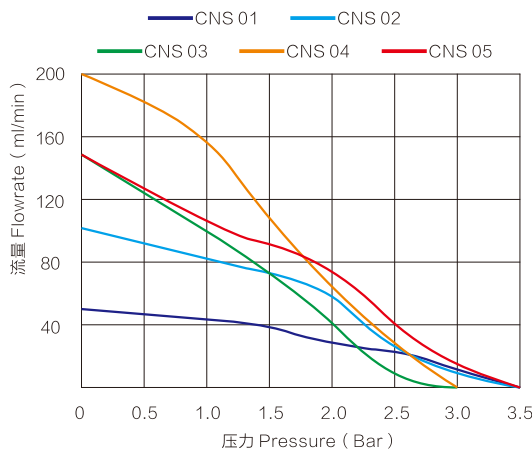

Mechanical Drawing & Dimension/外型尺寸

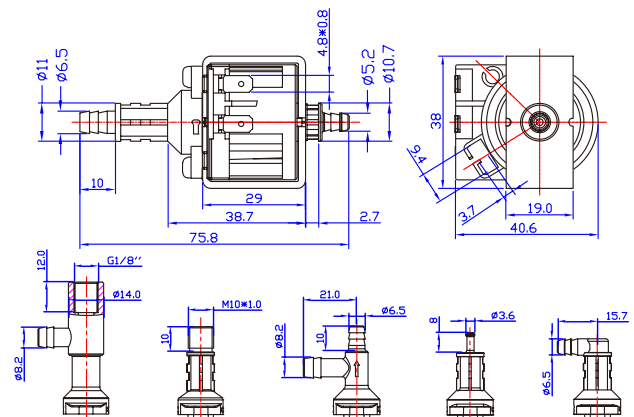

可选出口类型 (Optional outlet type)

Dimensions/单位: millimeters/毫米