

华星恒泰产品规格书

PRODUCT SPECIFICATION OF CNHT

型号：DP-12 系列

Model: DP-12 Series

一、产品信息(Product Information)

产品信息 Product Information			
产品名称 Product Name	隔膜水泵 Diaphragm Water Pump	使用介质 Working Medium	水 Water
绝缘等级 Insulation Class	Class A	流体温度 Fluid Temperature	35°C以下 Below 35°C
电流 Current	≤1000mA	环境温度 Environmental Temperature	0~60°C
保存条件 Storage Condition	在温度-20~60°C, 湿度 65%±15%条件下保存, 禁止放置在高温、潮湿 及有腐蚀性的环境中放置 At the storage condition of temperature -20~60°C, humidity 65%±15%. Do not storage at environment of high temperature, humidity, and corrosive.		



二、功能参数(Functional Parameter)

型号 Model	DP-12
流量 Flowrate (ml/min)	≥ 2000
最大压力 Max Pressure (bar)	2-5
功率 Power (W)	8-12
噪音 Noise (dB)	≤ 65
工作方式 Working Mode	连续工作或按指定工作方式 Work continually or work as specified
电压规格 Voltage Specification	DC 12-24V
产品认证 Certification of Products	RoHS、REACH

三、产品外形尺寸(Outline Dimension of Product) (mm)

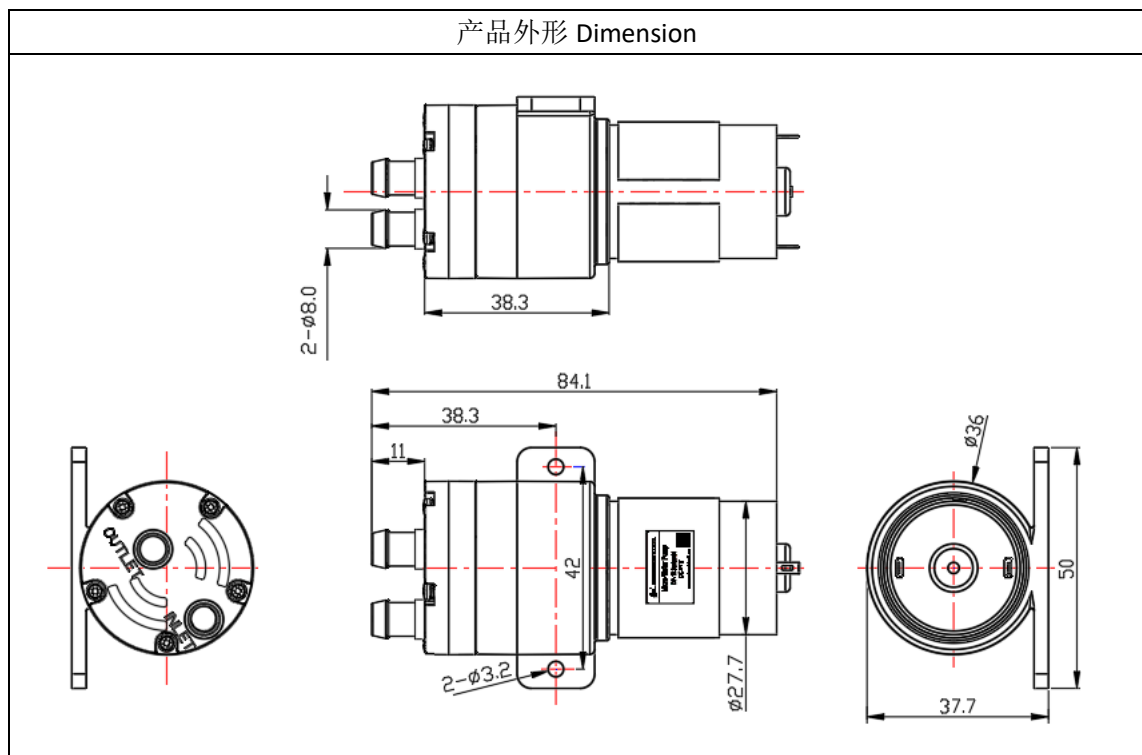

四、性能曲线(Performance Curve)

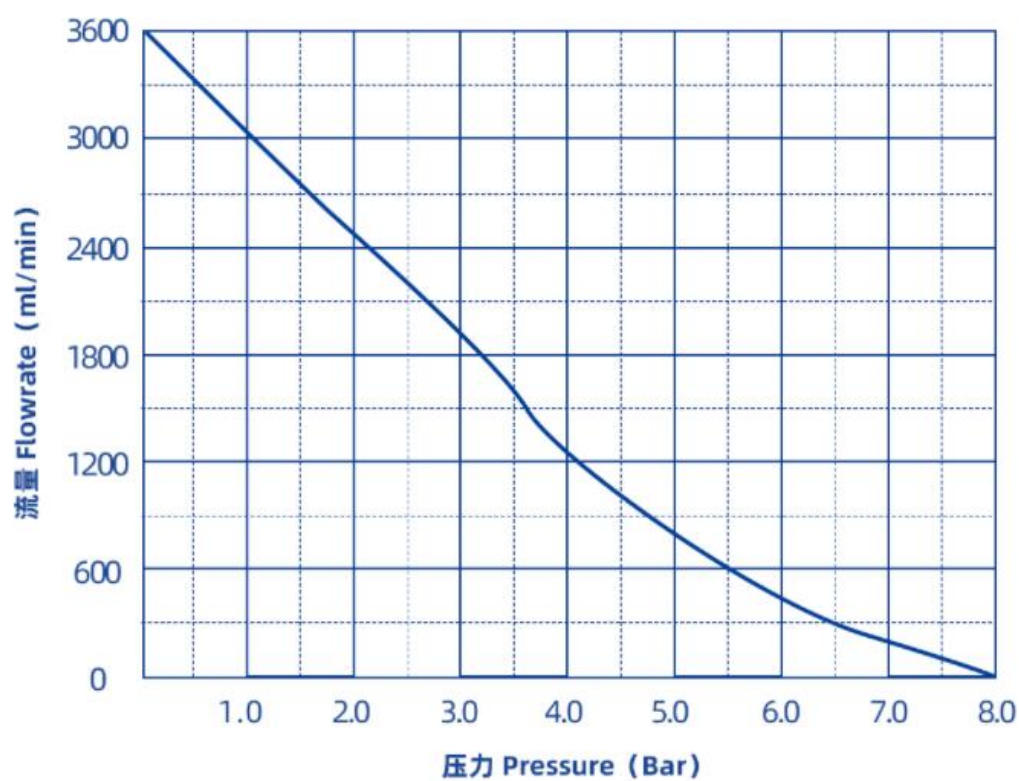

测试条件：水温20°C，室温25°C。所有参数公差为±15%，仅供参考。

Test Condition: Water temperature 20°C, Indoor temperature 25°C. The tolerance range of all the parameters is ±15%. Just for reference.