



UPS
Uninterruptible
Power
Supply

Prostar Industrial UPS

ET-Pro Series Digital UPS
(10kVA-160kVA) 3:3 PF:0.8



LONG
BACKUP



AVR



TEL/MODEM
PORT



SOFTWARES



SURGE
PROTECTION



DIGITAL
DISPLAY



LIGHTNINGPROOF

System Overview



3:3 10kVA~160kVA



DSP Full Digital Control



ECO Mode



Strong Load Adaptability



Human-Machine Interaction



Self-diagnosis Function



Intelligent Battery Management

Features

- ✓ **Power range:10-160KVA**
- ✓ **Flexible application**
- ✓ **Small UPS footprint**
- ✓ **Efficiency up to 93%**
- ✓ **Small impact on power supply**
- ✓ **Multiple communication function**

Prostar has meticulously and independently developed a new generation of ET-Pro series three phases in three phases out UPS. The design adopts advanced DSP digital processor and IGBT Space Vector Pulse Width Modulation (SVPWM), which completely improves the disadvantages of a large number of analog device circuits with low control accuracy and slow control speed in traditional applications. And it can not only effectively solve the drift problem of the analog circuit parameters, but also provide faster, more accurate and stable in system detection and control to comprehensively improve UPS reliability, power supply quality and consistency.

On-line technology fully isolates and protects against all power quality disturbances in even the most demanding environments. Its compact design, high-density technology, N+1 redundancy, and fault-tolerant architecture maximize availability, operational efficiency, and critical load protection, while minimizing total cost of ownership.

High efficiency in double conversion or ECO mode saves valuable energy costs and a comprehensive range of options enables the ET-Pro to be highly effective in any application.

The output electrical performances are fully aligned with today's latest load requirements that include upstream harmonics management for a generator friendly installation and flexible configurations due to the wide range of integrated options and auxiliary equipment. Moreover, due to integration, digitization, intelligent and modularity, it will be next-generation multi-functional online UPS.

Features Introduction

- High-performance DSP full digital control
- Advanced battery management technology (ABM), extending the battery service life according to the charging and discharging characteristics of the battery
- Equipped with combined utility power and battery power supply technology, support utility power and battery power distribution ratio setting, suitable for weak utility grid and large load working environment.
- Great load adaptability for various loads, like motor, impact, inductive, capacitive, non-linear, etc.
- Support 100% unbalanced load, single-phase full load, any two-phase full load.
- With self-detection function to ensure UPS initial start-up safety.
- With fan failure alarm function to notify the users to replace it in time to ensure the reliable operation of the UPS system.
- Unique structure design, full front maintenance, installation against the wall for some models, easy maintenance.
- Support ECO mode, efficiency up to 98% in ECO mode.
- Support parallel function.
- 7-inch LCD capacitive touch screen, providing users with intuitive and convenient operating experience.
- Complete data log for fault record, operation record and status record to be convenient for maintenance.
- Support RS232, RS485, CAN, USB, dry contact, SNMP card, WiFi/GPRS card, etc. to meet various needs.



Performance Characteristics

Full Digital DSP Control

The UPS core system adopts advanced DSP full digital control technology in UPS inverter control, phase synchronization, input rectification control and logic control with high precision, high speed and better performance.

Advanced IGBT Inverter Technology

The combination of high-efficiency and high-reliability IGBT inverter technology and Space Vector Pulse Width Modulation (SVPWM), UPS can reduce system noise and power loss, ensuring that the users can obtain high-quality voltage output and the best economic benefits under various workload conditions. The efficiency of the whole UPS system exceeds 93%.

Human-Machine Interface

The 7-inch color touch screen can provide text and mimic diagrams display at the same time, which is suitable for users to view status, data and operation control. The internal CPU can record historical events and alarm information, and the information storage capacity is up to 10,000.

The display content includes: input voltage, input frequency, output voltage, output current, output frequency, active power, apparent power, load rate, float charge voltage, equalizing charge voltage, charging current, charger temperature, battery voltage, battery pack temperature, remaining battery discharge time, percentage of remaining battery capacity, battery status, historical records, etc.

Intelligent

Advanced digital calibration function, the voltage and current can be calibrated by software without any adjustable resistance.

Self-diagnostic technology, real time monitor the working status of inverter, rectifier and other circuits, detect battery capacity and status, detect UPS working ambient temperature, and detect the failure of each fan to avoid UPS failure.

Low Power Consumption and High Efficiency

Support ECO economic mode operation. When ECO fault, it will transfer to inverter automatically. Allow users to select Online / ECO / Bypass operation modes. In the ECO economic mode, the UPS operating efficiency can be up to more than 98%, which can effectively reduce the UPS system power consumption. And it's the first choice for low-carbon times.

Advance Battery Management

Adopt intelligent advance battery management (ABM) technology to reduce battery maintenance times. The advanced constant current and constant voltage automatic conversion charging technology can activate the battery maximally and save charging time. The battery management system has functions, such as battery capacity prediction, discharge time estimation, and low-voltage warning. Moreover, it can perform self-diagnosis and self-checking for the battery pack, with charging voltage temperature compensation, intelligent adjustment of battery discharge termination voltage, automatic battery discharge activation at regular intervals, automatic setting battery charging current and other functions (this part of the function requires separate configuration components, non-standard), support lithium-ion batteries (requires separate configuration components, non-standard).



Charge Logic

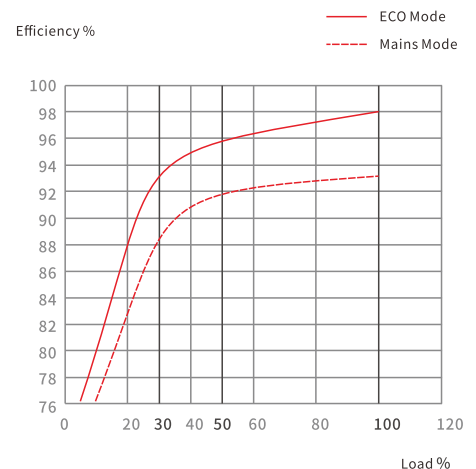
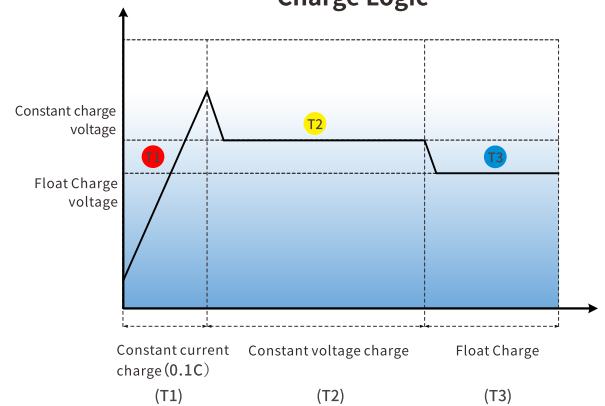

Predictive Alarm System

The LCD panel has automatic detection function, timely forecast and alarm in advance, and self-diagnosis function when UPS initial start-up, which can avoid the risk of failure and personal safety that may be caused by UPS hidden dangers in time.

Support automatic and manual battery online test functions. Users can set different test cycles such as day, week, and month to perform automatic battery test, provide sound and light alarms, and display corresponding information on the LCD display to discover potential battery failures in time.

Powerful Parallel Redundant / Parallel Capacity Function

DSP full digital control technology in the core system, ET-Pro series online UPS has not only N+1 or N+X parallel redundancy, but also increases total power capacity, it can be simultaneously parallel within 8 units, which greatly reduces the user's up-front purchasing costs and subsequent growth costs.

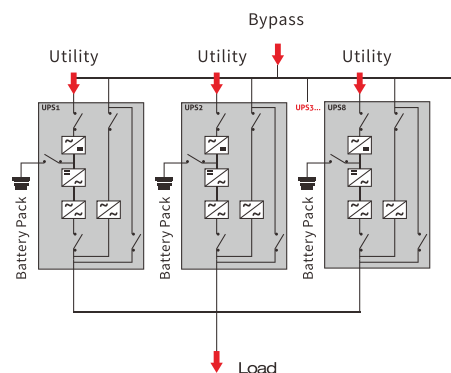

Up to 8 UPS in parallel, each configured with independent bypass

Superior Environmental Adaptability

There is superior environmental adaptability for ET-Pro series Online UPS, and a wide AC input voltage range, thereby reducing battery usage frequency to extend its service life.

Wide AC input frequency range is suitable for connecting various fuel generators.

Three phase output allows 100% unbalanced for 3 phase loads.

Great load adaptability supports RCD non-linear load, industrial grade impact load, motor load, etc.

All circuit boards adopt three-anti-coating technology, that is, dust-proof, anti-humidity, and salt-proof. The UPS can be used in harsh environments, and extend UPS service life.

True Online Double Conversion Technology

True online double conversion technology makes the UPS pure sine output with frequency tracking, phase locking, voltage stabilization, and noise filtering, which is not interfered by electrical grid fluctuations. Output zero transfer time enables UPS to provide more comprehensive protection for users' precision equipment.

ET-Pro UPS is built-in isolation transformer, static bypass switch and manual maintenance bypass switch.

Multiple Communication Interfaces

There are a variety of communication interfaces to monitor the UPS operation status, like RS232, RS485, USB, CAN, NET, Input/Output dry contact, SNMP card, WIFI card, GPRS card and 4G card, etc.

Through external connecting "Prostar IoT" smart cloud box (optional), computer monitoring and mobile APP (including IOS and Android) monitoring can be performed, with remote network management functions. It can also send alarm information via Wechat or mobile text messages to provide real-time UPS data and power information.



PC / Mobile APP Monitoring Interface

Battery Cold Start

In the abnormal state of the utility power, the UPS with a battery cold start switch can be started directly with the battery to meet emergency needs. When the battery is discharged to EOD, UPS only start automatically while the utility is restored, and it has an unattended function.

Integrating Isolation Transformer

ET-PRO series UPS is equipped with an isolation transformer, fully integrated to the UPS unit depending on the customer's galvanic isolation need (output and input). Integrating the transformer directly to the UPS saves footprint and provides all the benefits of galvanic isolation including a very robust buffer between the utility and the critical load.

Comprehensive Protection

The UPS provides perfect software and hardware protection, as well as fan failure alarm. It also provides various protections, like AC input overvoltage/under-voltage protection, AC output overvoltage/under-voltage protection, overload, short-circuit protection, over-temperature protection for inverter and rectifier, battery under-voltage warning and under-voltage protection, battery over-charge protection and other protections to ensure the UPS system operation stability and reliability. Powerful overload ability, it can maintain 60 minutes / 10 minutes / 1 minute under 110% / 125% / 150% overload.

Internal View

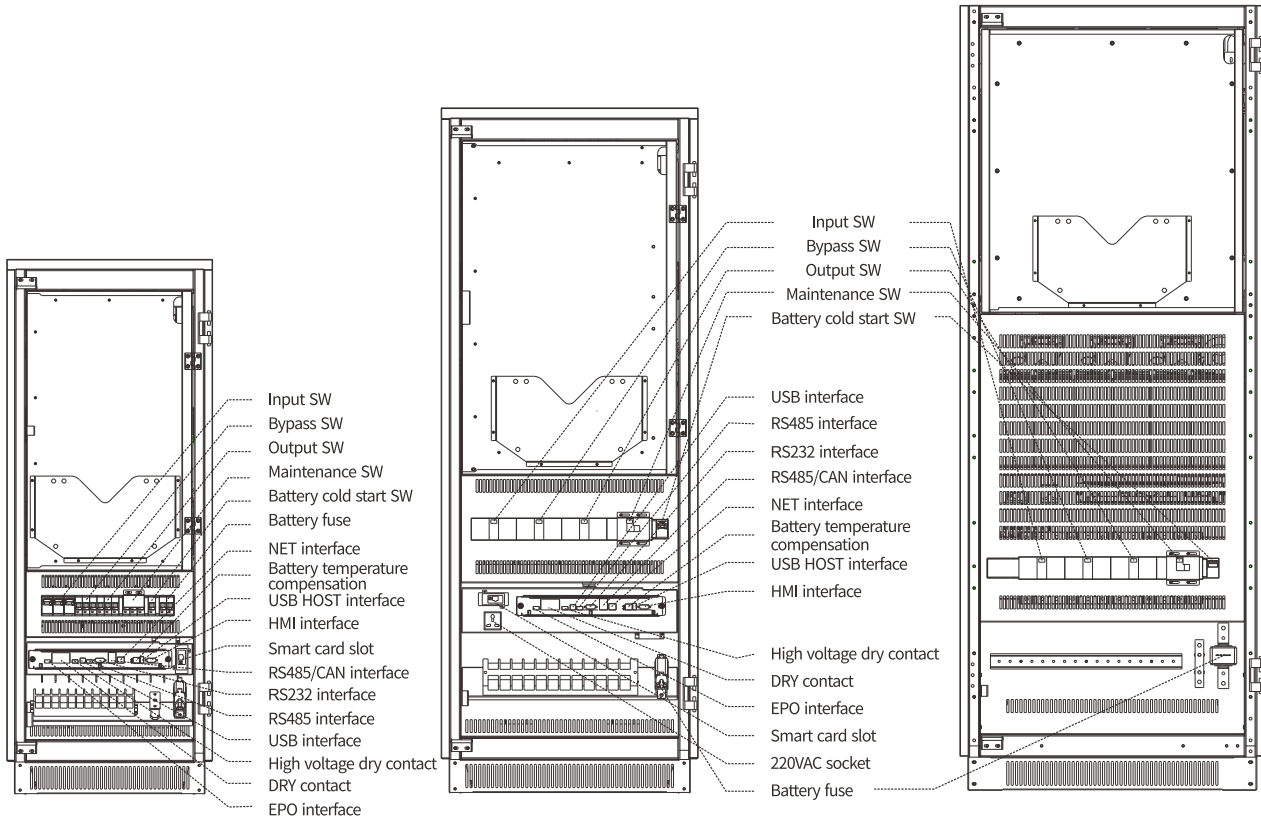

10K~40K

50K~80K

100K~160K

Product Size

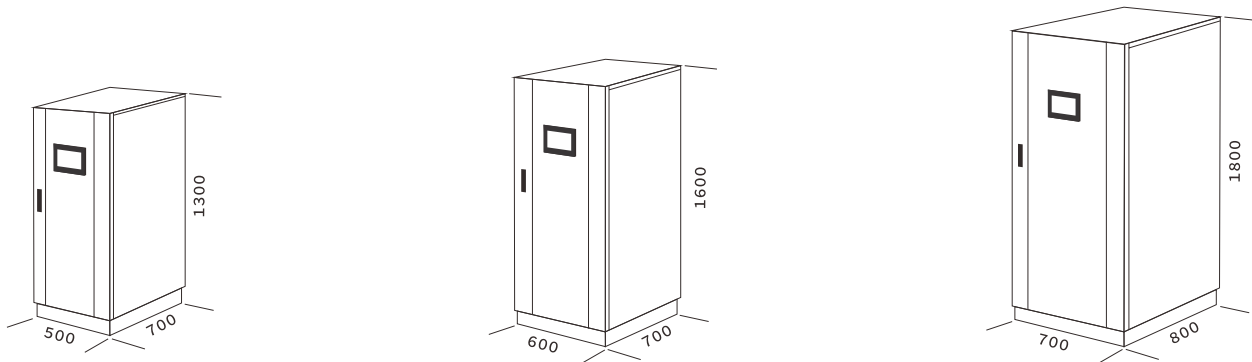

10K~40K

50K~80K

100K~160K

MODEL	ET10K-Pro	ET15K-Pro	ET20K-Pro	ET30K-Pro	ET40K-Pro	ET50K-Pro	ET60K-Pro	ET80K-Pro	ET100K-Pro	ET120K-Pro	ET160K-Pro
Rated Capacity	10kVA/8KW	15kVA/12KW	20kVA/16KW	30kVA/24KW	40kVA/32KW	50kVA/40KW	60kVA/48KW	80kVA/64KW	100kVA/80KW	120kVA/96KW	160kVA/128KW
Size (WxDxH) mm	500×700×1300					600×700×1600			700×800×1800		
Net Weight (KG)	140	150	160	165	200	240	320	440	560	600	650
INPUT											
Input phase	3 phases 5 wires (3Φ+N+PE)										
Input rated voltage	380 VAC /400 VAC /415VAC (Default 380VAC)										
Variable input voltage range	304V-456V										
Input frequency range	40Hz-70Hz										
Input power factor	>0.95										
Input current limit	1.25 times the rated current (0.1-1.25 can be set)										
Rectifier delay start range	Default 10s (1-300 S can be set)										
Bypass input voltage range	Upper limit 10% - 25% can be set, Default 20%; Lower limit 10% - 60% can be set, Default 20%.										
Battery voltage	Default 360VDC (336VDC,348VDC,372VDC,384VDC can be set)										
Number of batteries	Default 12V 30Pcs (28 - 32Pcs can be set)										
Battery charging current	Charging rate * battery capacity * battery pack number (charging rate, battery capacity and battery pack number can be set)										
ECO MODE											
Bypass voltage range	Upper limit 5% - 15% can be set, Default 5%; Lower limit 5% - 15% can be set, Default 5%.										
Bypass frequency range	± 1Hz - ±3Hz can be set, Default ±2Hz										
OUTPUT											
Output phase	3 phases 5 wires (3Φ+N+PE)										
Rated output voltage	380 VAC /400 VAC /415VAC (Default 380VAC)										
Output voltage regulation	±1%										
Output voltage trimming	0V (±1-±5V can be set)										
Output frequency accuracy	Mains mode: tracking bypass input in synchronization state; battery mode: 50Hz/60Hz±0.1%										
Output power factor	0.8										
Output waveform distortion	≤2% (Linear load); ≤5% (non-linear load)										
Waveform	Pure sine wave										
Output current crest factor	3:1										
Inverter overload capacity	When the load is <105%, it can work for a long time; when 105%<load<110%, it will switch to bypass output after 60 minutes; when 110%<load<125%, switch to bypass output after 10 minutes; when 125% <load< 150%, switch to bypass output after 1 minute; when load> 150%, switch to bypass output after 200 milliseconds;										
SYSTEM											
System efficiency	Online mode: >93%, ECO mode: >98%										
Transfer time	0ms										
Number of parallel	≤ 8 sets										
Protective function	Output short circuit protection, output overload protection, over temperature protection, battery low voltage protection, output over and under voltage protection, fan failure protection, etc.										
Communication Interface	Standard USB, CAN, EPO, RS232, RS485, dry contact; Optional SNMP card, temperature compensation accessories										
Display	7 inch LCD touch screen										
ENVIRONMENT											
Operating temperature	0-40°C										
Storage temperature	-25°C-55°C (exclude battery)										
Relative humidity	0%-95% (No condensation)										
Altitude	Altitude ≤1000M,Capacity de-rates by 1% for every 100m over 1000m										
Degree of protection	IP30										
Noise	<65dB (1 meter from the device)										

● Remarks:Products specifications are subject to change without notice.

Guangdong Prostar New Energy Technology Co., Ltd.

[Http://www.Prostarpower.com](http://www.Prostarpower.com)

Website

