



# Precision I

---

## Instruction Manual

### Model Horse Flame HF905-SE Precision I Smoke Exempted Free-standing Multi Fuel Non-Boiler Stove

*Published June 2011*

**Please note** This appliance has been independently tested and approved by DEFRA as an 'exempted appliance' to allow the burning of wood in designated UK Smoke Control Areas (see *page 10*). It must, at all times, be operated in accordance with the instructions to minimise the amount of smoke produced.

You will need to refer to the serial number of your stove shown above should you ever need to make a claim under the Horse Flame Warranty. You will also find the serial number, beginning with HF, on the CE plate at the rear of the stove as well as on the lid of the outer packaging.

Write the date the stove was delivered to you below as this is likely to differ from the purchase date.

 -  - 

[www.hi-flame.com](http://www.hi-flame.com)

Ref: HF905-SE / UK-NI-ROI / V3.01-06-11

## CONTENTS

	<b>Page</b>
Packing List	2
Standard Features	3
Dimensions	4
Technical Data	5
Introduction	6
Important Safety Advice	6
Assembling the Stove	7
Installation Regulations	9
Smoke Control Areas	10
Recommended Fuels	10
Prohibited Fuels	11
Important: First Fires	12
Understanding Fuel Types	13
Burning Wood Logs	13
Burning Multi Fuels	17
Some Simple Tips	18
Removing Ash	19
Installation Check-list	20
Installation General Guidelines	21
Commissioning	25
Trouble-shooting	25
Routine Checks	30
Standing Down	30
Routine Maintenance	31
Horse Flame® Warranty	33
Annual Service	34
Service Record	35
Spares Service	Back Cover

## PACKING LIST

As soon as you receive your new stove please check that you have a full set of components as set out in the list below. In the unlikely event of a shortage, please report this immediately to the dealer you bought the stove from. Never attempt to operate the stove with missing or damaged components.

### **Product Information**

- 1 Instruction Booklet
- 1 Warranty Card

### **Stove Components**

- 1 Stove Lid
- 1 Handle Cover
- 1 Handle Cover Securing Bolt
- 1 Log Retaining Bar

### **Equipment**

- 1 Ashpan
- 1 Operating Tool

### **Tool Bag**

- 1 Safety Mitten
- 2 Spare Glass Retaining Clips
- 2 Spare Glass Retaining Clip Screws
- 1 Spare Rope Seal (for door)
- 1 Allen key (for door hinges)



## STANDARD FEATURES

**1 Primary Air Control** Air which enters under the grate for burning multi fuels, (other than wood). Also used at the beginning of wood fires

**2 Pre-heated Secondary Air Control** Air enters at the base of the stove is pre-heated to ensure the fire-chamber is not cooled down by new colder air. This ensures a higher fire-chamber temperature and therefore a cleaner, more efficient burn. Controls the air supply when burning wood

**3 Pre-heated Tertiary Air System** Pre-heated air enters the stove through jets in the special cast iron heat sink at the rear of the firechamber. This ensures a much longer, cleaner burn from the Precision I even in the latter stages of fire cycle

**4 Airwash System** Part of the secondary air control system which diverts pre-heated air down along the front of the glass to burn off unwanted dry sooty particulates and help keep it clean

**5 Top or Rear Flue Option** Simple to switch depending on the type of installation

## IMPORTANT

In the interests of safety please read these instructions carefully before installing or operating your new stove. Even if you have installed or operated stoves before, manufacturer's requirements can vary and can also change with updates to building regulations. If installed in a UK Smoke Control Area this stove must be operated in accordance with the instructions to minimise the amount of smoke produced.



## DIMENSIONS

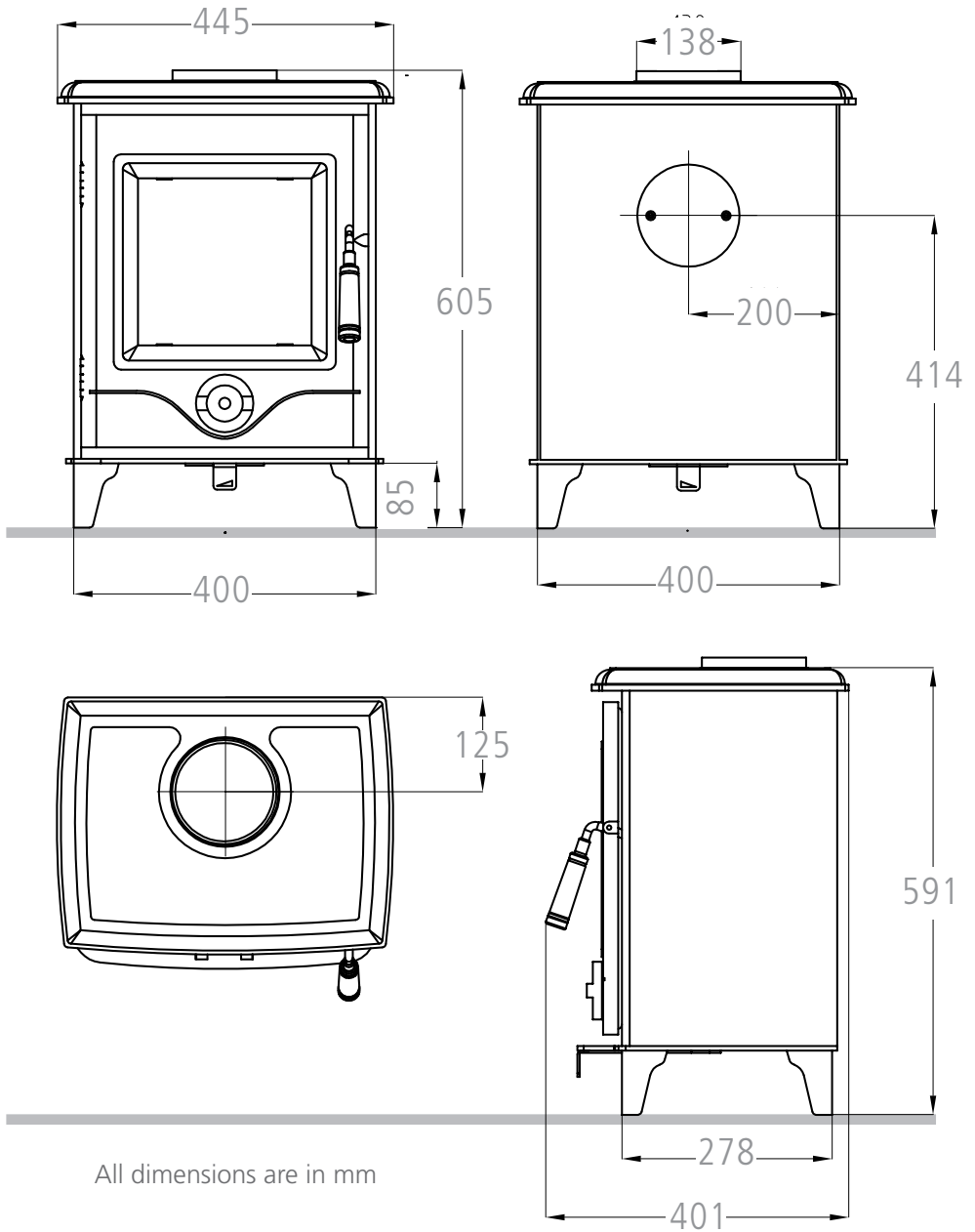

## TECHNICAL DATA

### General Specification

Model Name	<b>Precision I</b>
Model Number	<b>HF905-SE</b>
Overall Height	<b>605 mm</b>
Overall Width	<b>445 mm</b>
Overall Depth	<b>401 mm</b>
Net Weight	<b>79 kg</b>
Gross Weight (packed)	<b>90 kg</b>

### Data from CE Test EN13240

#### Wood Logs:

Nominal Heat Output	<b>4.9 kW</b>
Refuelling Interval	<b>51 minutes</b>
Efficiency (net)	<b>84.3%</b>
Mean CO Emission (at 13%)	<b>0.38</b>
Mean Flue Gas Temperature	<b>208°C</b>
Flue Gas Mass Flow	<b>3.3 g/s</b>

#### Smokeless Fuel (Ancit):

Nominal Heat Output	<b>4.9 kW</b>
Refuelling Interval	<b>60 minutes</b>
Efficiency (net)	<b>71.4%</b>
Mean CO Emission (at 13%)	<b>0.13</b>
Mean Flue Gas Temperature	<b>311°C</b>
Flue Gas Mass Flow	<b>3.7 g/s</b>

### Minimum Distance to Combustibles

Rear	<b>900 mm</b>
Sides	<b>700 mm</b>

### Fuel Requirements

#### Wood Logs:

Moisture content	<b>&lt;20%</b>
Maximum Log Length	<b>300 mm</b>
Maximum Fuel Load	<b>1.5 kg</b>

#### Multi Fuel:

Hetas Approved Manufactured Smokeless Fuels See <a href="http://www.hetas.co.uk">www.hetas.co.uk</a>	
Maximum Fuel Load	<b>1.5 kg</b>

### Flue

Flue configuration	<b>top or rear</b>
Flue pipe diameter	<b>125 mm</b>
Height to centre of rear flue	<b>414 mm</b>
From centre of top flue to back	<b>125 mm</b>
Minimum flue height from base of stove	<b>4500 mm</b>

## INTRODUCTION

**Thank-you for purchasing the Horse Flame® Precision I stove. We are confident that with its state-of-the-art combustion technology it will warm your home even on the coldest winter days and provide you with many years of pleasure.**

**Before you install or operate your stove however, please read this booklet which contains important safety advice as well as instructions which will help you make the most of your new stove.**

**All users of this stove should be aware of the contents of this handbook. If other people are going to operate the stove then please keep this booklet handy so that it can always be quickly referred to.**

**Never let anyone use the stove who is unfamiliar with its correct operation.**

## IMPORTANT SAFETY ADVICE

- Ensure that an approved carbon monoxide detector (BS EN50291:2001) is fitted in the same room as the stove. It should be powered by a battery designed for the working life of the alarm. *Please note* that since October 2010 this is now a requirement under UK Building Regulations.
- External surfaces including the fire-chamber door and operating handles, windows, flue pipes and stove bodywork will become extremely hot. Always use the tool provided and avoid touching these parts of the stove without proper protection, such as heat resistant gloves or other protective aids.
- Potentially combustible material or objects such as soft furnishings should never be left on or near any of the stove's hot surfaces. Ensure that wood supplies and log baskets are kept at a safe distance from the stove.
- Never leave children unattended in the room where your stove is being operated. Ensure that children are aware of the potential danger and make sure that they keep clear of the stove when it is in operation. Where children, the elderly or the infirm are present always use an approved safety fireguard (BS6539) to prevent accidental contact with the stove.
- This stove should *not* be fitted in a room with an extractor fan (eg kitchen) as this will adversely effect the air quality in the room and could be dangerous for the room's occupants. It will also starve the stove of combustion air and reduce the stove's efficiency.

- To ensure your safety make sure that your stove's installation complies with all local building regulations' ventilation requirements. Low energy houses have their own particular requirements and should be strictly adhered to.

- Do not use flammable liquids to ignite the fire. In the confined space of the firechamber there is a real potential to cause a life-threatening flash flame or explosion.

- Never over-fire the stove. If any external parts of your stove glow red during operation then immediate action should be taken to reduce the supply of air to the firechamber through the Primary and Secondary air controls which should quickly limit the intensity of the fire.

- This stove is CE approved and tested to EU EN13240 standards in the United Kingdom by Gastech at CRE of Stoke Orchard, Gloucestershire. Alterations to its construction could be potentially dangerous and will render your product warranty void.

- Do not use aerosol products in the vicinity of the stove when it is in use.

- Check and clean the stove's flue way and the top of baffle plate regularly to help avoid potential blockages (see *page 31*).

- Clean your chimney regularly (see *page 31*).

## ASSEMBLING THE STOVE

Your new Precision stove is extremely heavy. Always handle with care and make sure that you have additional strong help when you move it.

The ash lip on the Precision I is factory fitted and, along with the door and door handle, should not be used to grip the stove as they could be damaged from supporting the stove's weight. Items, such as the lid and fuel retaining bar, can be removed to help reduce the weight. Under no circumstances should the door be removed as this will invalidate your Horse Flame® Warranty.

- **Unpack** Remove your new stove from its recyclable packaging. Retain this until the stove is installed and is fully operational. Unfasten retaining wires and remove any components, including those inside the ash pan, from inside the stove

- **Inspect** Please inspect the stove to check that it has not been damaged in transit – never attempt to install a stove which has been damaged. If damage is suspected then report this immediately to your stove dealer

- **Check List** Study the component check list on page 2 and make sure that you have all of the components listed before proceeding. Some components are contained within the ash pan

- **Baffle Plate** Check the position of the baffle plate (sometimes known as the throat plate) inside the 'roof' of the stove to ensure that it has not moved during transit. This is a heavy metal plate which directs flames and helps

retain heat inside the stove. The base of this plate should sit securely on a small ledge at the back of the firechamber, towards the top. The rest of the plate sits on top of the side firebricks to maintain it at the correct angle and in line with the top of these side firebricks. It is best to fully familiarise yourself with the baffle plate's correct location by practising removing it and re-fitting it prior to the stove's installation as you will need to regularly check the top of this plate and the access to the flue way to avoid potential soot build up and blockages. Once you know how to do this it is a very easy operation.

See page 31

• **Flue Options** The HF905-SE stove is delivered already configured for a top fitted 125mm (5") flue pipe but can easily be switched to the rear fitting flue option. To do this, remove the 'hob' from the rear flue aperture by unscrewing the two bolts. Always use the correct sized Phillips crosshead screwdriver and be careful not to damage the bolt heads as these will be re-used. In the same way, remove the flue collar on the lid. Swop the sealing plate and flue collar over. The cover and sealing gasket can now be re-used as a blanking plate to seal the top flue aperture. Re-attach the flue collar and gasket to the rear, again being careful not to damage the bolts.

Ensure that the rope gasket is positioned correctly to make a good all-round seal between the collar and plate. Lubricate the new bolt holes with machine oil to avoid damaging the screw threads. Heat-resistant cement

may also be required to ensure an adequate seal between the stove and components.

• **Handle Assembly** Thread the split washer along the handle bolt. Feed the bolt and washer through the handle grip. Use a Phillips crosshead screwdriver to attach the assembled grip to the door handle clamp mechanism on the door, being careful not to over-tighten.

Your stove is now ready for installation.

• **Moving** Do not drag the stove. Always lift the stove to finally position it. Alternatively it may be possible to place the stove on heavy duty plastic sheeting or thick floor covering to slide the stove into position, being careful not to damage any finished floor surfaces with trapped grit or building debris.



## **INSTALLATION REGULATIONS**

*You must ensure that your stove is installed by a recognised competent person who is appropriately qualified in the installation of stoves and that the installation complies with all local, national and European building regulations.*

In the UK we strongly recommend using a Hetas registered installer ([www.hetas.co.uk](http://www.hetas.co.uk)) and in Ireland a registered installer from INFO – the Irish Nationwide Fireplace Organisation ([www.fireplace.ie](http://www.fireplace.ie)). Your authorised Horse Flame® dealer will also be able to help and advise you.

For further information on local Building Regulations please consult:

### **England & Wales**

Building Regulations Document J (revised October 2010) – Combustion Appliances and Fuel Storage Systems  
[www.planningportal.gov.uk](http://www.planningportal.gov.uk)

### **Scotland**

Building Standards (2001) Domestic  
[www.sbsa.gov.uk](http://www.sbsa.gov.uk)

### **Northern Ireland**

The Building Regulations (Northern Ireland) 2000 / Amendment 2006 / Amendment No 2 2006  
[www.buildingcontrol-ni.com](http://www.buildingcontrol-ni.com)

### **Isle of Man**

Building Regulations (2007) – Isle of Man  
[www.gov.im](http://www.gov.im)

### **Republic of Ireland**

Approved Document J – Heat Producing Appliances  
[www.environ.ie](http://www.environ.ie)

### **Other Information Points**

For additional useful information and links to the government websites above, including informative downloads, visit The Solid Fuel Technology Institute website [www.soliftec.com](http://www.soliftec.com).

The Solid Fuel Association website is also a very good source of practical information and downloads  
[www.solidfuel.co.uk](http://www.solidfuel.co.uk).

The British Flue and Chimney Manufacturers Association website, accessed through [www.feta.co.uk/bfcma](http://www.feta.co.uk/bfcma), produces an authoritative and informative download *Yellow Guide* to solid fuel flues and chimneys.

### **Buildings Insurance**

It is a requirement by some building insurance companies to inform them of the installation of a new fixed heating appliance and a relevant certificate of compliance produced.

### **Health & Safety**

During the installation of this stove and any related building works you must comply with any current Health & Safety at Work regulations.

## SMOKE CONTROL AREAS

### The Clean Air Act 1993 and Smoke Control Areas

Under the Clean Air Act local authorities may declare the whole or part of the district of the authority to be a Smoke Control Area. It is an offence to emit smoke from a chimney of a building, from a furnace or from any fixed boiler if located in a designated Smoke Control Area. It is also an offence to acquire an 'unauthorised fuel' for use within a Smoke Control Area unless it is used in an 'exempt' appliance ('exempted' from the controls which generally apply in the Smoke Control Area).

The Secretary of State for Environment, Food and Rural Affairs has powers under the Act to authorise smokeless fuels or exempt appliances for use in Smoke Control Areas in England. In Scotland and Wales this power rests with Ministers in the devolved administrations for those countries. Separate legislation, the Clean Air (Northern Ireland) Order 1981, applies in Northern Ireland. Therefore it is a requirement that fuels burnt or obtained for use in smoke control areas have been 'authorised' in Regulations and that appliances used to burn solid fuel in those areas (other than 'authorised' fuels) have been exempted by an Order made and signed by the Secretary of State or Minister in the devolved administrations.

Further information on the requirements of the Clean Air Act can be found here:

[www.smokecontrol.defra.gov.uk](http://www.smokecontrol.defra.gov.uk).

Your local authority is responsible for implementing the Clean Air Act 1993 including designation and supervision of Smoke Control Areas and you can contact them for details of Clean Air Act requirements.

### RECOMMENDED FUELS

The Precision I HF905-SE stove is approved by DEFRA as an 'exempted appliance' to allow the burning of wood in designated UK Smoke Control Areas. It must, at all times, be operated in accordance with the instructions to minimise the amount of smoke produced.

The following fuels are approved by Horse Flame® for use in the HF905-SE:

- **Wood Logs** *Only ever use dried, fully seasoned chopped wood logs with a moisture content of less than 20%.*

Wood which is well seasoned makes a distinctive 'clack' rather than a dull 'thud' when knocked together. It will also feel much lighter than an unseasoned log. Other indicators include bark peeling away and cracking and splitting around the outside.

Ideally wood should be seasoned outdoors for between 18 to 24 months – the harder the wood then the longer the seasoning. It should be stacked off the ground with plenty of space between the logs to allow air movement and with the top covered to keep rain and snow out. Seasoned wood will give you approximately 50% more heat output than the equivalent unseasoned log.

Most types of hardwood, for instance Ash (generally regarded as the best), Birch, Beech, Oak and Elm can be used. However, avoid woods with a high resin content. As a rule of thumb, the heavier the wood, then the greater the heat output and the longer burn time – the time between refills. All of this is providing it is fully seasoned wood.

*Never use wet or unseasoned (green) wood as this will cause nuisance smoke and a very disappointing fire.*

It could quickly result in the build up of soot and creosote which, because of the higher temperatures of stove flue gases, could easily cause a flue or chimney fire. In addition, burning wet wood creates other environmental problems, a less efficient fuel economy and can eventually clog your flue system and cowl. It will also reduce the effectiveness of the stove's Airwash system thus causing staining and blackening of the glass.

Wet or unseasoned wood produces the following poor performance:

- Hard to light fires
- Fires that are difficult to keep going or to keep burning well
- Smoky fires with fewer flames which are also of a dull orange colour
- Increased dense grey / blue smoke from the chimney
- Shorter burn times
- Low heat output
- Dirty glass and firebricks
- Excessive and rapid creosote build-up in the flue system and chimney
- Unpleasant smoky smells both inside and sometimes outside the house

Manufactured or finished wood products, such as plywood and chipboard, must also be strictly avoided because of the high chemical adhesive content used in their production which will also leave harmful residue inside the stove and flue system.

For more information about wood fuel visit the DEFRA funded National Energy Foundation website *Logpile* at [www.nef.org.uk/logpile](http://www.nef.org.uk/logpile).

• **Peat or Turf** *Do not use in a Smoke Control Area.* Peat is an excellent cost-effective fuel alternative and provides a similar calorific heat output to wood but has a higher ash content so that you will be required to empty the ash pan more often. It's also clean and easy to handle with low atmospheric emissions.

• **Multi Fuels** (Other than wood or peat). *Only burn Approved Smokeless Fuels in a Smoke Control Area.* Use solid fuels which are recommended and approved for use in stoves.

If you cannot burn wood then we always recommend burning a smokeless alternative as this is better for the stove and flue system as well as the environment. There are many different brands of high quality smokeless coal nuggets available in the UK and your local fuel merchant, preferably a member of the Approved Coal Merchants Scheme, will be able to advise you on those suitable for multi fuel stoves. You can also find out more about the various fuel types by visiting [www.hetas.co.uk](http://www.hetas.co.uk) and [www.solidfuel.co.uk](http://www.solidfuel.co.uk).

## PROHIBITED FUELS

*Never use your stove like an incinerator.* Burning prohibited 'fuels' is an offence in a Smoke Control Area and could create nuisance smoke which is also an offence in non-Smoke Control Areas. Burning the following 'illegal' materials could also damage your stove and flue system, as well as render the product warranties on the stove and flue system components void.

- **Petroleum Coke** Never burn petroleum coke as this burns at a very high temperature and its continued use will almost certainly cause irreparable damage to components such as the grate, baffle plate and fire bars.
- **Bituminous House Coal** is not recommended because it produces excessive soot deposits, which is not good for the environment, and also considerably increases the need for cleaning the stove and flue system.
- **Household Rubbish** Printed matter (excluding very small amounts of newspaper for starting the fire), plastic, rubber, lacquered or impregnated wood, plywood, chipboard and household rubbish, such as milk cartons, should also be avoided. During combustion some of these materials may develop substances which could be hazardous to your health and be harmful to the environment.
- **Flammable Liquids** Never use methylated spirits, petrol or other highly inflammable liquids for lighting the fire as these could cause an explosion in the confined spaces of the firechamber.

## IMPORTANT: FIRST FIRES

Use smaller and shorter 'gentle' fires the first five or six times that you fire up the stove, making these progressively bigger, as this will avoid any potential thermal shock and allow the cast iron components to 'acclimatise' with each other. Allow the stove to fully cool down between these fires.

When first using the stove it is normal to experience paint fumes or see light smoke rising from some of the stove's painted surfaces. During this stage ensure that the room has additional ventilation by opening doors and windows to minimise any adverse effects.

The hotter you burn the stove the more intense these fumes will be, which is one of the reasons that we advise that you use smaller fires to start with. Every time the stove reaches a new higher temperature it may still be possible to smell these fumes or see some gentle smoke until the paint work is fully cured.

If smoke and fumes persist do not use the stove and immediately consult your installer, as this may indicate that there could be a possible problem with the installation.

## UNDERSTANDING HOW DIFFERENT FUELS BURN

Wood and solid fuels (multi fuels) burn in different ways and you will need to understand these differences if you want to get the best out of operating your stove.

Basically solid fuels need a flow of combustion air through the bottom grate whereas wood does not require this as its combustion air can be taken from above the grate. Wood always burns best on a bed of its own embers and shouldn't need to be riddled. On the other hand, solid fuel requires riddling to maintain an adequate air flow from underneath the grate.

Your new stove can burn very well, or very poorly, depending on how you light the fire, how you refuel the fire, and, of course, the type and quality of the fuel that you are burning. A flue temperature gauge and log moisture meter are both cost-effective investments and are highly recommended if you want to maximise the efficiency of your stove and fuel.

Wear protective gloves when loading a burning stove and place logs and other fuels precisely where you want them by using heat-resistant tongs. Always open the stove door gently to avoid unnecessary air turbulence which could cause ash or small lighted embers to be drawn from the fire chamber and beyond the protective hearth. Never operate the stove without the fire fence (or log guard) in position.

*The stove is not designed to be operated with the door open.*

## BURNING WOOD LOGS

As previously stated wood burns best on a bed of its own embers which also forms a barrier that reflects heat and protects the fire grate from being damaged. You can therefore leave a bed of ash in place to create a layer of approximately 25mm (1"), only occasionally removing the surplus ash.

The end grain of the wood produces more of the remaining moisture and gases so whenever possible point the log ends away from the glass to help keep the glass clean.

**Fuel Load** Ideally the logs should be approximately 225 – 250mm (9" – 10") long and a typical fuel load should weigh 1.0 – 1.5kg (2.2lb – 3.3lb).

To get the best out of your stove, ideally you will need three different thicknesses of wood log as you build the fire through each lighting phase:

**1 Kindling** This is generally finely chopped wood, approximately 5 to 10mm thick (1/4" to 1/2") from your supply of logs. Alternatively use dried twigs or small branches which have also been fully seasoned

**2 Lighting Logs** These are slightly bigger diameter logs, approximately 25 to 50mm (1" to 2")

**3 Refuelling Logs** These should be approximately 75 to 100mm thick (3" to 4"). Bigger logs should be split down to this size

### Lighting a Wood Fire

The main difference between smoke and flame is temperature, so when

lighting a fire you need to get the temperature in the firechamber as high as possible as quickly as possible. This is also critical in creating a good 'draw' within the flue system, especially when it is particularly cold outside.

When flue gas temperatures are below 120°C, creosote tars form within the gases and the fire will be smoky and burn with a dull orange flame. Burning the stove like this for a sustained period will create unnecessary smoke and not be good for the chimney or flue system.

### **1 The Lighting Phase**

For best results:

*Primary Air – fully open*

*Secondary Air – fully open*

*Door – slightly ajar (optional)*

Avoid trying to light the fire with excessive amounts of paper as this has a very high ash content which can 'smother' the ash bed. If you have good dry kindling or sticks then paper should not be needed at all.

The size of the logs used at each stage is also important. If the kindling wood is too large this will not light well and will be slow to get started. Two handfuls of smaller pieces of kindling (equivalent to the weight of typical log) layered in a criss-cross or 'wig-wam' and a small firelighter will get the fire well established and up to operating temperature quickly.

If you feel you have a weak chimney draught, then keeping the stove door slightly ajar for the first 10 – 15 minutes will assist, after which it should be closed. This will also help prevent the build-up of condensation on the door

glass until the glass warms up, especially if you have not used the stove for a few days.

During the lighting phase the Primary and Secondary air settings on the stove should be fully open.

### **2 The First Refuel Phase**

For best results:

*After 10 minutes*

*Primary Air – close completely*

*Secondary Air – fully open*

*Door – closed*

Once the embers are starting to glow and the flames start to calm down the first refuelling can take place. For this stage use slightly larger pieces of wood than the lighting wood – but smaller than the main refuelling wood in the next phase. The reason for this is that the embers from the kindling wood are small and will not hold a high temperature for too long.

If unnecessarily large pieces of wood are placed on the embers at this stage and do not ignite well there is a risk that the firebox will cool down and the wood start to smoke. When the first refuelling wood is burning well (say, after about 10 minutes from the start) the Primary air can be completely shut off.

### **3 The Main Firing Phase**

For best results:

*After 17 or 18 minutes –*

*Secondary Air – adjust to suit*

*Primary Air – remains closed*

*Door – remains closed*

Once the embers of the first refuel phase are glowing then these can be

evenly spread with a poker or companion tool and the main refuelling wood can be quickly set.

Wood burns best if the flames have other wood to 'play off'. For example a single dense piece of wood or log will not burn as well as 2 or 3 smaller logs of equivalent mass. The more contact the wood has with each other piece, the hotter the embers will be. 3 or 4 logs tightly packed to each other will burn longer but at a lower temperature than loosely criss-crossed logs.

Approximately 1.0 to 1.5kg of wood logs can be added at this stage. Be careful not to add too many logs as they may 'smother' the fire.



*The recommended maximum fuel load: Photo shows a typical loosely stacked fuel load of approximately 1.5kg of fully seasoned wood logs approx 250mm (9") long by 75 – 100mm thick*

Try to avoid setting the ends of the logs pointing towards the glass as this can cause staining which the Airwash may find difficult to remove.

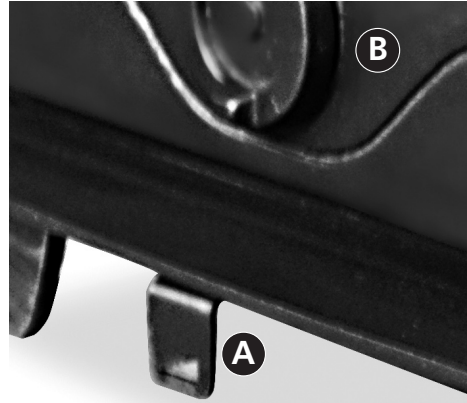

*Use the tool provided to adjust the Secondary air / Airwash control A at the base of the stove – moving it to the left hand side will reduce the air supply and 'slow' the fire down. B is Primary air*

Only reduce the Secondary air control when the wood has 'carbonised' and the fire is burning at a high temperature. This is when the ash on the burning wood looks light grey and virtually covers all of the wood. A flue temperature gauge will be invaluable.

You will be able to tell when the stove is at this stage by studying the colour of the burning surfaces – the 'lighter' they are the better the wood is burning. If the log surface is predominately black and / or the flames are a dull orange then there is still some time to go before the fire is operating at full temperature.

Never leave the stove unattended after refuelling until the flames are well established on the new logs. Always load onto a bed of hot embers.

Once the fire is established the flame pattern can then be adjusted to your

requirements with the Secondary air (Airwash) control.

Getting the balance right between a gently burning stove and one that is burning too slow, creating smoke and causing the Airwash to fail and consequently the glass to stain is very much a matter of trial and error. If you are burning well-seasoned wood then a quick 'blast' of the stove operating at 'full throttle', with Secondary and Primary air fully open, should quickly burn off any deposits left from any slower burning phase.

#### 4 Refuelling

For best results: *Just before you refuel –*  
*Primary Air – fully open*  
*Secondary Air – fully open*

*After loading and when new fuel is burning well –*

*Primary Air – close completely*  
*Secondary Air – adjust to suit*

Regular, smaller loads are better because they keep the firechamber at a higher temperature, without over-firing it. The higher operating temperature helps prevent nuisance smoke and sooty deposits.

Never overfill the firechamber and also avoid over-sized pieces of wood which will 'slow' the fire down at the start but then could lead to over-firing.

Before refuelling open the Primary and Secondary air supply so that there is a good strong fire so that the embers are glowing red which will help the new fuel to start burning quickly. This will also ensure that there is no build-up of harmful gas which could be released into the room when the firechamber

door is opened.

Rake the embers and spread them out to make an even bed. You may need to add some kindling to re-establish the fire. Add the new wood as before ensuring that the logs are not tightly packed.

Newly refuelled wood always requires some additional air so make sure the Secondary air is back in the fully open position after refuelling. Do not adjust the Secondary air until the fire is burning well and you can see bright yellow vigorous flames.

Once the fire is established, usually after about 5 minutes, close the Primary air and adjust the flame pattern again to your requirements with the Secondary air (Airwash) control.

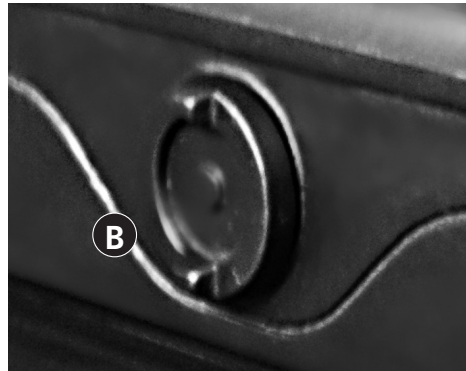

*Use the tool provided to adjust the Primary air control B at the base of the door. Turning the control anti-clockwise reduces the air supply to the firechamber reducing the burn rate, particularly of multi fuel*



## 4 Adding Smokeless Nuggets

If you prefer, you can also add some smokeless mineral fuel at this stage to prolong the life of the fire for overnight burning or to give additional heat when it is particularly cold. You may also need to re-open the Primary air to encourage the non-wood fuel to burn effectively depending on the load. Be very careful to avoid overloading the fire chamber.



*The recommended maximum multi fuel load:  
Photo shows a typical fuel load of approximately  
1.5kg of approved smokeless nuggets*

### Operating in a Smoke Control Area

To meet your legal obligations when operating this stove in a UK Smoke Control Area it must be operated correctly to minimise the amount of smoke it produces.

- Burn only dry fully seasoned wood with a moisture content of less than 20% (or approved smokeless solid fuels).
- Or burn Approved Smokeless Fuels
- This instruction book should be left with the end-user.

## BURNING MINERAL FUELS

*Do not use in a Smoke Control Area unless it is an Approved Smokeless Fuel (see [www.smokecontrol.defra.gov.uk](http://www.smokecontrol.defra.gov.uk)).*

Mineral fuels require much more air from below the fire for combustion than wood. This means (depending on your chimney / flue draught) that Primary air is generally needed throughout all of the burning phases. The Primary air should be fully open at the start of the lighting phase.

Burning mineral fuels also requires the grate to be riddled to clear ash so an adequate supply of Primary air can flow through it to the fuel load. How much you need to riddle is very much a matter of trial and error depending on the fuel type and burn rate. Always use a heat resistant tool such as a poker from a companion set to riddle and do this as quickly as possible to help maintain the temperature inside the firechamber. At the beginning of the lighting stage the grate should always be completely clear.

Light your fire in the traditional way with a small wood kindling fire and small amounts of your choice of mineral fuel placed lightly on top making sure to leave plenty of air space. Once the mineral fuel is burning well add more fuel until there is a good bed of burning fuel. Avoid stacking too much fuel against the back and sides of the stove as this could potentially overheat the metal components and cause permanent damage. Ideally, when fully burning the fire should look like a shallow dome.

When burning good quality mineral fuels the Airwash system (Secondary air) should not be needed to keep the glass clean, therefore this can be reduced. The Primary air control should then be used to adjust the flame pattern. You may find that a combination of subtle adjustments to both Primary and Secondary air controls could best suit your individual requirements.

When refuelling it is better to use smaller fuel loads more often which will provide you with a cleaner, more efficient burn. Just before refuelling, riddle the embers to help clear the ash build-up and re-establish the air passage underneath the mineral fuel. Spread the embers evenly with a poker.

Again, open the Primary air to maximise the heat in the remaining fuel so that when the new fuel is added it can get quickly established without 'damping' the fire.

Re-adjust the air settings once all the fuel is burning normally.

Remove the multi fuel ash by emptying the ash pan regularly – at least once a day. Do not let the ash build up under the grate as this will create a strong hot spot which could eventually warp or burn-out your grate.

## SOME SIMPLE TIPS

- 1** Small regular loads when refuelling will produce a more efficient and cleaner burning performance.
- 2** Avoid burning large amounts of wood with the Secondary air supply turned down as this will reduce the effectiveness of the Airwash system, as well as produce excessive smoke and create potential creosote build-up.
- 3** Burn on a high output for approximately 30 minutes each day to 'burn off' any potential soot and creosote build-up – but be careful not to over-fire the stove
- 4** Bright vibrant flames and a clean firechamber indicates that your stove is operating well.
- 5** Never overload the stove – it will be smoky and inefficient as well very slow to establish a good burn and could eventually possibly over-fire.

---

*Maximum fuel load: This should never be higher than the lowest part of the logo circle in the tertiary air plate at the back of the firechamber as shown.*

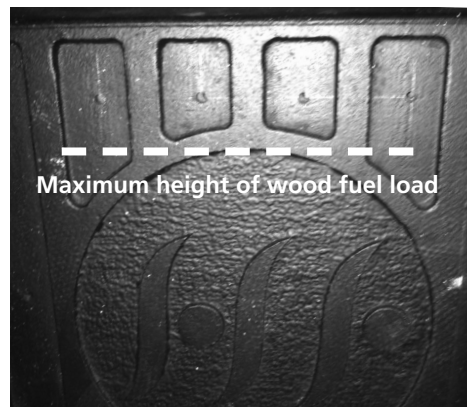

## REMOVING ASH

Wood will produce a lot less ash than multi fuels and it would not be unrealistic to expect to empty the ash pan every two or three days, depending on the fuel loads and operating times. Remember, you do not need to riddle wood ash during firing, but possibly only at the start when some Primary air is needed to aid the initial combustion. Wood ash can be composted and recycled in the garden.

However, if you intend to burn multi fuels then you should expect to empty the ash pan at least once a day, again depending on the number of hours you burn the stove.

Using a poker, riddle any ash or embers to help clear the grate. Riddling allows the ash to fall into the collection pan below the fire bed. The ash pan should never be allowed to over-fill as this will



*The forked end of the multi-purpose tool is inserted underneath the ash pan handle grip as shown above to create the ash pan handle. Always protect floor coverings from potential fly-ash*

limit the Primary air flow and cause excessive heat build-up which could eventually warp or burn out the grate.

Locate the operating tool in the slot at the front of the ash pan to make a handle and lift the pan from the stove. For safety reasons ash should be removed when the stove is cold. If this is not always possible then extra care should be taken and decorative and combustible surfaces, such as laminate floors or carpets, should be protected against potential accidental spillage.

Remember, even if the stove appears to be cold the ash could still be hot with the possibility of hidden live embers. Protective gloves should always be worn and the refuse ash placed in a non-combustible container. As you remove the ash from your home ensure that it is covered to protect it from any draught or wind which could blow the ash out of your container. All of this becomes second nature once you have used your stove for a few days.

## INSTALLATION

### CHECK-LIST

*This information is intended to outline the general principles of installing your stove. However, as each installation will vary and must comply with local, national and European building regulations, which could be different from country to country, it is unfortunately not possible for these guidelines to be comprehensive.*

- **Legal Requirements** Please note that, not only is it a legal requirement to ensure that your stove installation complies with all applicable building regulations, it is also a requirement of your Warranty that the stove is installed by a competent person such as a Hetas or INFO registered installer who will be fully aware of any building and safety regulations which apply to stove installations in your location.

#### Stove Location Checklist

- The existing constructional hearth (the main part of the hearth) is suitably constructed and is of a thickness that conforms to all applicable building regulations.
- The back hearth (the part of the hearth that the stove generally sits upon and which is usually within the fireplace recess or opening) is also suitably constructed and conforms to all applicable building regulations.
- The superimposed hearth (the thinner, usually decorative surface, which sits on the constructional part of the hearth) is suitably constructed and conforms to all applicable building regulations.
- The fireplace recess or opening is suitably constructed and conforms to all applicable building regulations and can accommodate the stove along with the safe minimum operating distances required (see page 21).
- Any adjacent walls, next to which a free-standing stove is installed, are of a suitable thickness and are of non-combustible material and conform to all applicable building regulations.
- The air supply is sufficient for full combustion of the stove's fuel and the health and safety of the room's occupants. Any extractor fans inside the room should be removed or permanently disabled. Note that in the UK stoves above 5kW output require a non-closable dedicated air supply within the room which must conform to applicable building regulations. The HF905-SE Precision I has been officially rated at 4.9kW output when burning wood or smokeless fuels.
- The chimney is of sufficient height, is suitably constructed and is in good condition and conforms to all applicable building regulations regarding stove installation. The minimum flue height required for the Precision I is 4.5 metres from the hearth to the top of the chimney terminal.
- The chimney has been swept and tested prior to installation.
- The proximity of all combustible materials to the intended stove installation conforms to the minimum requirements outlined within this handbook (page 5) as well as local, national and European building

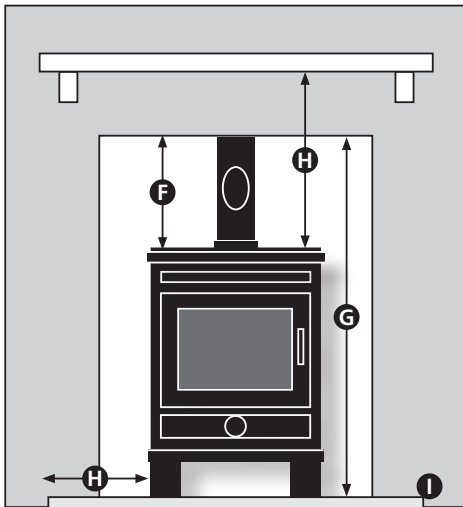
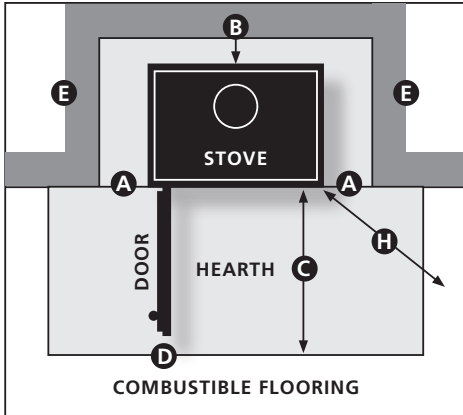

- A** Minimum Air Space: Sides 150mm (6")
- B** Minimum Air Space: Back 100mm (4")
- C** Minimum hearth from stove front: 225mm (9")
- D** or at least 50mm (2") beyond door swing
- E** Fireplace walls minimum: 75 mm (3") thick
- F** Minimum Height from lid to lintel: 300mm (12")
- G** Ideal aperture height: 1200mm (48")
- H** Minimum to combustibles: 500mm (20")
- I** Minimum hearth depth: 28mm (approx 1")

regulations, whichever is the greater. A combustible material is anything which can burn once it gets hot enough and includes skirting boards, wooden fire surrounds, wooden mantles, wallpaper, fabrics and floor coverings. Remember these materials could be concealed behind other materials which on the surface may appear to be non-combustible, for example, stud partitioned walls.

### GENERAL GUIDELINES

*Please refer specifically to current building regulations which apply to your country or region (see page 9). Adopt whichever provides the highest / safest margin.*

**The Hearth** The hearth should be made of solid non-combustible material, set on a firm and level base and should be at least 125mm (5") thick. This can include the thickness of any non-combustible floor under the hearth or non-combustible decorative surface. It must be capable of supporting the weight of the stove (when loaded) along with any attached flue pipes which bear down on the stove. This hearth must conform to local building regulations which may vary from country to country.

In England and Wales there is a minimum requirement for the hearth to project 500mm (20") in front of any brick or stone recess and 150mm (6") at each side of the recess. For a free-standing stove the minimum hearth size should be 840mm by 840mm (2'10" by 2'10" approx) and should provide the minimum clearances

for the stove which are outlined in this handbook. The hearth should extend by a minimum of 225mm (9") from the front of the stove (which includes the edge of the ash lip). As a general rule it is best to extend the hearth to at least 75mm (3") beyond the furthest out-swing of the stove door to avoid any potential live ash held on the door falling on to combustible flooring or floor coverings. If the top of the hearth and any combustible floor coverings are level with each other then a retaining fender should be fitted to warn occupants of the hearth area. Alternatively, a 28mm (1.1") change in level provided by a decorative non-combustible material such as stone, marble, granite, ceramic tiles etc could be used.

Please note that some materials, such as marble, may not be suitable when used as a single sheet and will need to be pieced together to allow for expansion from the heat of the stove. Your stove dealer or installer should be able to advise you about this.

**The 'Fireplace'** The stove can be sited within a brick or stone fireplace recess or used free-standing. The fireplace side and rear walls should be at least 75mm thick and made of non-combustible brick or stone. In a fireplace setting you should allow a minimum distance of 100mm (4") from the back of the stove and 150mm (6") at either side with at least 300mm (12") from the top of the stove. Ideally, the overall height of the fireplace aperture should be at least 1200mm (4') high.

Providing adequate air space around

the stove will allow the stove to radiate heat and circulate warm air around the room. It will also prevent structural damage to the walls and potentially damaging over-heating of the stove. If it is not possible to maintain these spaces they could be reduced to 100mm (4") at the sides but only if this can be compensated with twice the equivalent air space at the top of the stove and the non-combustible wall parts are at least 200mm (8") thick.

Walls adjacent to free-standing stoves should be made of non-combustible material and be a minimum of 200mm (8") thick.

**Flue Draught** The minimum flue draught requirement for the HF905-SE is 3.3g/s (wood) and 3.7g/s (smokeless fuels).

**The Chimney, Flue and Flexible Liners** Other appliances should not share or be connected to the same flue system or chimney.

If you are using an existing chimney and it has been checked for condition and suitability (see below), in the interests of safety you must ensure that it is swept before the stove is installed, even if it has never been used or you intend to use a flexible liner. To find a local registered sweep visit The National Association of Chimney Sweeps at [www.chimneyworks.co.uk](http://www.chimneyworks.co.uk) or the Guild of Master Chimney Sweeps at [www.guildofmasterchimneysweeps.co.uk](http://www.guildofmasterchimneysweeps.co.uk).

The recommended minimum height for the chimney / flue system from the

top of the hearth base to the top of the chimney terminal is 4.5m (15'). If this is not possible then a 'spinner' type cowl, to compensate for the potential limited draught, should always be specified and specialist advice sought on the correct type.

The Precision I features optional top or rear 125mm (5") diameter flue outlets and as a DEFRA Approved Smoke Exempt stove this *does not* require the installation specification to provide for an increasing adaptor to take the flue pipe and liner to 150mm (6") when burning wood.

Under no circumstances should the stove's 125mm diameter flue be reduced in any part of the flue system as this could cause a build-up of dangerous carbon monoxide gas.

A free-standing stove will generally require the flue to exit the room either through the ceiling, roof or wall. Therefore such installations require a specialist knowledge of building regulations and approved flue components which, unfortunately, is beyond the scope of these guidelines. In this instance always consult an approved installer who has experience of this type of installation.

When your new Horse Flame stove is installed it should be possible to sweep the chimney through the stove by simply removing the baffle plate. However, the installer must also provide an alternative means, such as a soot door with adequate air-tight seal, in the chimney wall to be able to clean the whole of the chimney / flue system. In

any event we would recommend that, where possible, the connecting flue pipe features at least one easily accessible inspection hatch near the top of the stove and that any bends which have been used also have inspection hatches, irrespective of any other hatches in the system.

Since stoves create flue gases at a much greater temperature than those produced by an open fire or gas appliance it does not necessarily follow that your chimney will function adequately (or safely) when your new stove is installed. The best way to ensure that you have a fully functioning flue system is to fit an approved flexible multi fuel flue liner.

Current building Regulations in England and Wales do not yet automatically require an existing chimney to be lined when a new stove is fitted. However, Horse Flame strongly recommend fitting a liner for the following reasons:

- A flue liner is a major 'quantifiable' component in a total and fully functioning flue system. As such it will provide a consistent flue draught from the stove through to the chimney terminal and when back-filled with vermiculite will deliver much needed insulation to keep flue gases as hot as possible which will help minimise the amount of smoke produced. It will also improve the stove's operation with greater control over the fuel burn rate and improved environmental and fuel efficiency.
- Your existing chimney could leak smoke, fumes and potentially

dangerous 'invisible' carbon monoxide into other parts of the building.

- Condensation or creosote 'tar', often associated with burning wood, could eventually seep through the walls, particularly if they are made of old or porous brick and / or are jointed with lime mortar, eventually causing unsightly stains on decorative coverings.
- Stoves work best with the correct draught. Pre-1965 chimneys which have been built for open fires have larger (and irregular shaped) voids than those best suited for a modern stove and thus could reduce the effectiveness of the flue draught by making the flue too cold and difficult to warm. This is a particular problem if the chimney breast is on an outside wall and / or is subject to a strong prevailing wind.
- The interior surfaces of older flues could be eroded and also have rough surfaces which could cause resistance to the flow of gases and consequently result in poor up-draught.
- Unfortunately many houses built since 1965 with clay or concrete chimney liners suffer from these being poorly installed, either through being fitted the wrong way up or not receiving an appropriate application of mortar to make a complete seal on each joint. Even though not particularly old, this could still potentially cause leaking smoke and fumes or condensation stains

Your approved installer will be able to advise you on the suitability of your chimney after undertaking a thorough inspection and smoke test. Any solid

fuel flexible liner which is specified should be double skinned stainless steel, either 904L or 316Ti grade and be CE marked and / or Hetas Approved.

The British Flue and Chimney Manufacturers Association website, accessed through [www.feta.co.uk/bfcma](http://www.feta.co.uk/bfcma), produces an authoritative and informative download *Yellow Guide* to solid fuel flues and chimneys.

**Chimney Terminal** The existing chimney pot or terminal must be suitable for stove installation and should not restrict the smoke and fumes from the stove. It must provide at least the same outlet area as the flue pipe. It may be that your existing chimney terminal has been replaced with a ventilating terminal if the fireplace has been closed off at some point and this will need replacing.

Your installer will be able to advise you on the correct specification of any new cowl or terminal. Cowls have the additional advantage of limiting rain entering the flue system which could cause the inside of the stove to rust when it is not being used, particularly during the long periods outside the heating season.



## COMMISSIONING

- 1 Confirm that all internal parts of the stove are correctly fitted, including the baffle plate
- 2 Confirm that the door closes correctly and that the latch mechanism and door seals work to make an air-tight seal
- 3 Warm the chimney and carry out a final smoke draw test
- 4 Light the stove with a gentle fire, allowing the stove to increase to an operational temperature level and check that no combustion products are entering the room
- 5 Ensure that the Primary and Secondary air controls are fully operational
- 6 Explain the safe operation of the stove to the user and the importance of using the correct fuel types
- 7 Explain the requirements of using an approved fireguard whenever children, the elderly or the infirm are likely to be in the vicinity of the stove
- 8 Make sure that the customer receives this copy of the *Instruction Manual*
- 9 Complete the relevant parts of the *Horse Flame Warranty Card* with your Hetas / INFO or competent persons registration number and contact details

## TROUBLE-SHOOTING

### CHIMNEY FIRE

If your stove has been installed correctly and you have also operated it correctly and regularly carried out the recommended routine checks on page 29 then it is unlikely that you will ever experience a chimney fire, which can be highly dangerous.

Chimney fires can be detected by an unusual roaring sound and / or unusual vibrations coming from the chimney breast, the stove itself or connecting flue pipe. The sound is not to be confused with the gentle 'rushing' sound you may normally hear when a stove has a well performing draught. You may also see sparks or flames exiting from the chimney terminal.

#### • **Prevention**

If you suspect a chimney fire then immediately close the Primary and Secondary air controls, evacuate the building and call the Fire Brigade. *Never* open the stove door as this will make the chimney fire worse by providing additional combustion air. Do not re-enter the building until you have been advised by the Fire Brigade that it is safe.

Do not re-light the stove until the flue system has been thoroughly inspected by an approved installer or chimney sweep and any necessary repairs have been carried out.

#### • **Causes: Inadequate cleaning**

Chimney fires occur when soot and creosote have built up to such a level that they ignite. It is important

therefore that your flue system, chimney closure (registration) plate and chimney has as many cleaning access points as practicable to enable comprehensive removal of soot, creosote and other debris from every point in the system. This will also minimise the amount of time it takes for a qualified sweep to clean the system making the system safer and its cleaning more cost-effective in the long run.

- **Causes: Continuous low burning**

To discourage the potential for such soot and creosote build-ups, long periods of consistent slow or overnight burning should be avoided or that these should at least be compensated for by regular burning on full output for short periods (eg 30 minutes per day) to help burn off any likely deposits before they become problematic.

A good flue temperature thermostat will indicate the flue gas temperature which promotes the conditions to create creosote deposits (around less than 120C°) and therefore the operating temperature to be avoided and is another good reason why we strongly recommend the small investment in this simple to use device.

- **Causes: Poor fuel choice** As previously mentioned unseasoned or damp wood or fuel should always be avoided as these produce excessive soot and creosote. See page 10

---

## STOVE, FLUE OR OTHER COMPONENTS GLOWING RED

- **Prevention**

The Primary and Secondary air controls should be immediately closed to let the fire die down to an acceptable level and to reduce the heat output which will in turn eliminate the glow from the over-heated components. Over-firing is dangerous and could permanently damage or warp your stove and its components. The effects of over-firing are fairly obvious to anyone in the stove industry and will invalidate your Horse Flame Warranty. Check the stove and the flue system for signs of damage before you re-use the stove.

- **Causes: Over-Firing** This is caused by using the stove at a higher output than recommended for prolonged periods of time and / or over-filling the firebox with fuel. The excessive heat in the flue system produced by over-firing could potentially also lead to a chimney fire (See 'Chimney Fire' above).

---

## SMOKE AND FUMES ESCAPING INTO THE ROOM

When properly installed and operated your stove should not normally emit fumes or smoke into the room. When first using the stove it is normal to experience paint fumes or see light smoke rising from some of the stove's painted surfaces, but these should eventually pass as the paint cures. Occasional minor smoke escape may also occur during refuelling process. However, persistent smoke or fumes could be dangerous and in this

situation you should take immediate avoiding action.

- **Prevention**

Open doors and windows to ventilate the room and let the fire go out to allow the stove to cool. Never pour water onto the fire as this could cause cast iron components to break

*Most importantly, never re-light the stove until the problem has been identified and solved. If in doubt, in the first instance always seek the expert advice of your approved installer, or authorised Horse Flame dealer.*

There are a number of factors, either alone or combined, which could cause such problems:

- **Causes: A blockage** When safe to do so, examine the flue-way above the baffle plate as well as the flue pipe and chimney system via the appropriate inspection hatches and clear any soot blockages. Excessive deposits could also indicate that the chimney or flue itself also needs cleaning (see page 31).

- **Causes: Inadequate supply of combustion air** Check that any permanent air vent fitted to supply the extra combustion air required for the stove has not been accidentally blocked. Remember there should never be an extractor fan in the same room as a stove, even in a large open plan area. A simple way of checking whether or not the stove is receiving enough combustion air is to open a window in the same room as the stove whilst the stove is operating. If this improves the problem then this would certainly indicate that the stove is being starved of

combustion air and the advice of the original installer should be sought.

- **Causes: Extreme weather**

**conditions** High winds or freezing temperatures can also temporarily effect the performance of the chimney draught and consequently its effectiveness in removing smoke and fumes from the stove's firechamber. In the case of freezing temperatures it is important to build a larger pre-fire than normal to quickly provide the additional heat needed to warm the flue system and to counteract the much lower temperatures at the exit point of the chimney. Please see the section on lighting your stove on page 13.

- **Causes: High winds** If the problem is associated with high winds and it becomes a regular occurrence, then you will need to fit a specialist chimney cowl. These are designed to provide a stable draught and prevent specific types of problems. Specifying the right cowl should always be left to an approved installer.

- **Causes: Flue Exit** Check, especially at the beginning of the heating season, that summer tree growth has not interfered with the free passage of smoke and flue gases from the chimney top.

---

## OVERHEATING OR EXCESSIVE FUEL CONSUMPTION

This can be caused by a number of factors.

- **Causes: Excessive Chimney Draught** This limits the effectiveness

of the air controls so that the fire burns with very strong bright yellow flames and with very little difference when the air controls are operated. In such circumstances an adjustable draught stabiliser in the flue pipe may need to be fitted to ensure that the stove will always operate under a stable draught to allow the stove's controls to function correctly. In the interests of safety, because draught stabilisers limit the exit of flue gases from the stove, they should only ever be specified, fitted and subsequently tested by an approved installer.

- **Causes: Fuel** The fuel itself may be of poor quality. For example pine and other softwoods will burn much quicker than a good hard wood log, such as Oak. Please read the section on hard and soft woods on page 10.

- **Causes: Faulty Door Seals** The rope seals around the firechamber door could have become worn and may not create the air-tight seal needed for the Primary and Secondary air controls to function correctly. When the stove is cold, you can easily check this seal by placing strips of paper at various points between the door and chamber and checking that when the door is closed it grips this paper. Any paper which can be removed easily would indicate a weakness of the door seal in that particular spot, in which case a complete new rope seal should be fitted. See the section on fitting a rope seal, page 32.

---

## STOVE NOT PROVIDING ENOUGH HEAT

This problem is also usually indicated by dull orange lifeless flames and wood that remains black when burning instead of light grey. A flue temperature gauge will provide you with the best indication of whether or not your stove is operating effectively.

- **Causes: Poor fuel** Poor heat output is more than likely caused by poor fuel, such as 'green' or unseasoned wood. We cannot over-estimate how critical it is to use fully seasoned dry wood.

The easiest way to check whether your wood is fully seasoned is to invest in a moisture meter specifically designed for testing wood fuel. These are relatively inexpensive and can be purchased from your stove dealer. When you bear in mind that seasoned wood with a moisture content of less than 20% will give you approximately 50% more heat than unseasoned wood, a moisture meter is modest investment which will more than pay for itself. See page 10

Unseasoned wood introduces unwanted moisture into the fire-chamber, reducing the stove's operating temperature and thus the effectiveness of the air wash system. In addition it will cause problems of increased soot and harmful creosote deposits within the flue system.

Softwoods such as Pine produce significantly less heat output than hardwoods.

- **Causes: Air controls** Ensure that you fully understand the difference that using the Primary and Secondary air

controls make to the performance of the stove and the best way to burn your type of fuel. See pages 13 – 18

• **Causes: Inadequate Combustion**

**Air** A stove starved of combustion air, even when the Primary and Secondary air controls are in the fully open position, will provide limited heat output. Check that any permanent air vent fitted to supply the extra combustion air required for the stove has not been accidentally blocked. Remember there should never be an extractor fan in the same room as a stove, even in a large open plan area.

A simple way of confirming whether or not the stove is receiving enough combustion air is to open a window in the same room as the stove. If this improves the problem then this would certainly indicate that the stove is being starved of combustion air and the advice of the original installer should be sought.

• **Causes: Blockages** When safe to do so, examine the flue-way above the baffle plate as well as the flue pipe and chimney system via the appropriate inspection hatches and clear any soot blockages. Excessive deposits could also indicate that the chimney or flue itself also needs cleaning. See page 31

---

## GLASS STAINING OR BLACKENING

Glass can be cleaned easily if it is undertaken regularly and the deposits are not allowed to build up. A proprietary stove glass spray or gel is strongly recommended – see page 31.

• **Causes: Air Controls** Ensure that you fully understand how the Airwash system works and that you have determined, through some trial and air, the correct balance between Primary and Secondary air that your stove needs. Generally, try to use more Secondary air as this air flows down and over the glass to help burn and wash away any particulates that have accumulated there. See pages 13 – 18

• **Causes: Poor fuel** Burning damp or unseasoned wood will cause the glass to stain as the moisture from the fuel considerably reduces the firechamber temperature reducing the effectiveness of the Airwash system. 'Green' wood will also encourage sticky deposits on the glass which will prove difficult for the impaired Airwash system to remove.

• **Causes: Continuous low burning** Continuously burning your stove with a very low flame, such as slow overnight burning will also cause this problem because the Airwash does not get hot enough and some blackening of the glass should be considered a 'trade-off'. In this instance, if you're sure that the fuel is seasoned and dry, then burning the stove at very high temperature for a short period after a long slow burn will usually burn off any sooty deposits. Glass can be cleaned easily if it is undertaken regularly and the deposits are not allowed to build up. A proprietary stove glass spray or gel is strongly recommended – see page 31.

---

## ROUTINE CHECKS

During routine checks if you notice anything wrong with your stove then it should be rectified immediately. Never use a stove that you know is not fully functioning – this includes flue components.

- Check your flue system at least once a month using one of the recommended inspection hatches in the flue pipe. After a few checks you will notice a pattern of soot build-up to enable you to determine the inspection and cleaning period best suited to your stove's operation.
- Check and clear the stove's baffle plate and flue way at least once a month – see page 31.
- Regularly visually inspect any flue pipe joints where fire cement has been used and replace any missing or damaged cement seals using the appropriate heat-resistant fire cement.
- Make sure the door maintains a good tight fit and visually inspect the door rope seals for fraying or other signs of wear. Test the seal if you suspect that it is no longer air-tight – see page 32.
- Check that the glass is not chipped or cracked and that the glass sealing tape is still in good condition. Replace if necessary – see page 32.

## STANDING DOWN

There will be some point in the year when you will not need to use your stove for a considerable time and taking care to clean it thoroughly then will save you much time later. This is also a good time to get your chimney swept too as this will prevent any soot build up from falling inside the stove 'caking' and blocking the flue way.

- Remove and clean any deposits from the top of the baffle plate and check for wear.
- Remove any debris and deposits from the inside of the stove particularly at the entrance to the flue way.
- Empty the ash pan and thoroughly clean out the ash pan chamber.
- Check all rope seals and replace damaged ropes that do not provide a good seal – see page 32.
- Check any fire cement bonds around the flue joints, particularly where they connect to the stove. Remove any loose cement and re-seal.
- Check the vermiculite firebricks and replace any that are becoming very thin or have crumbled to reveal the cast iron sides of the stove.
- Check the grate for signs of wear. Excessive wear, such as grate bars or log retaining bars which are bent or warped, could be an indication of over-firing or using inappropriate fuels such as petroleum coke. Order genuine replacement components from your authorised Horse Flame dealer (or in case of difficulty your National Distributor) – see back cover.

## ROUTINE MAINTENANCE

### • **Baffle Plate and Flue Way**

During the heating season check the flue way and baffle plate at least once a month to start with and remove any soot deposits. Should these be excessive then have your chimney and flue cleaned. At the same time review your choice of fuel and the way that you operate the stove.

Regular long periods of slow or overnight burning can create excessive soot because the stove is not operating at the temperature required to burn off most of the sooty. Damp or unseasoned wood will also have similar effect. To find a local registered sweep visit [www.guildofmasterchimneysweeps.co.uk](http://www.guildofmasterchimneysweeps.co.uk) or [www.chimneyworks.co.uk](http://www.chimneyworks.co.uk).

• **Chimney Cleaning** The Precision I can be swept through the stove by simply removing the baffle plate – see page 7. Sweep your chimney before installation and then at the end of each heating season when you stand down your stove. Burning seasoned dry wood means that you will probably need to sweep every three months. The amount of soot deposits removed each time is a good indication of how often you should sweep and as you begin to understand your stove and the wood you burn you can adjust the cleaning intervals accordingly. If in doubt seek the advice of a registered chimney sweep who has experience of stoves.

• **Firebricks** Regularly inspect the condition of the firebricks. Please note that minor cracks are perfectly normal due to the high temperatures created

inside the stove. If necessary small cracks can be repaired using a proprietary heat resistant fire cement (your stove dealer should be able to advise you). Bricks only need replacing if they have crumbled or part of the brick has broken away revealing the stove bodywork. Firebricks are deemed as 'consumable' and are therefore not covered under your Warranty.

To replace a firebrick, first remove the baffle plate by lifting this up and dropping it down to clear the baffle plate retaining ledge at the back of the stove. There are two loosely fitted firebrick retaining 'clips', (see *photo left*) on the right and left hand sides at the top of the fire bricks, these can easily be lifted out to release the firebricks.

• **Cleaning the Glass** Using damp or 'green' unseasoned wood, filling with small fuel loads or operating the stove at low temperatures (slow overnight burning) will reduce the effectiveness of the Airwash system and cause the glass to stain. Do not allow such staining to build up as it will become more difficult to remove after each firing. When used regularly, a proprietary scratch-resistant stove glass cleaning gel or spray, which can be supplied by your stove dealer, removed with a soft cloth, should be sufficient to keep the glass in pristine condition. Make sure the glass is cold before you apply such cleaners, as applying a cold solution to hot glass could create a thermal shock within the glass causing the glass to crack. Also make sure that all traces of the cleaning fluid have been removed and the glass

is thoroughly dry as any residue can be 'baked' on causing unsightly smearing. Read the section on fuels on page 10.

- **Replacing Glass** Never use your stove if it has cracked or missing glass. Your Horse Flame dealer can quickly supply you with a new piece of heat resistant glass should you ever need it – just let them know the stove name and model number. Only use heat-resistant glass as this is made to withstand temperatures of up to 800°C.

Remove the screws and glass clamp washers from each corner and place them in a safe place. Always use the correct sized Phillips crosshead screwdriver and use releasing oil if the screws prove difficult to remove. Be careful not to dislodge the ribbon seal. If this is damaged or worn replace it completely. Loose ribbon can be held in place with rope seal glue available from your dealer. Lubricate the screws and holes and reverse the process, being careful not to over-tighten the screws and clamps in case you break the glass.

- **Paint Finish** Your stove has been finished with heat-resistant paint (except for enamelled models) and is very easy to maintain. Regularly remove ash and dust from surfaces with a soft cloth or brush. To maintain the original paint finish you can use traditional 'stove black' polish which your Horse Flame dealer can supply. Make sure the stove is cold and use protective gloves as this type of polish can cause deep staining to the skin and fingernails.

Repair worn or scratched surfaces with a proprietary heat-resistant spray paint made specially for stoves, also available from your stove dealer. Never use an aerosol spray on, or near, the stove when it is burning or it is hot.

- **Door Rope Seals** It is important that you maintain a tight door seal as this prevents unwanted air leaking into the firechamber and helps make the Primary and Secondary air more effective in controlling the fire.

When the stove is cold, to check the door stove seal, place strips of paper between the door and 'door frame' and shut the door. If you have to pull hard to remove these or they tear, then you have an effective door seal. If these can be easily removed or if they slide around you will need to replace the door seal. Your new Horse Flame stove is supplied with a spare rope seal for the door. To replace, carefully remove the old seal and completely clean the seal channel of debris and old glue. Use liberal amounts of proprietary heat resistant fire rope glue to hold the rope in position and glue both ends to ensure a well-sealed joint.

Replacement rope should be 9mm dia.

- **Replacement Parts** In the interests of safety, only ever use genuine Horse Flame replacement components – see *back cover*.



## **HORSE FLAME® WARRANTY**

*Your new stove has been CE tested in the UK to ensure that it meets strict constructional, performance and safety standards. It is not the responsibility of Horse Flame to ensure that the appliance is installed and operating correctly at the time of the installation.*

Horse Flame offers the original retail purchaser a limited 5 year warranty. Claims under this warranty must be reported in the first instance to the dealer you purchased the stove from. All claims *must* follow this procedure.

Your stove is guaranteed against defects subject to the following conditions.

- 1** The stove must have been installed by an appropriately qualified installer and upon completion of the installation a certificate of compliance to local building regulations issued.
- 2** The sales receipt or invoice must be kept as proof of purchase.
- 3** The serial number of the stove must not be damaged or missing.
- 4** You must not have used the stove to burn any of the prohibited fuels listed.
- 5** The stove must have been continuously kept in a serviceable condition and you must not have allowed the stove to corrode.
- 6** You must not have modified the construction of the stove in any way.
- 7** The stove must not have been used for commercial purposes (eg rented or holiday accommodation, public bar, where the stove's operation could be subject to abuse).

Horse Flame guarantee that your product will be free from defective parts, materials and workmanship at the time of purchase by the original consumer for a period of 1 year for components (parts and labour), excluding consumable parts and 5 years for the bodywork casing and door (parts and 1 year labour).

The warranty does not cover parts deemed to be consumables. These include paint, firebricks, vermiculite panels, smoke deflection plates (baffle plates), gaskets, rope seals and glass.

Horse Flame will repair or replace at its option any stove or stove part thereof found to be defective under these terms.

### **Limits of Warranty**

This warranty is not transferable and applies to the original retail purchaser only. It does not cover the failure of the appliance due to accidental damage, misuse or abuse, modification, illegal installation, repairs (other than those by the authorised dealer) or failure to maintain the stove in a serviceable condition.

Under no circumstances shall Horse Flame be liable for any incidental or consequential damage claims of any nature whatsoever arising from the non-conformance of the stove under the terms of the manufacturer's warranty. These include loss of profit, commercial losses, transport costs and damage during transport, costs in connection with any dismantling and reassembling of the stove and its installation components.

## ANNUAL SERVICE

In the interests of safety it is important that your Horse Flame® stove is serviced on an annual basis in accordance with the instructions outlined below. This should be carried out by a suitably qualified person such as your original approved installer, a Hetas or INFO registered installer or your authorised Horse Flame dealer.

When the stove is cold strip, clean and inspect it.

**Internal Components** Remove and inspect the following:

- Baffle Plate
- Side Firebricks
- Grate Assembly
- Ash Pan

Use a wire brush to clean the baffle plate and grate assembly. Use a soft brush on the firebricks and handle these with care as they become fragile with continuous use. Wire brush the inside of the stove and remove all ash and debris from inside the stove and the ash pan chamber.

Check all parts for wear or damage and replace as necessary. Some surface wear is normal on firebricks and these only need replacing when they are very thin or have crumbled to reveal the stove bodywork.

Re-fit all the internal parts.

**Stove Glass** Check the glass for chips or cracks and the glass seal condition and replace if necessary. Thoroughly clean the stove glass on both sides.

**Door Seal** Check that this continues to make an air-tight seal and replace if necessary. Ensure that the new rope joint is also in the middle at the base of the rope seal channel. Replacement door rope seal should be 9mm dia.  
*See page 32*

**External Bodywork** All external surfaces should be dusted with a soft cloth or light brush.

- Examine all paintwork for signs of wear and re-paint these areas using an appropriate heat-resistant aerosol paint.  
*Warning: do not use the aerosol if the stove is alight or hot.*
- When the aerosol paint has dried, apply traditional stove black polish to all painted surfaces
- Lightly oil the hinges and locking mechanism

**Air Controls** When standing down at the end of the heating season these should be left on the open position to allow some movement of air which will help avoid condensation and moisture building up inside the stove and flue system. These can be closed up to 50% if it gets too draughty.

**Flue Pipe Connections** Check all flue collar and pipe connections, where applicable, for any crumbling or missing fire cement seals. Remove any failed seals and re-seal using the appropriate heat-resistant fire cement.

**Important** In the interests of safety use only genuine Horse Flame replacement parts which are readily available from your authorised dealer – *see back cover.*

---

## FIRST SERVICE

Work carried out:

Date

Next Service Due

Signed

Print

Dealer's Stamp or HETAS Registration Number

---

## SECOND SERVICE

Work carried out:

Date

Next Service Due

Signed

Print

Dealer's Stamp or HETAS Registration Number

---

## THIRD SERVICE

Work carried out:

Date

Next Service Due

Signed

Print

Dealer's Stamp or HETAS Registration Number

---

## FOURTH SERVICE

Work carried out:

Date

Next Service Due

Signed

Print

Dealer's Stamp or HETAS Registration Number

---

## FIFTH SERVICE

Work carried out:

Date

Next Service Due

Signed

Print

Dealer's Stamp or HETAS Registration Number

---



---

## **Authorised Horse Flame® Distributors**

*UK Mainland – including England,  
Wales, Scotland and the Isle of Man*

Hi-Flame Fireplace UK Limited  
5A Holmes Chapel Business Park  
Manor Lane  
Holmes Chapel  
Cheshire  
CW4 8AF

### *Northern Ireland*

AJ Plumbing Supplies Limited  
Greenbank Industrial Estate  
Rampart Road  
Newry  
County Down  
BT34 2QU

### *Republic of Ireland*

The Stove Yard  
RPG Industries Limited  
Kiltonga Industrial Estate  
Belfast Road  
Newtownards  
County Down  
BT23 4TJ

## **Horse Flame Spares Service**

In the interests of safety, only ever use genuine Horse Flame replacement components. Once you have identified the component you need (visit the Hi-Flame website below for a comprehensive list of spares) this will be readily available from your authorised Horse Flame dealer in the first instance, or from the authorised distributors listed opposite.

© Horse Flame 2007, 2008, 2009, 2010, 2011 and 2012  
All rights reserved. Booklet contents may not be copied in whole or in part without the prior written permission of the copyright holder. Horse Flame® is the original trading and registered name of Hi-Flame Fireplace (UK) Limited

[www.hi-flame.com](http://www.hi-flame.com)