

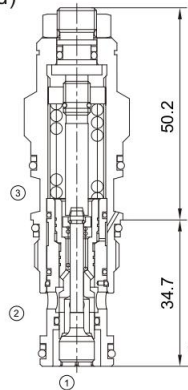

MCBCA/MCBCG MCBCH

平衡阀(标准型)
Counterbalance Valve
(Standard)



压力-流量性能曲线
Performance Curve Pressure
Drop vs. Flow

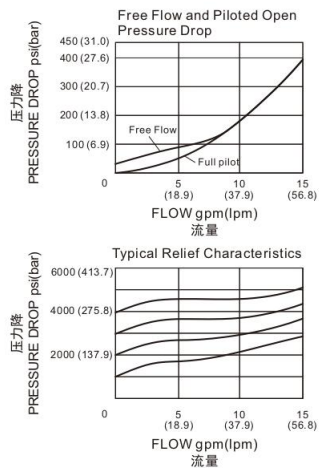

机能符号 Symbol

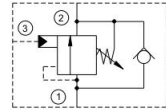

技术参数 Specifications

· 工作压力 Operating Pressure	280BAR(MCBCA) 350BAR(MCBCG/MCBCH)
· 流量 Flow	60L/min
· 内泄漏 Internal Leakage	5 drops/min. max. to 85% of normal setting
· 先导比 Pilot Ratio	3:1(MCBCA)/4.5:1(MCBCG)/10:1(MCBCH)
· 温度 Temperature	-30°C to +120°C (-22°F to +250°F)
· 插孔 Cavity	T-11A see page K-2
· 流体 Fluids	Mineral-based fluids with viscosities of 7.4 to 420 cSt.

产品特性 Features

- 平衡阀的设定值应该至少为负载压力值的1.3倍。
The setting value of the balance valve should be at least 1.3 times of the load pressure value.
- 2口的背压将会增加溢流值, 增加值为 (1+先导比) × 压力值
Backpressure at port 2 adds to the effective relief setting at a ratio of 1 plus the pilot ratio times the backpressure
- 标准设定下, 阀的复位压力值高于阀开启值的85%。当设定值小于标准设定值, 复位压力值的百分比将相应变小
Reseat exceeds 85% of set pressure when the valve is standard set. Settings lower than the standard set pressure may result in lower reseal percentages

工作 Operation

带先导协助开启的平衡阀是用来控制超驰负载。它允许油液从方向阀(口2)到负载口(口1)单向自由流通, 同时直动式, 先导协助溢流阀功能可以控制从口1到口2的液流。口3的先导协助以先导比率的作用系数降低了溢流功能的有效设定值。此阀还被称作运动控制阀或者越过中心阀
Counterbalance Valve with pilot assist are meant to control an overrunning load. The check valve allows free flow from the directional valve (port 2) to the load (port 1) while a direct-acting, pilot-assisted relief valve controls flow from port 1 to port 2. Pilot assist at port 3 lowers the effective setting of the relief valve at a rate determined by the pilot ratio. Other names for this valve include motion control valve and over-center valve.

安装尺寸 INSTALLATION DIMENSIONS

全调3.75圈
Number of Counter-clockwise Turns

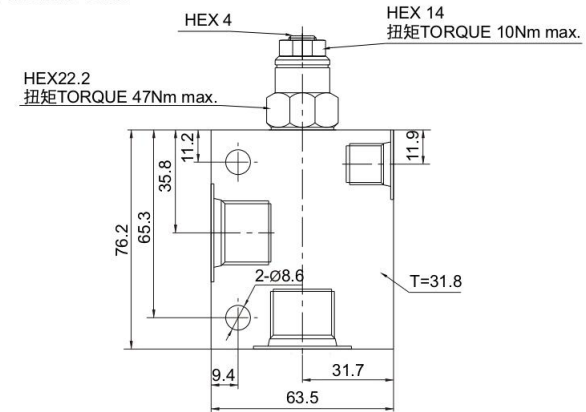

订购型号 Order Type

MCBC * - * * * - * *
I II III IV V VI

- | | | |
|---|---|---|
| <p>I. 先导比 Pilot Ratio
A=3:1
G=4.5:1
H=10:1</p> <p>II. 调节方式 adjustment
L=螺钉调整 Screw Adjust</p> | <p>III. 调压范围 Pressure Range
MCBCA:
H=1000-4000psi(70-280bar)
Preset:3000psi(210bar)(Check:1.7bar)
I=400-1500psi(28-105bar)
Preset:1000psi(70bar)(Check:1.7bar)
A=1000-4000psi(70-280bar)
Preset:3000psi(210bar)(Check:0.3bar)
B=400-1500psi(28-105bar)
Preset:1000psi(70bar)(Check:0.3bar)
MCBCG/MCBCH:
J=2000-5000psi(140-350bar)
Preset:3000psi(210bar)(Check:1.7bar)
K=1000-2500psi(70-175bar)
Preset:2000psi(140bar)(Check:1.7bar)
C=2000-5000psi(140-350bar)
Preset:3000psi(210bar)(Check:0.3bar)
D=1000-2500psi(70-175bar)
Preset:2000psi(140bar)(Check:0.3bar)</p> | <p>IV. 油封 Seal-Kits
N=丁腈橡胶 Buna N
V=氟橡胶 Viton</p> <p>V. 阀块材质 BODY MATERIAL
A=6061-T6铝
耐压强度207Bar
6061-T6 aluminum alloy rated at 207Bar
S=钢材 耐压强度350Bar
steel rated at 350Bar</p> <p>VI. 阀块油口 BODY PORTING
6T=SAE 6T
8T=SAE 8T
3G=G3/8
3N=NPT3/8
其他螺纹油口是可选择的
Other porting is available</p> |
|---|---|---|