

HUAJING A LEADING TRAILER PARTS
MANUFACTURER IN ASIA

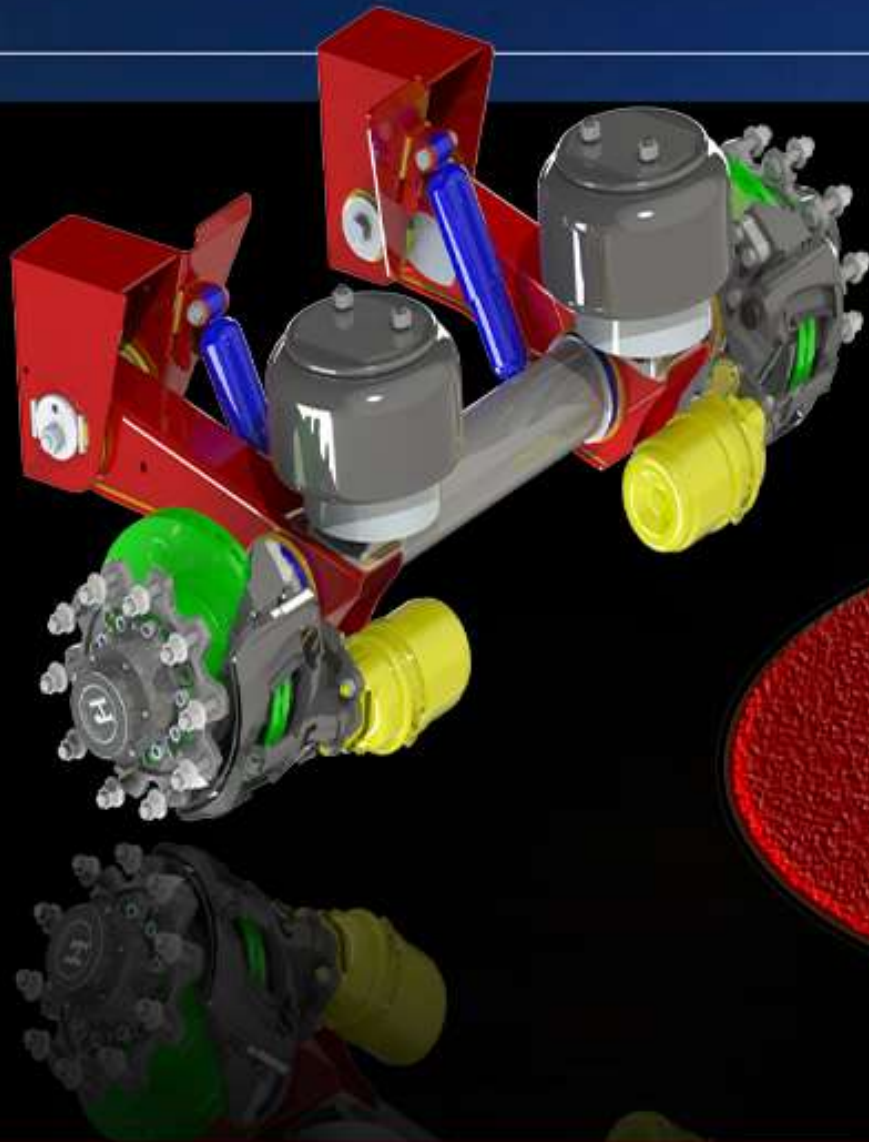

HJD10R08P

50万公里免维护盘刹车
轴+美式轻型空气悬挂
产品介绍

GHANGZHOU HUAJING MACHING MANUFACTURE CO. LTD

HJD10R08P

车轴特点

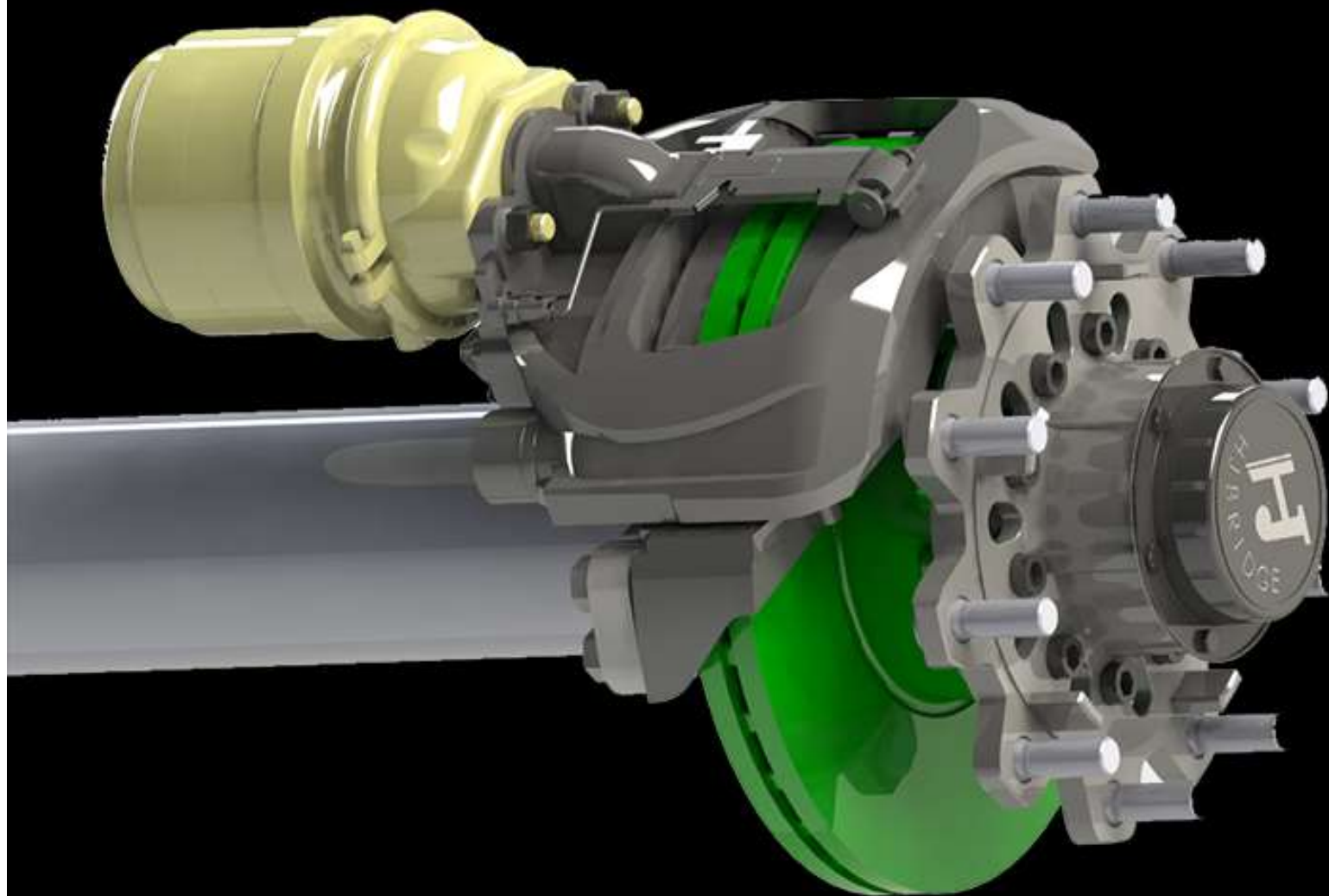

GUANG ZHOU HUAJING MACHINE
MANUFACTURE CO.LTD

HUAJING A LEADING TRAILER PARTS MANUFACTURER IN ASIA

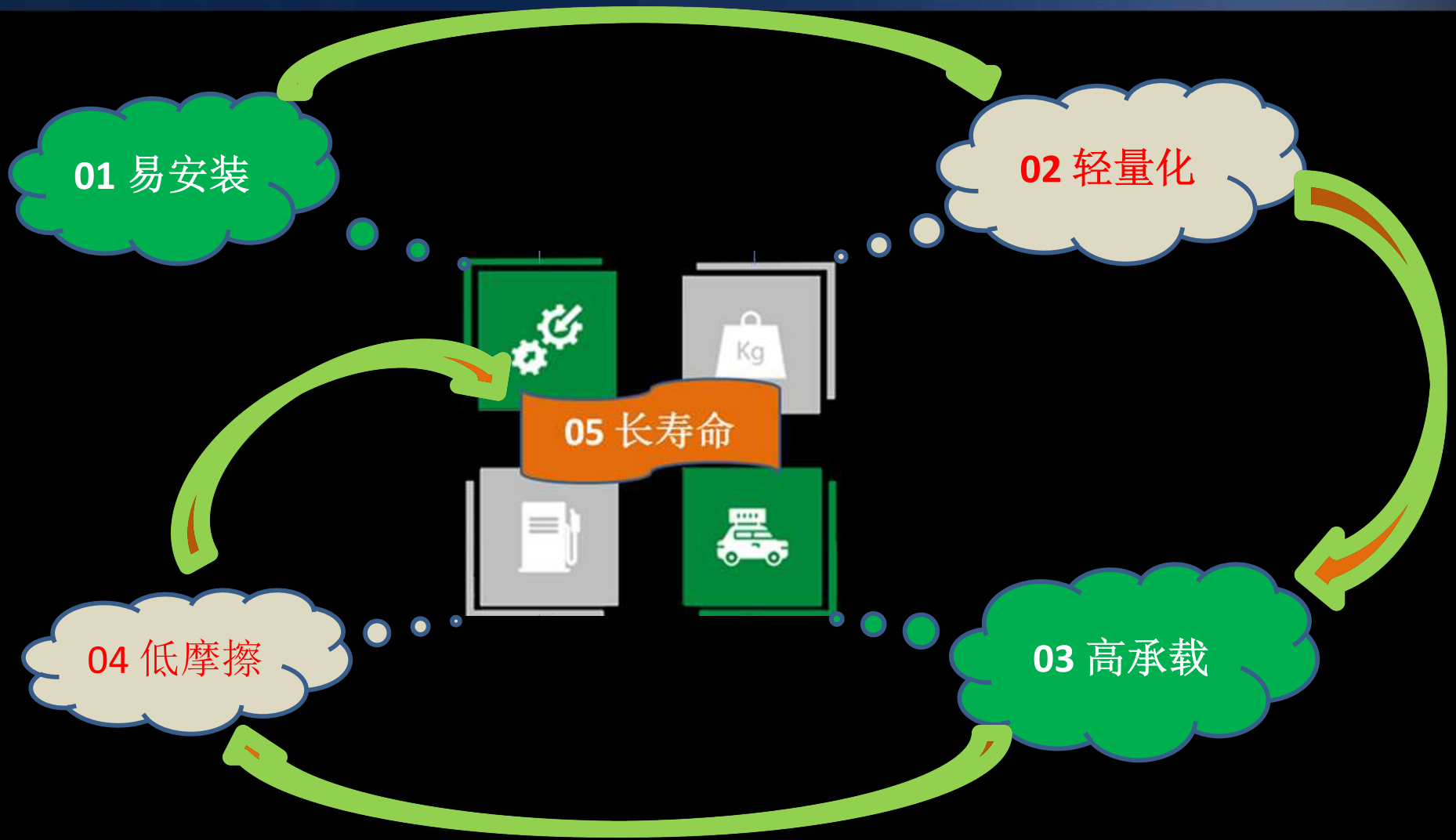

HJD10R08P

01 易安装

- 1、轮端为整体轮端，免维护、预封装，整体拆，整体安装！
- 2、轴头螺母安装只需按规定力矩上紧，不需要回松！
- 3、真正实现轮端傻瓜式保养！

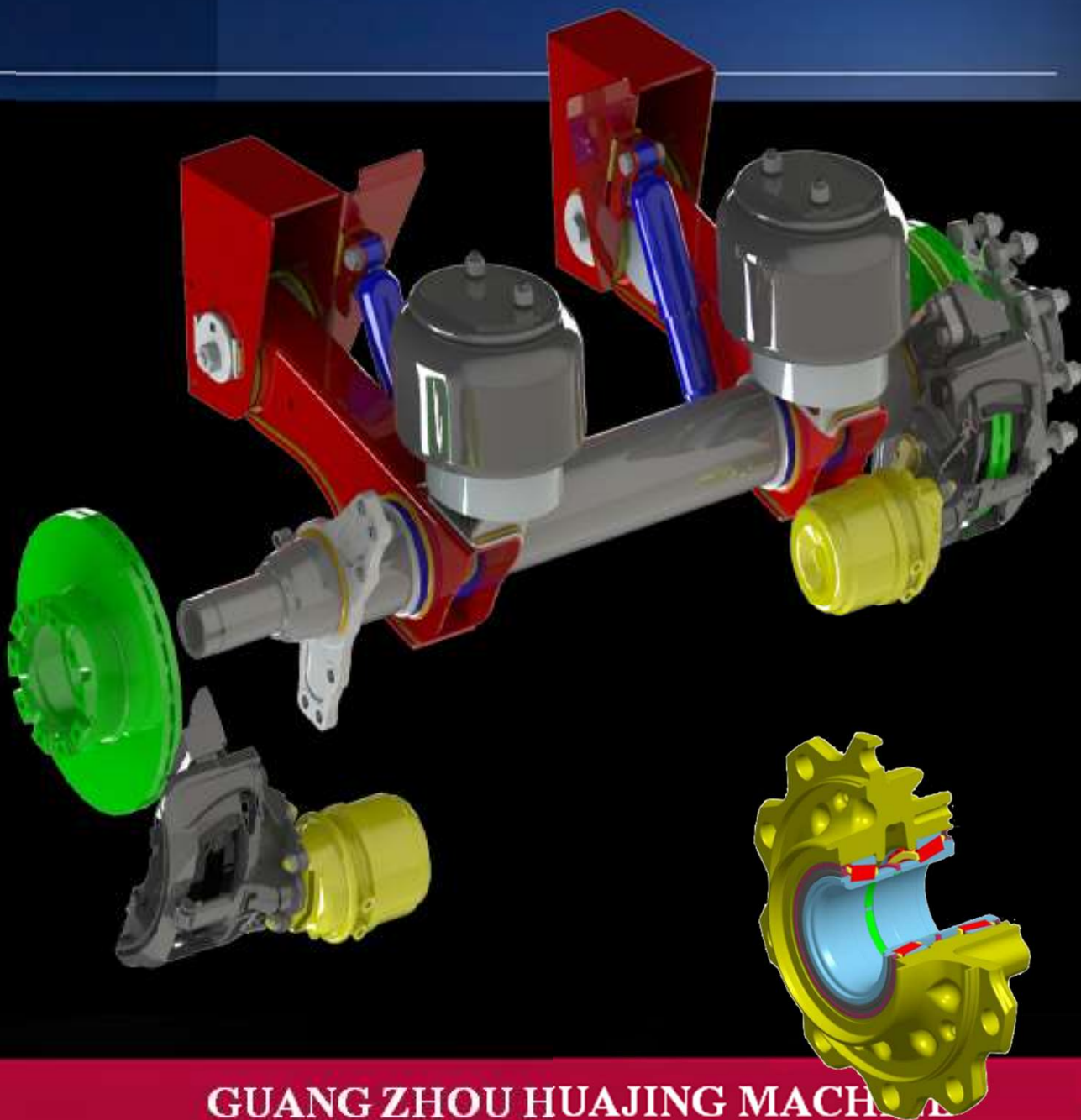

HJD10R08P

02 轻量化

华劲盘刹轮端采用拆入式轴承单元，旋转精度达到P6级，支撑刚度更高，两轴承作用中心距更短，相对应轮毂横向长度变短，大大减少了轮端重量，新轮端19.5KG，旧轮端29.48KG，重量减轻34%。

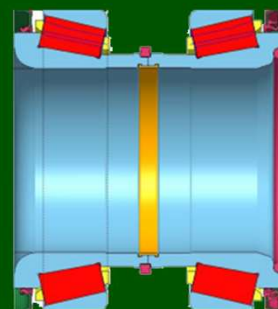

**整条轴重量
295KG!**

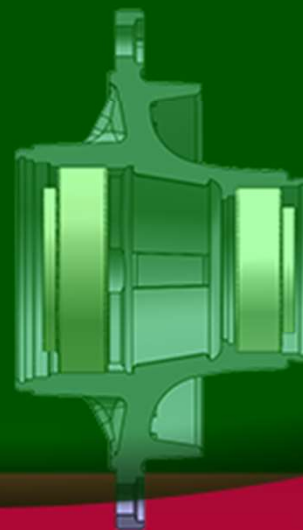

HJD10R08P

03 高承载

华劲车轴采用一体轴设计，行业领先水平工艺生产，使用美标SAE1527无缝钢管温挤成型，具有刚性强、韧性足、高抗扭、抗屈服的特性，加载2.5倍额定载荷疲劳测试200万次无失效！（远远高于国标的80万次）

13吨加载32.5吨



新开发辊道油脂L310

轮端摩擦阻力油脂占9%!

新油脂兼容所有轮端配件，
兼顾润滑与防护功能!

比常规润滑油减少磨损30%!
已申请专利!

HJD10R08P



最大微动磨损深度[μm]

运输模拟实验(-20°C)

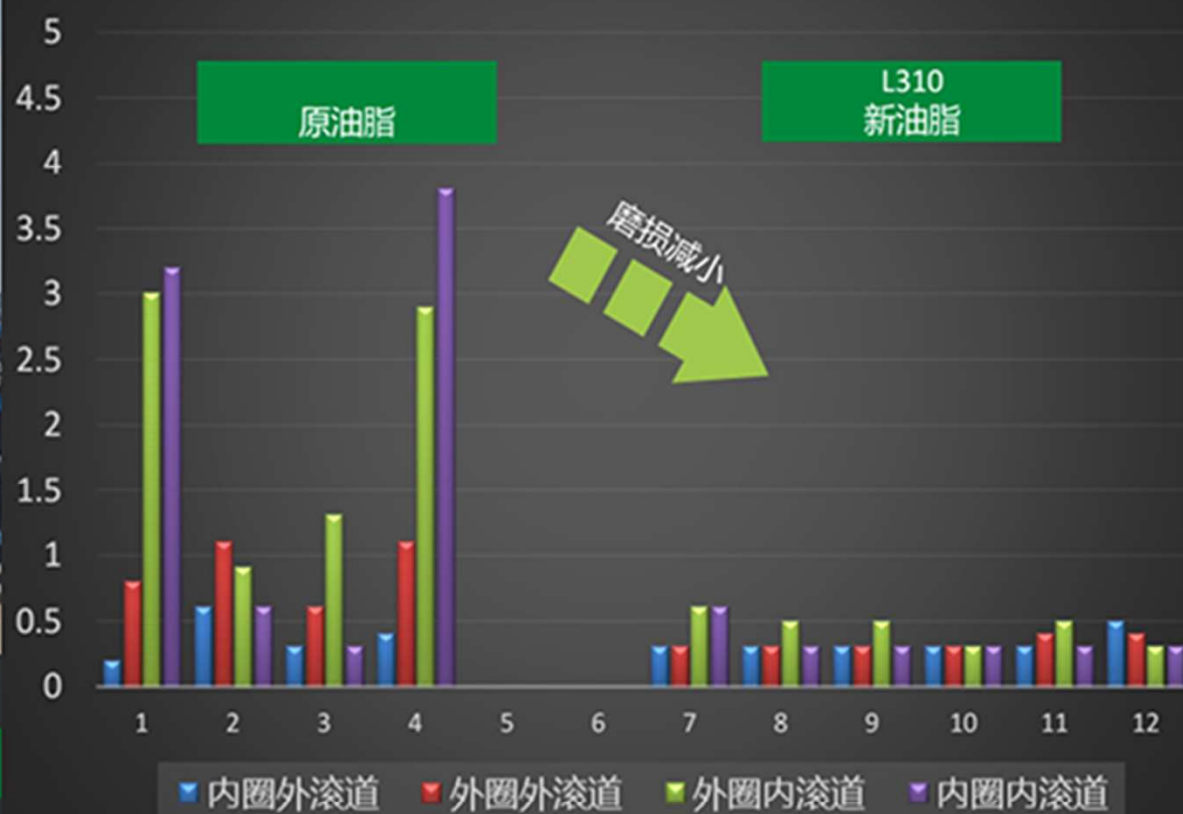

HJD10R08P

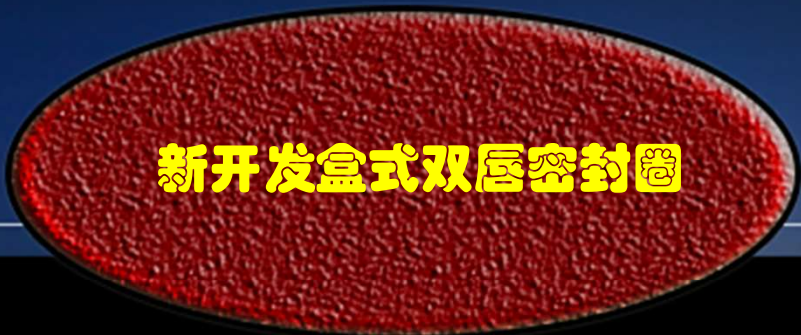

新开发盒式双唇密封圈

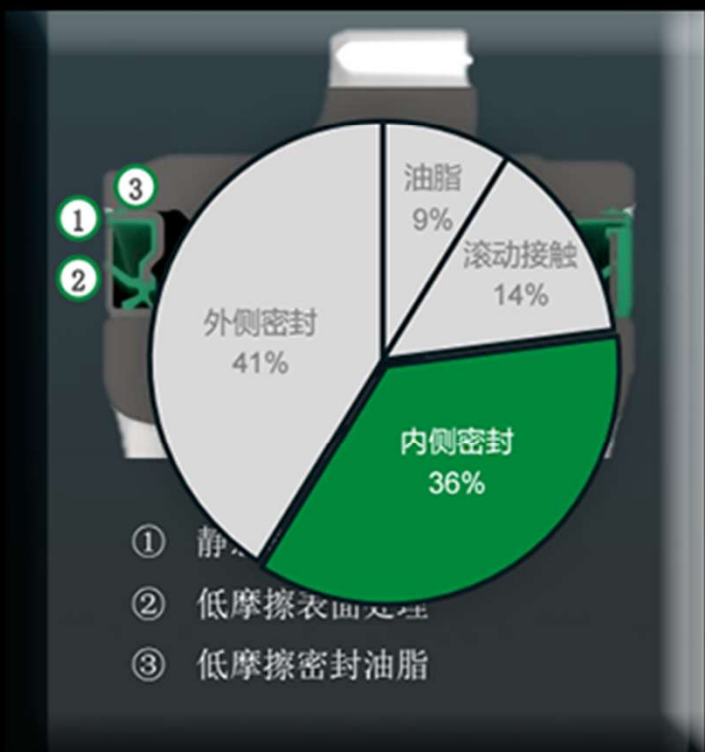

HJD10R08P

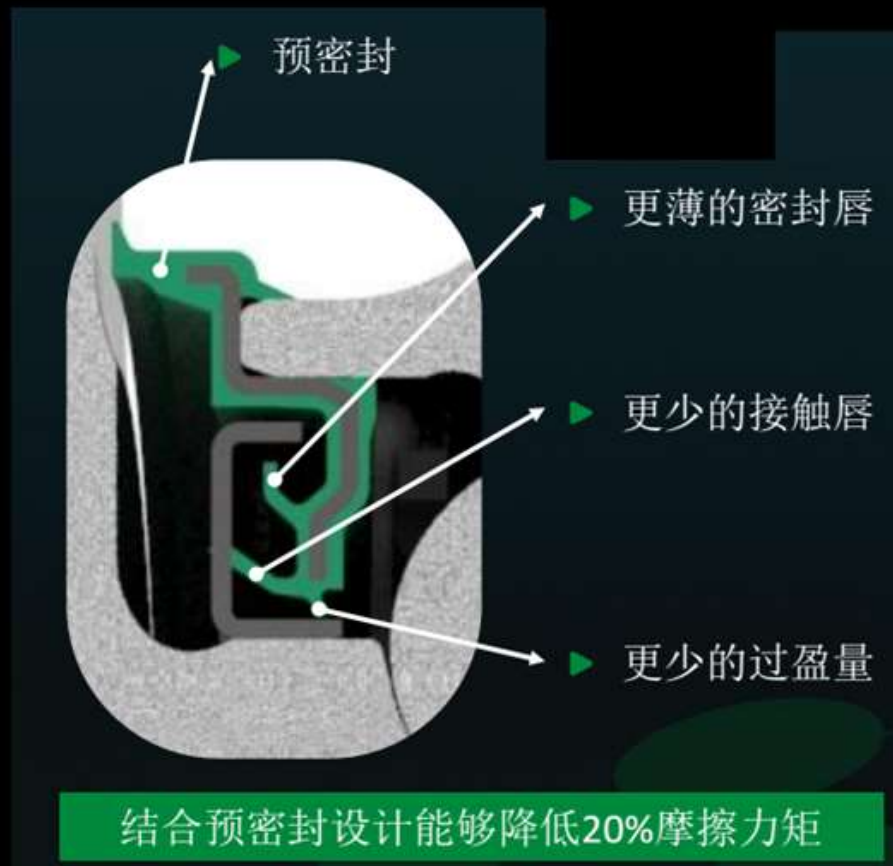

HJD10R08P

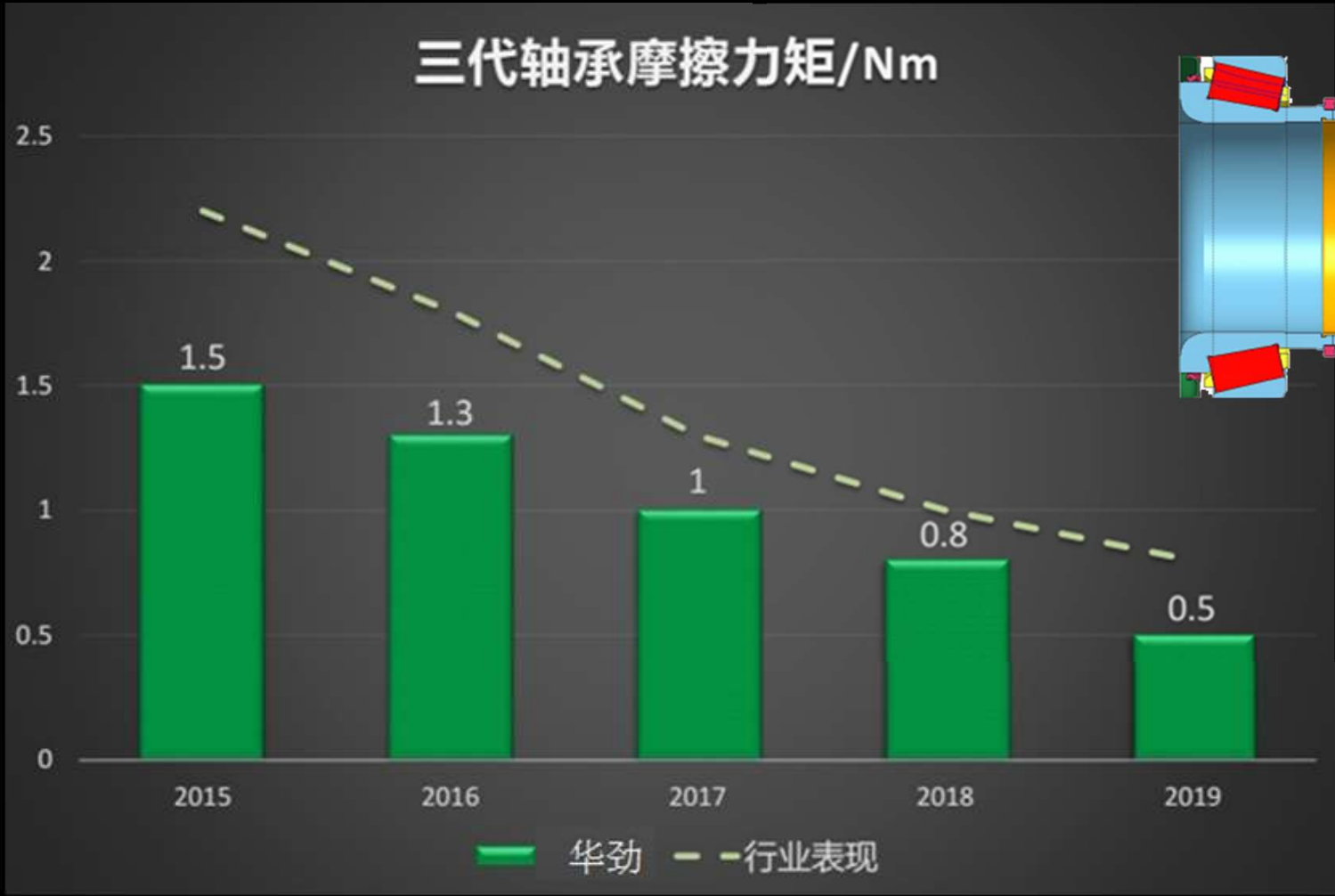
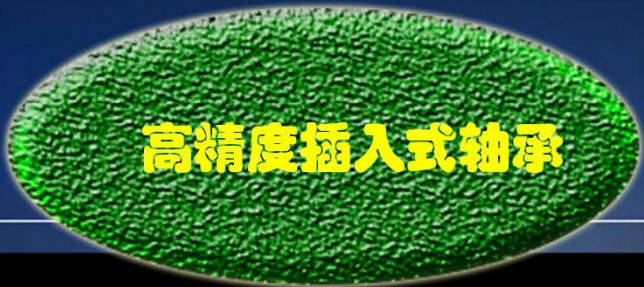

HJD10R08P

能量损耗/Wh

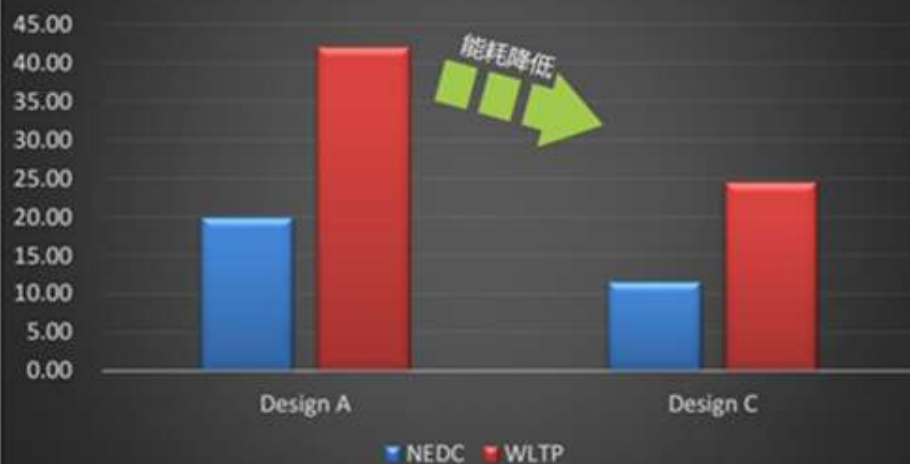

整车燃油消耗降低 1L/100Km

CO₂ 排放/g

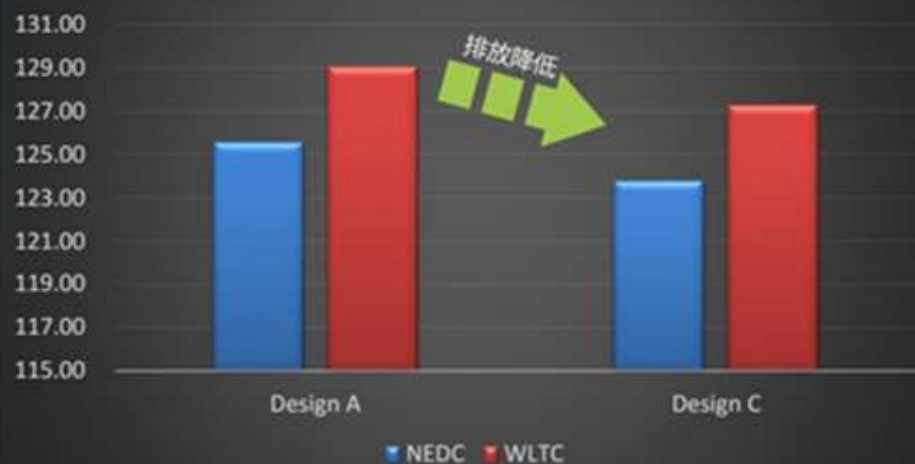

整车CO₂ 排放降低 1.8g/Km

以上低摩擦设计大大提高燃油经济性，按一年20万公里计算，可节油2000升汽油，

**节约运营成本
1.4万元!**

HJD10R08P

05 长寿命

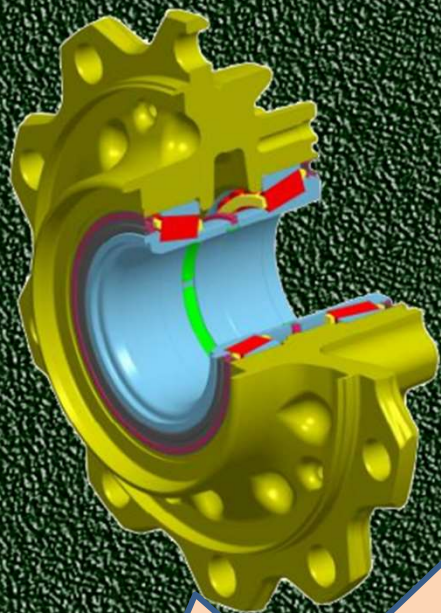

**轮端50万公里免
维护!**

高合金刹车盘，添加钼等
稀有元素，防龟裂，抗变形!

化学元素	C	Si	Mn	P
含量	3.4-3.6	1.9-2.1	0.6-0.8	≤0.05
化学元素	S	Cr	Cu	Mo
含量	0.03-0.07	0.2-0.3	0.2-0.4	0.3-0.5

