

T5 Series

T5-500 to T5-1900

ULTRA HIGH-FORCE, COMPACT DESIGN, NITROGEN GAS SPRINGS



HYSON
METAL FORMING SOLUTIONS™

GENUINELY HYSON

Since 1964, HYSON has been dedicated to providing safer and more reliable products with worldwide support and service. We are continually at the forefront of innovative product design, and engineer forward-thinking features into our self-contained springs, which enable our customers to provide safer working environments.

Our nitrogen gas springs, which comply with all major industry standards, are designed to reduce the risk of tool damage and injuries and include at least one of the following safety features:



Overstroke Protection:

In the event of an overstroke, the HYSON cylinder is designed to fail-safe and release pressure in a predefined manner with deformation or knockout plug.



Overpressure Protection:

Designed to vent excessive gas in the event that the spring becomes overpressured, deformation of the safety lip guide or separation of disc will occur.



Overload Protection:

The piston rod is designed for controlled gas venting between the seal and the piston rod with a specially designed guide and fundamental safety stop in the event of an overload caused by a jammed tool, part or rod side-load.



Additionally, the majority of HYSON springs are **PED** (Pressure Equipment Directive) approved to withstand a minimum of 2 million full cycles according to PED (2014/68/EU). Many of our competitors are in compliance of PED, but compliance is unequal to the 2 million cycle test and approval that HYSON gas springs have undergone. This is one more assurance that with HYSON Nitrogen Gas Springs, you receive an added value of reliability and operational excellence.

GENUINELY HYSON SAFETY APP

Created to enable safer working environments and fight against unsafe counterfeit springs in manufacturing facilities around the globe, the Genuinely HYSON Safety App authenticates nitrogen gas springs with HYSON labeling have the design and safety features customers have come to expect with the HYSON brand. The app is available for download at www.HysonSolutions.com.



**IDEAL FOR AUTOMOTIVE & ELECTRONIC APPLICATIONS
WHERE SPACE IS LIMITED AND HIGH FORCE IS REQUIRED**

Table of Contents

Page

PED - Pressure Equipment Directive..... 2

Product Value 2

Product Features 2

Advanced Safety Features 2

ISO: 9001:2008 Certification 2

Product Specifications 3

Ordering Instructions 3

Mounting Options 3

Stroke per Minute (SPM) vs. Stroke Length 4

T5-500 5

T5-1000 6

T5-1900 7

SPT5 Adapter Plates 8



General Information

HYSON Metal Forming Solutions, headquartered in Brecksville, Ohio, is a world class engineering and manufacturing company that provides high-quality, safety-engineered force and motion control solutions for a wide range of applications and industries, including automotive, aerospace, appliance, medical and HVAC. HYSON partners with our customers to understand applications and provide the best solutions for each one. We are a full service force and motion control provider for critical machine, vehicle and precision metal processing applications, meaning we supply dependent upon each customer’s needs, including: gas springs, cam systems, cushions, manifolds and knockout systems.

Our success lies with our commitment to continually improve ourselves, our processes and our products to ensure we meet or exceed our customers’ expectations. Our ISO-9001, AS-9000 and PED certifications attest to our ongoing commitment to the highest standards of quality.

PED - Pressure Equipment Directive

HYSON gas springs are designed to meet customer expectations for reliability, safety and service lifetime. The design, manufacture and testing of HYSON gas springs has been approved according to the European Pressure Equipment Directive (2014/68/EU).



The Pressure Equipment Directive (PED) replaces all previous European legislation governing the design, manufacture and testing of pressure vessels.

Product Value

- Ideal for applications where space is limited
- Highest force per area of any gas spring on market

Product Features

- Three models with contact forces from 5100 to 19,200 N / 1,150 to 4,320 lbf
- Stroke lengths to 80 mm / 3.15 in
- Variety of mounting options available
- Flexible guide absorbs lateral movement and misalignments in the die

Advanced Safety Features

- Guide features built-in pressure relief if assembled upside down
- Secondary piston retaining ring for extra protection
- Overload, Overstroke and Overpressure protection vents internal gas pressure in a controlled manner

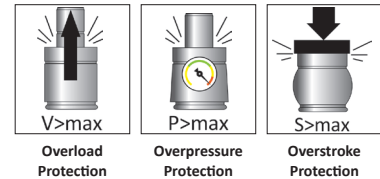

ISO: 9001:2008
CERTIFICATION



ISO: 9001:2008 CERTIFICATION

Focused on meeting customer expectations, ISO 9001 is an internationally recognized standard for quality management with certificates issued to organizations in 178 countries. This highly regarded certification reflects HYSON's ongoing commitment to deliver solutions that meet the highest quality standards.

All dimensions are in millimeters unless otherwise noted.

Product Specifications

Pressure Medium	Nitrogen
Max. Charging Pressure	200 bar/2900 psi
Min. Charging Pressure	25 bar/365 psi
Operating Temperature.....	0° to 80°C/32° to 176°F
Force Increase by Temperature.....	±0.3% per °C/±0.009% per °F
Recommended Max. Strokes/Min.....	~70 to 200 @ 20°C
Max. Piston Rod Velocity.....	1.6 m/s / 315 ft./min.
Charge Fitting	Two pieces: T2-770-T3 adapter 4026164

ORDERING INSTRUCTIONS

T5-XXXX

X

38

MODEL

T5-500, T5-1000, T5-1900

STROKE (mm)

See Dimensional Information Charts

The recommendation is to not use the last 5mm or 10% of the nominal stroke length.
See page 8 for T5 Side Port Adapter Plate Order Instructions.

MOUNTING OPTIONS

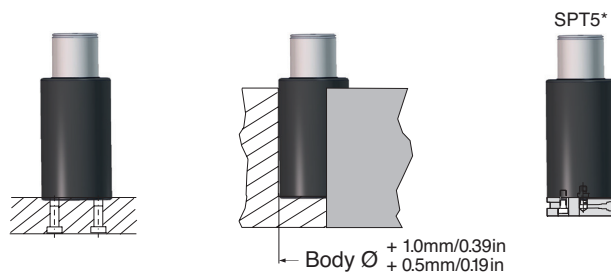

An external stop for the tool is recommended to prevent overstroke in the springs.
*See page 8 for more information.

All dimensions are in millimeters unless otherwise noted.

Stroke per Minute (SPM) vs. Stroke Length

The information in the diagram is based on calculations made for T5 gas springs operating at a 200 bar/2900 psi charge pressure in a well-ventilated area with an ambient temperature of 20°C/68°F.

T5-500

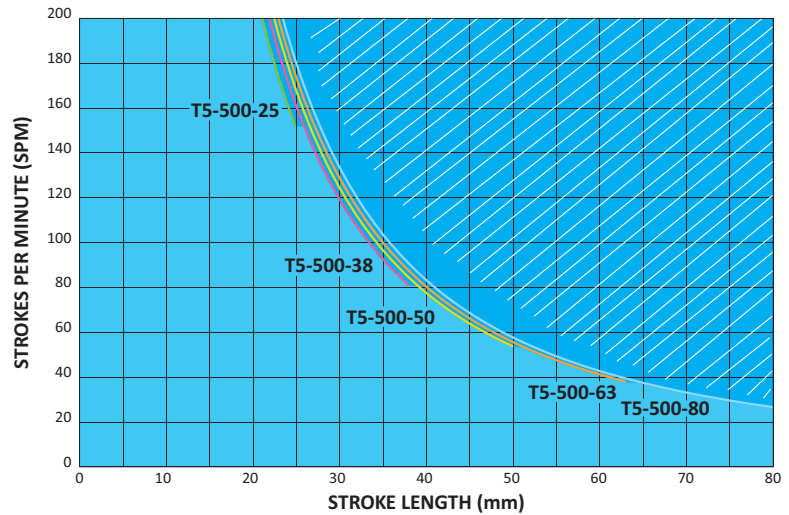

T5-1000

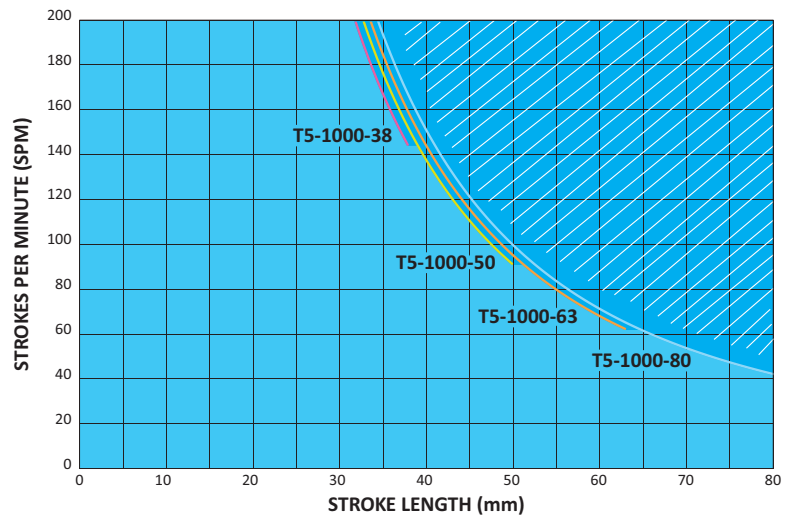

T5-1900

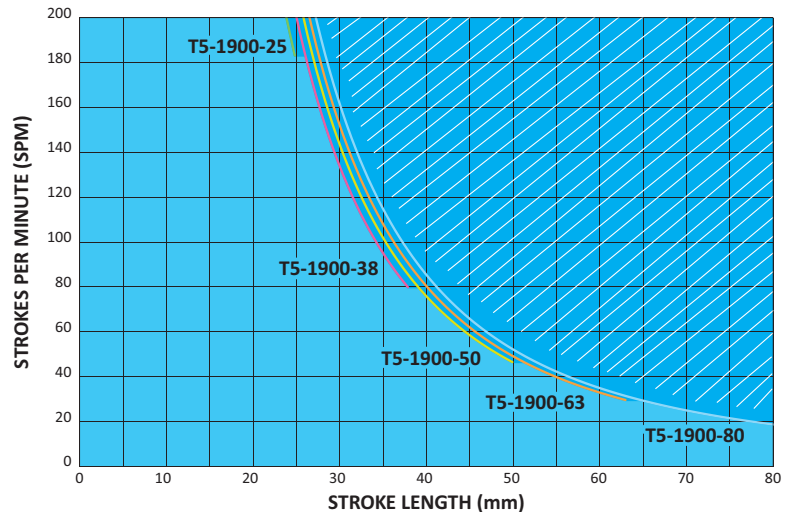

Advanced Safety Features



V > max
Overload Protection

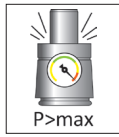

P > max
Overpressure Protection

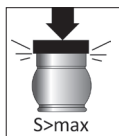

S > max
Overstroke Protection

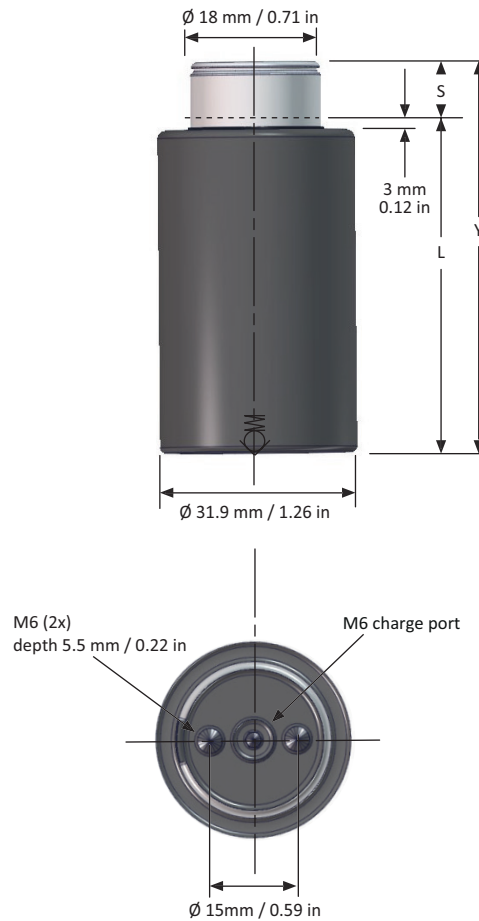

T5-500 Dimensional Information

Order Number (model x stroke)	Stroke S		Contact Force**		Full Stroke Force**		Cylinder Height		Body Height		Gas Volume ℓ	Weight kg
	mm	in	N	lbf.	N	lbf.	Y ±0.25 mm	Y ±0.010 in	L mm	L in		
Preferred Stroke Lengths (optimal delivery)												
T5-500x10	10	0.39	5,100	1,150	6,600	1,490	75	2.95	65	2.56	0.01	0.27
T5-500x15	15	0.59			7,100	1,610	85	3.35	70	2.76	0.02	0.29
T5-500x25	25	0.98			7,900	1,780	105	4.13	80	3.15	0.02	0.33
T5-500x38	38*	1.50			8,700	1,960	130	5.12	92	3.62	0.03	0.37
T5-500x50	50*	1.97			9,100	2,040	155	6.10	105	4.13	0.04	0.42
T5-500x63	63*	2.48			8,800	1,990	190	7.48	127	5.00	0.05	0.50
T5-500x80	80*	3.15			9,200	2,060	225	8.86	145	5.71	0.06	0.56

NOTE:
*For stroke lengths over 25mm / 0.98in, the spring should be attached to the tool using the threaded holes in the bottom.
**At full charge

All dimensions are nominal. Data shown are typical. Actual data for any particular unit may vary.

Advanced Safety Features



V>max
Overload Protection



P>max
Overpressure Protection

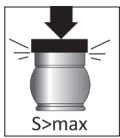

S>max
Overstroke Protection

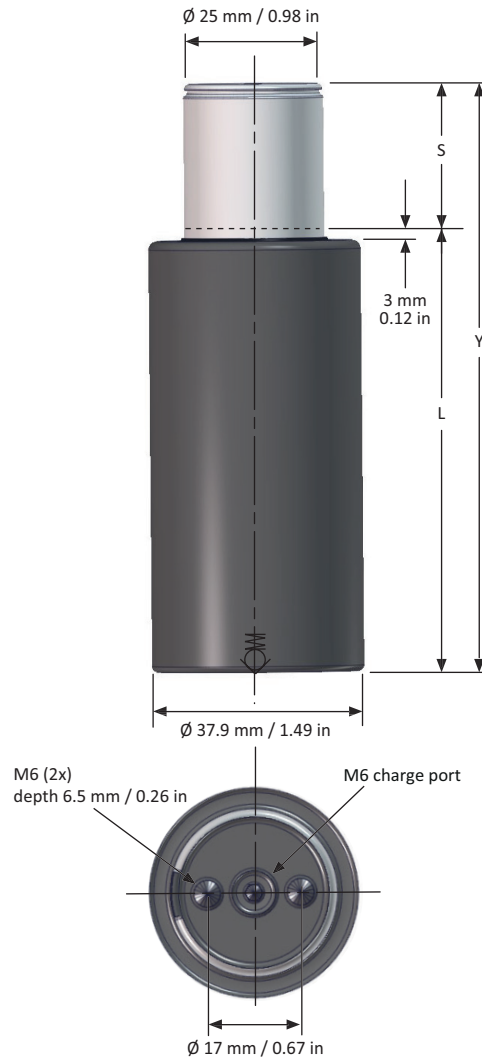

T5-1000 Dimensional Information

Order Number (model x stroke)	Stroke S		Contact Force**		Full Stroke Force**		Cylinder Height		Body Height		Gas Volume ℓ	Weight kg
	mm	in	N	lbf.	N	lbf.	Y ±0.25	Y ±0.010	L	L		
							mm	in	mm	in		
Preferred Stroke Lengths (optimal delivery)												
T5-1000x10	10	0.39	9,800	2,200	13,300	2,980	75	2.95	65	2.56	0.03	0.36
T5-1000x15	15	0.59			14,400	3,240	85	3.35	70	2.75	0.03	0.39
T5-1000x25	25	0.98			16,100	3,620	105	4.13	80	3.15	0.04	0.43
T5-1000x38	38*	1.50			16,900	3,800	135	5.31	97	3.82	0.06	0.50
T5-1000x50	50*	1.97			17,700	3,990	160	6.30	110	4.33	0.07	0.56
T5-1000x63	63*	2.48			16,500	3,710	205	8.07	142	5.60	0.10	0.67
T5-1000x80	80*	3.15			17,300	3,880	240	9.44	160	6.30	0.12	0.75

NOTE:

*For stroke lengths over 25mm / 0.98in, the spring should be attached to the tool using the threaded holes in the bottom.

**At full charge

All dimensions are nominal. Data shown are typical. Actual data for any particular unit may vary.

Advanced Safety Features



Overload Protection

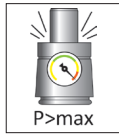

Overpressure Protection

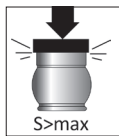

Overstroke Protection

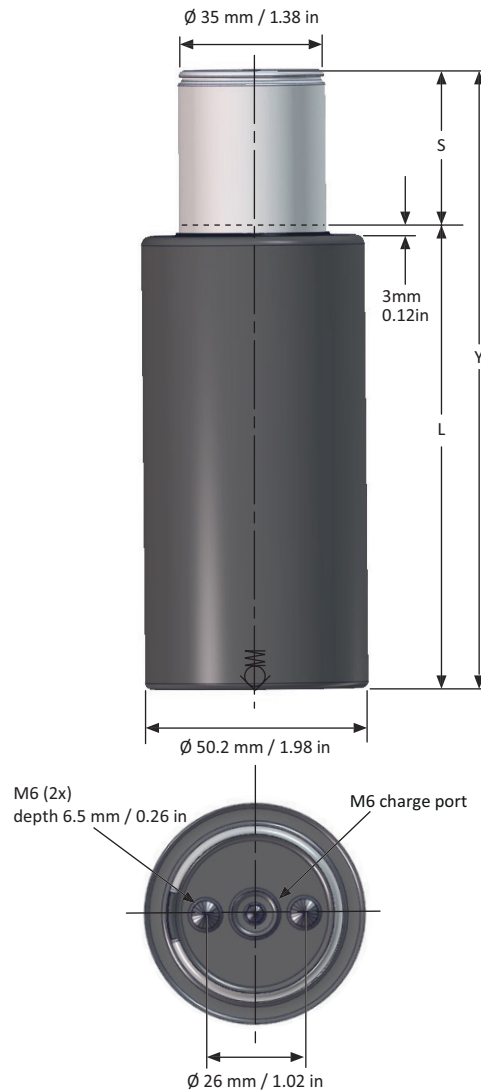

T5-1900 Dimensional Information

Order Number (model x stroke)	Stroke S		Contact Force**		Full Stroke Force**		Cylinder Height		Body Height		Gas Volume ℓ	Weight kg
	mm	in	N	lbf.	N	lbf.	Y ±0.25 mm	Y ±0.010 in	L mm	L in		
Preferred Stroke Lengths (optimal delivery)												
T5-1900x10	10	0.39	19,200	4,320	26,300	5,920	80	3.15	70	2.76	0.05	0.69
T5-1900x15	15	0.59			31,800	7,140	95	3.74	80	3.15	0.05	0.76
T5-1900x25	25	0.98			30,900	6,950	115	4.53	90	3.54	0.08	0.84
T5-1900x38	38*	1.50			31,900	7,160	150	5.91	112	4.41	0.12	0.98
T5-1900x50	50*	1.97			33,800	7,600	175	6.89	125	4.92	0.14	1.08
T5-1900x63	63*	2.48			34,800	7,820	205	8.07	142	5.59	0.17	1.21
T5-1900x80	80*	3.15			35,600	8,000	245	9.65	165	6.50	0.21	1.37

NOTE:

*For stroke lengths over 25mm / 0.98in, the spring should be attached to the tool using the threaded holes in the bottom.

**At full charge

All dimensions are nominal. Data shown are typical. Actual data for any particular unit may vary.

SPT5 ADAPTER PLATES

To utilize T5 gas spring series in hoses systems, HYSON offers side port adapter plate SPT5. SPT5 is available as an add-on or pre-assembled solution.

ORDERING OPTIONS

ADD-ON

SPT5-XXXX
MODEL
 SPT5-500, SPT5-1000, SPT5-1900



PRE-ASSEMBLED

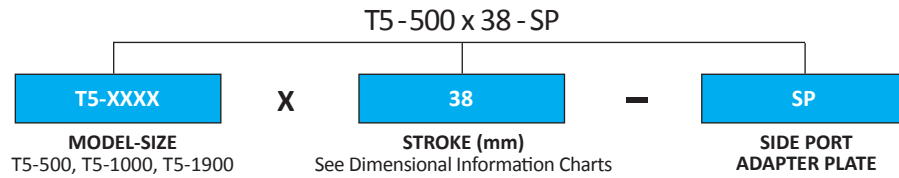

SPT5-500 can only be used in hoses systems due to lack of valve, however SPT5-1000 and SPT5-1900 can operate in both hoses systems and as self contained solutions. For use in hoses systems, we recommend using our Micro EO24™ hose system in combination with our high-pressure control block (4717241).

SPT5-500

Note!
SPT5-500 must be used in hoses systems only due to lack of valve.

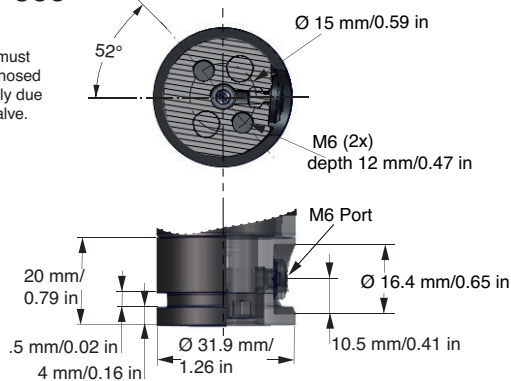

For model	Order No.	For U-groove mounts on SPT5
T5-500	SPT5-500	U-groove mount is equal to T3-350

To foot mount T5 gas spring series when using SPT5 side port adapter plate, use FFC flange:

- * SPT5-500 use FFC - 350
- * SPT5-1000 use FFC - 250
- * SPT5-1900 use FFC - 750

SPT5-1000

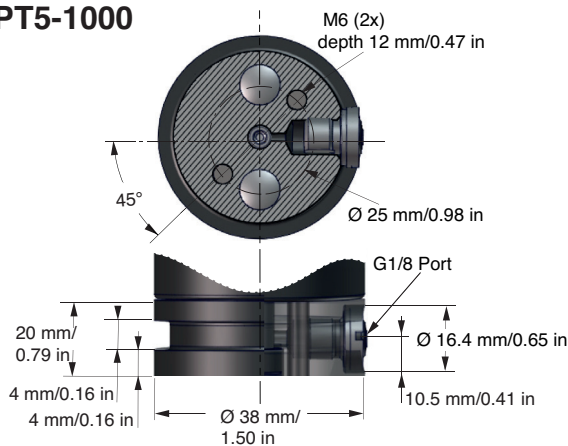

For model	Order No.	For U-groove mounts on SPT5
T5 1000	SPT5-1000	U-groove mount is equal to T3- 500

SPT5-1900

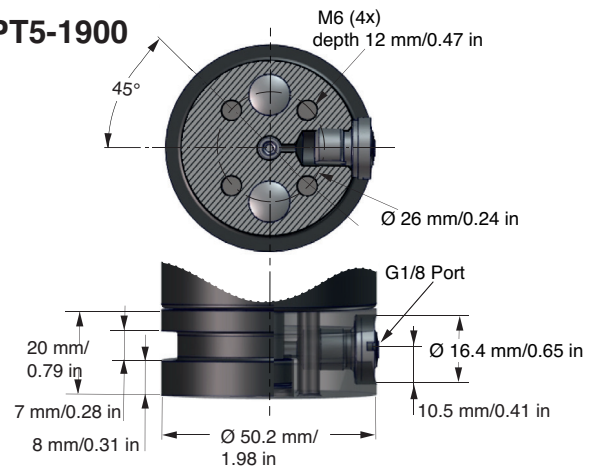

For model	Order No.	For U-groove mounts on SPT5
T5 1900	SPT5-1900	U-groove mount is equal to T3-1000



HYSON
METAL FORMING SOLUTIONS™

www.HysonSolutions.com
E-mail: Orders@HysonSolutions.com

U.S.A. Headquarters • 10367 Brecksville Road • Brecksville, OH 44141 USA • Tel: 800-876-4976, 440-526-5900

©HYSON 2017
T5 1K 10/17