



## **10.4 inch TFT Display Series**

**GDTL104XL-S03**

Dalian Good Display Co., Ltd.



- Tentative Specification
- Preliminary Specification
- Approval Specification

# MODEL NAME: GDTL104XL-S03

## Version:C 1

<b>Customer: Common</b>	
<b>APPROVED BY</b>	<b>SIGNATURE</b>
<b>Name / Title</b> _____	_____
Note	
_____	
Please return 1 copy for your confirmation with your signature and comments.	

Approved By	Checked By	Prepared By
		

**CONTENTS**

<b>1. GENERAL DESCRIPTION.....</b>	<b>4</b>
1.1 OVERVIEW.....	4
1.2 FEATURES.....	4
1.3 APPLICATION.....	4
1.4 GENERAL SPECIFICATI0NS.....	4
1.5 MECHANICAL SPECIFICATIONS.....	4
<b>2. ABSOLUTE MAXIMUM RATINGS.....</b>	<b>5</b>
2.1 ABSOLUTE RATINGS OF ENVIRONMENT.....	5
2.2 ELECTRICAL ABSOLUTE RATINGS.....	6
2.2.1 TFT LCD MODULE.....	6
2.2.2 LED CONVERTER.....	6
<b>3. ELECTRICAL CHARACTERISTICS.....</b>	<b>7</b>
3.1 TFT LCD MODULE.....	8
3.2 LED CONVERTER.....	9
<b>4. BLOCK DIAGRAM.....</b>	<b>10</b>
4.1 TFT LCD MODULE.....	10
<b>5. INTERFACE PIN ASIGNMENT.....</b>	<b>11</b>
5.1 TFT LCD MODULE.....	11
5.2 BACKLIGHT UNIT (Converter connector pin).....	12
5.3 COLOR DATA INPUT ASSIGNMENT.....	13
<b>6. INTERFACE TIMING.....</b>	<b>14</b>
6.1 INPUT SIGNAL TIMING SPECIFICATIONS.....	14
6.2 POWER ON/OFF SEQUENCE.....	15
6.3 THE INPUT DATA FORMAT.....	16
6.4 SCANNING DIRECTION.....	17
<b>7. OPTICAL CHARACTERISTICS.....</b>	<b>18</b>
7.1 TEST CONDITIONS.....	19
7.2 OPTICAL SPECIFICATIONS.....	21
<b>8. RELIABILITY TEST CRITERIA.....</b>	<b>22</b>
<b>9. DEFINITION OF LABELS.....</b>	<b>23</b>
<b>10. MECHANICAL CHARACTERISTICS.....</b>	<b>24</b>
<b>11. PACKAGING.....</b>	<b>25</b>
<b>12. PRECAUTIONS.....</b>	<b>26</b>
12.1 ASSEMBLY AND HANDLING PRECAUTIONS.....	26
12.2 SAFETY PRECAUTIONS.....	26

**REVISION HISTORY**

Version	Date	Page	Description
1.0	2020.12.12	ALL	First issue
1.1	2020.12.16	25	Added packing drawing

GOODDISPLAY

## 1. GENERAL DESCRIPTION

### 1.1 OVERVIEW

GDTL104XL-S03 is a 10.4" TFT Liquid Crystal Display module with LED backlight unit and 30-pin-and LVDS interface. This product supports 1024 x 768 XGA format and can display true 16.7M colors (6-bits colors with FRC). The converter module for LED backlight is built-in.

### 1.2 FEATURES

- Excellent brightness (1000 nits)
- Ultra high contrast ratio (1000:1)
- Fast response time (Ton+Toff average 25 ms)
- XGA (1024 x 768 pixels) resolution
- DE (Data Enable) only mode
- LVDS (Low Voltage Differential Signaling) interface
- Ultra wide viewing angle: 176(H)/ 176(V) (CR>10) Super MVA technology
- 180 degree rotation display option
- Color reproduction (Nature color)
- Wide operation and storage temperature range

### 1.3 APPLICATION

- TFT LCD monitor for Industrial applications
- Slim design display for portable applications
- Digitizer Applicable Design

### 1.4 GENERAL SPECIFICATIONS

Item	Specification	Unit	Note
Active Area	210.43 (H) x 157.82 (V) (10.4" diagonal)	mm	(1)
Bezel Opening Area	215.4 (H) x 161.8 (V)	mm	
Driver Element	a-si TFT active matrix	-	-
Pixel Number	1024 x R.G.B. x 768	pixel	-
Pixel Pitch (HxV)	0.2055 (H) x 0.2055 (V)	mm	-
Pixel Arrangement	RGB vertical stripe	-	-
Display Colors	16.7 M	color	-
Display Operation Mode	Normally black / VA	-	-
Surface Treatment	Anti Glare	-	-
Total power consumption(typ)	7.7	W	typ

Note (1)Please refer to the attached drawings for more information of front and back outline dimensions.

### 1.5 MECHANICAL SPECIFICATIONS

Item		Min.	Typ.	Max.	Unit	Note
Module Size	Horizontal (H)	238.1	238.6	239.1	mm	(1)
	Vertical (V)	175.3	175.8	176.3	mm	
	Depth (D)	-	7.47	-	mm	-
Weight		-	290	-	g	-

Note (1)Please refer to the attached drawings for more information of front and back outline dimensions.

Note (2) Measurement should be done by pressing down the PCBA.

**2. ABSOLUTE MAXIMUM RATINGS**

**2.1 ABSOLUTE RATINGS OF ENVIRONMENT**

Item	Symbol	Value		Unit	Note
		Min.	Max.		
Operating Ambient Temperature	T <sub>OP</sub>	-30	+80	°C	
Storage Temperature	T <sub>ST</sub>	-30	+80	°C	

Note (1) Temperature and relative humidity range is shown in the figure below.

- (a) 90 %RH Max. (Ta < 40 °C).
- (b) Wet-bulb temperature should be 39 °C Max. (Ta > 40 °C).
- (c) No condensation

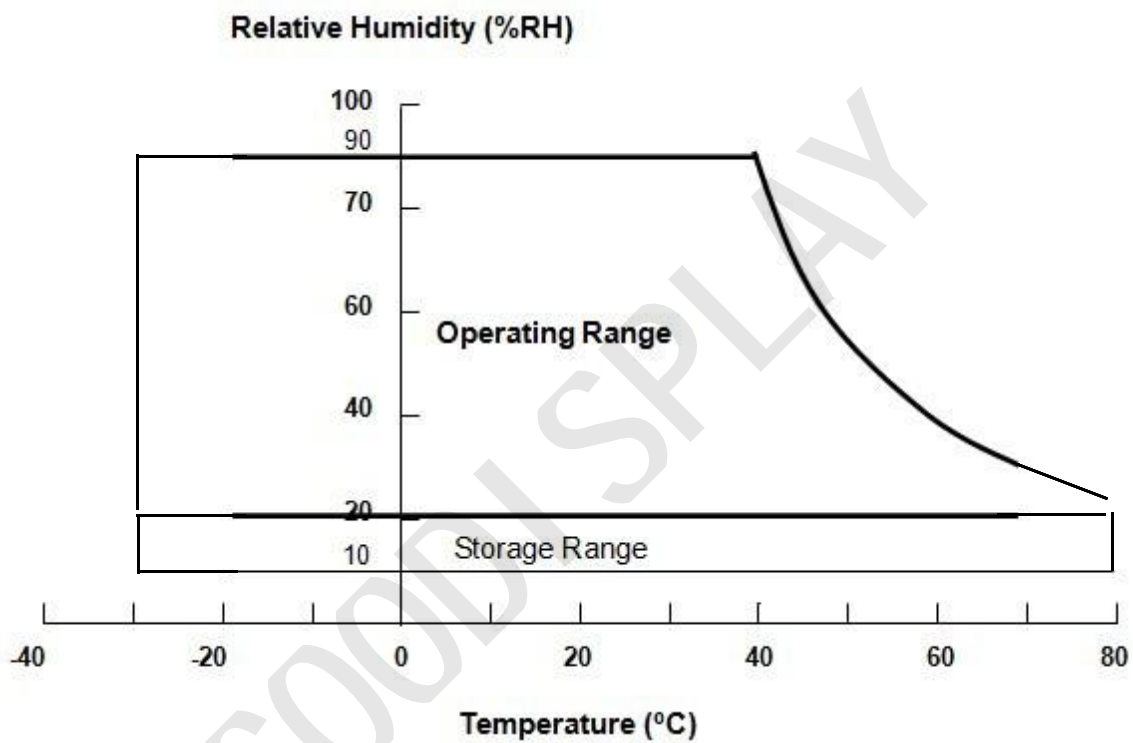

## 2.2 ELECTRICAL ABSOLUTE RATINGS

### 2.2.1 TFT LCD MODULE

Item	Symbol	Value		Unit	Note
		Min.	Max.		
Power Supply Voltage	VCC	-0.3	4	V	(1)

### 2.2.2 LED CONVERTER

Item	Symbol	Value		Unit	Note
		Min.	Max.		
Converter Voltage	$V_i$	-0.3	18	V	(1), (2)
Enable Voltage	EN	-0.3	5.5	V	
Backlight Adjust	ADJ	-0.3	5.5	V	

Note (1) Permanent damage to the device may occur if maximum values are exceeded. Function operation should be restricted to the conditions described under Normal Operating Conditions.

Note (2) Specified values are for LED light bar (Refer to 3.2 for further information).

**3. ELECTRICAL CHARACTERISTICS**

**3.1 TFT LCD MODULE**

Ta = 25 ± 2 °C

Parameter	Symbol	Value			Unit	Note
		Min.	Typ.	Max.		
Power Supply Voltage	V <sub>CC</sub>	3.0	3.3	3.6	V	(1)
Rush Current	I <sub>RUSH</sub>	-	-	4.0	A	(2)
Power Supply Current	White	-	660	790	mA	(3)
	Black	-	500	600	mA	
Power Consumption	P <sub>L</sub>	---	2.2	2.6	W	
LVDS differential input voltage	VID	100	-	600	mV	-
LVDS common input voltage	V <sub>ICM</sub>	0.7	-	1.6	V	-

Note (1) The assembly should be always operated within above ranges.

Note (2) Measurement Conditions:

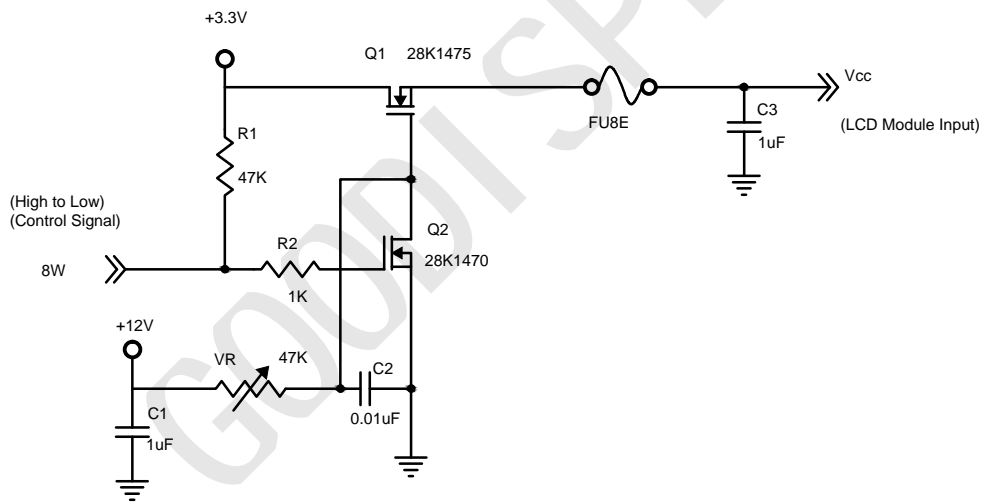



**VCC rising time is 470us**

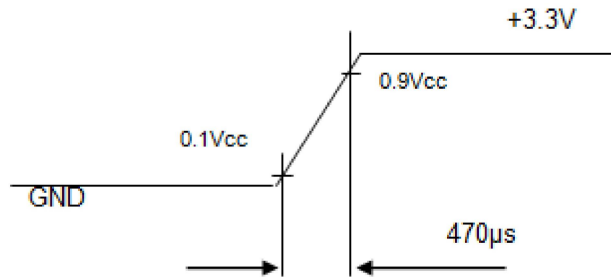

Note (3) The specified power supply current is under the conditions at V<sub>cc</sub> = 3.3 V, T<sub>a</sub> = 25 ± 2 °C, f<sub>v</sub> = 60 Hz, whereas a power dissipation check pattern below is displayed.

a. White Pattern

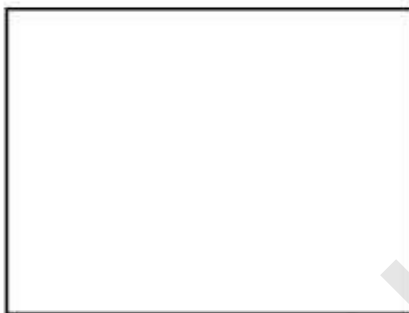

Active Area

b. Black Pattern



Active Area

c. Vertical Stripe Pattern

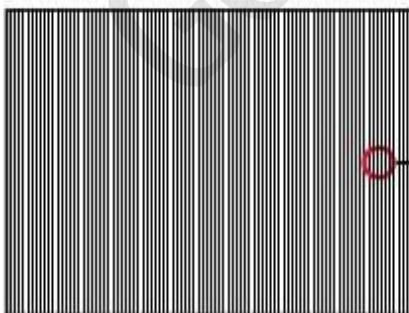

Active Area

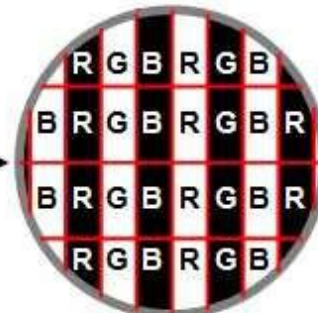

## 3.2 LED CONVERTER

Ta = 25 ± 2 °C

Parameter	Symbol	Value			Unit	Note	
		Min.	Typ.	Max.			
Converter Power Supply Voltage	V <sub>i</sub>	-	12	-	V	(Duty 100%)	
Converter Power Supply Ripple Voltage	V <sub>IRP</sub>			500	mV		
Converter Power Supply Current	I <sub>i</sub>	---	460	580	mA	@ Vi = 12V (Duty 100%)	
Converter Inrush Current	I <sub>IRUSH</sub>			3.0	A	@ Vi rising time = 10ms (Vi =12V)	
LED Power Consumption	P <sub>LED</sub>	---	5.52	---	W	@ Vi = 12V (Duty 100%)	
EN Control Level	Backlight on	BLON	2.5	3.3	5	V	
	Backlight off		0	---	0.3	V	
PWM Control Level	PWM High Level	E_PWM	2.5	3.3	5	V	
	PWM Low Level		0	---	0.15	V	
PWM Noise Range	V <sub>Noise</sub>			0.1	V		
PWM Control Duty Ratio			2	100	%	@200Hz	
PWM Control Frequency	f <sub>PWM</sub>	190	200	20k	Hz	(2)	
LED Life Time	L <sub>L</sub>	30,000	100,000		Hrs	(3)	

Note (1) LED current is measured by utilizing a high frequency current meter as shown below

Note (2) At 190 ~1KHz PWM control frequency, duty ratio range is restricted from 2% to 100%.

1K ~20KHz PWM control frequency · minimum duty on-time ≥ 20 us.

Note (3) The life time of LED is estimated data and defined as the time when it continues to operate under the conditions at Ta = 25 ± 2 °C and I<sub>LED</sub> = 20mA (LED forward current) until the brightness becomes ≤ 50% of its original value. Operating LED under high temperature environment will reduce life time and lead to color shift

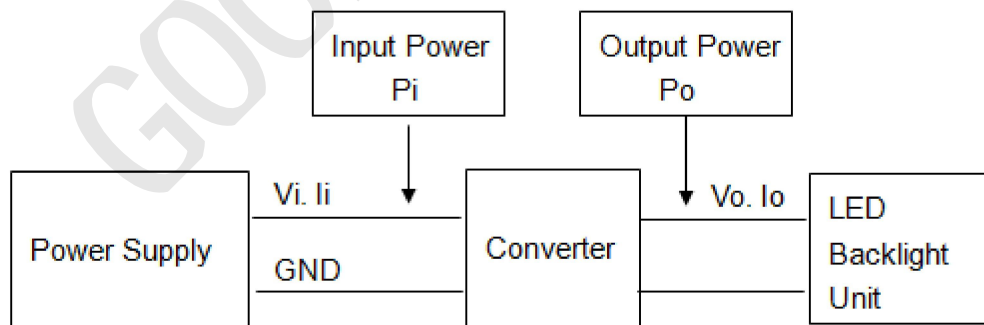

4. BLOCK DIAGRAM

4.1 TFT LCD MODULE

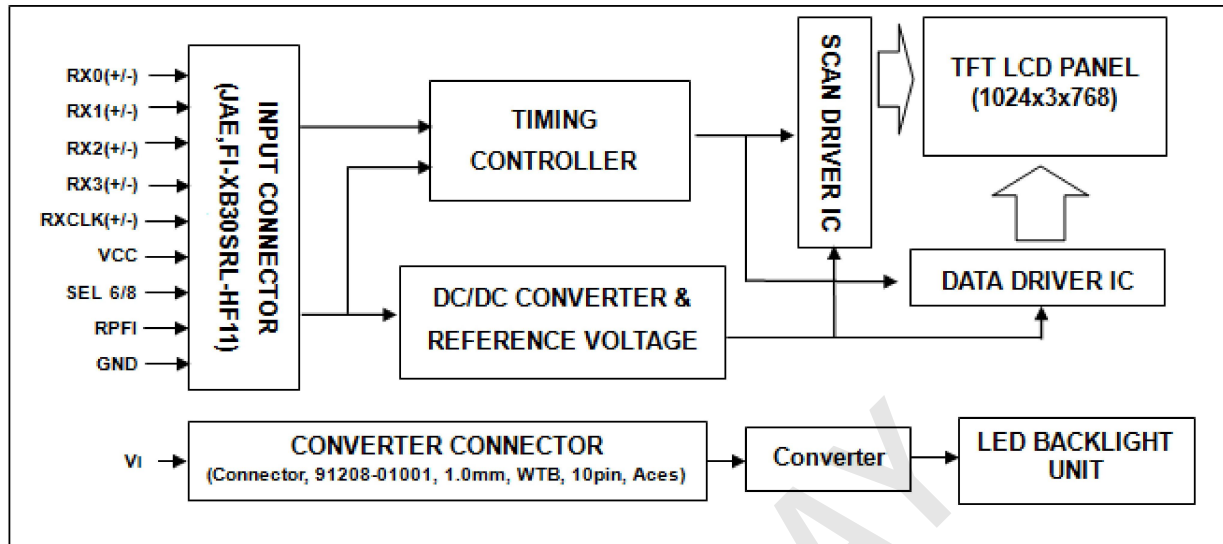

## 5. INTERFACE PIN ASSIGNMENT

### 5.1 TFT LCD MODULE

A 30pin connector of P-two 187098-30091 is used for the module electronics interface.

And a special plug needed for connecting this connector, the recommended model is P-two 187130-30xx or JAE FI-X30H.

No	Symbol	I/O	Function	Remark
1	NC	I	Reserved as BIST function for INX test	1
2	GND	P	Ground	
3	Rin3+	I	Positive LVDS differential data input (+)	
4	Rin3-	I	Negative LVDS differential data input (-)	
5	GND	P	Ground	
6	CLK+	I	Clock signal (+)	
7	CLK-	I	Clock signal (-)	
8	GND	P	Ground	
9	Rin2+	I	Positive LVDS differential data input (+)	
10	Rin2-	I	Negative LVDS differential data input (-)	
11	GND	P	Ground	
12	Rin1+	I	Positive LVDS differential data input (+)	
13	Rin1-	I	Negative LVDS differential data input (-)	
14	GND	P	Ground	
15	Rin0+	I	Positive LVDS differential data input (+)	
16	Rin0-	I	Negative LVDS differential data input (-)	
17	GND	P	Ground	
18	NC	-	No Connection	
19	GND	P	Ground	
20	SEL6/8	I	Selection for 6 bits/8bit LVDS data input Low or NC : 8 bit input mode High : 6 bit input mode	2
21	NC	I	Reversed as EE_WP for OTP function	3
22	NC	I	Reversed as EE_SDA for OTP function	3
23	NC	I	Reversed as EE_SCL for OTP function	3
24	Reverse	I	Reverse panel function (Display rotation)	4

Note (1) Connector Part No.: STM,MSCK2407P30.D or equivalent

Note (2) "Low" stands for 0V. "High" stands for 3.3V. "NC" stands for "No Connected"

No	Symbol	I/O	Function	Remark
25	GND	P	Ground	
26	GND	P	Ground	
27	GND	P	Ground	
28	VDD	P	Power supply: + 3.3V	
29	VDD	P	Power supply: + 3.3V	
30	VDD	P	Power supply: + 3.3V	

Note:

1. Pin1 is reversed as BIST function for test, don't connect signal to this pin, keep floating.
2. SEL6/8 is used for selecting 6bit/8bit LVDS data input, L or NC: 8bit; High:6bit.
3. Pin21,22,23 are used as SPI interface for OTP function, don't connect any signal to these pin, and don't short them, keep floating.
4. Reverse pin is used for selecting scanning direction.

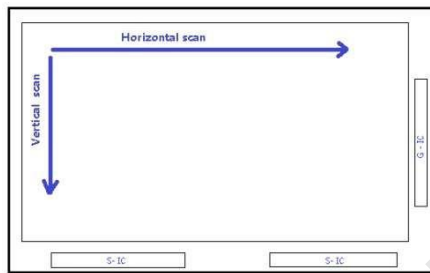

Fig. 1 Normal scan (Pin24, Reverse = Low or NC)



Fig. 2 Reverse scan (Pin24, Reverse = High)

## 5.2 BACKLIGHT UNIT (Converter connector pin)

### Connector 2: Cillux, CI4205M2HRD-NH

5-pin connector is used for input power & control signals for BL converter power IC

No	Symbol	I/O	Function	Remark
1	LED_VCCS	P	12V input	
2	LED_VCCS	P	12V input	
3	GND	P	Ground	
4	LED_PWM	I	PWM	
5	LED_EN	I	Converter power IC Enable (Active High)	

## 5.3 COLOR DATA INPUT ASSIGNMENT

The brightness of each primary color (red, green and blue) is based on the 8-bit gray scale data input for the color. The higher the binary input, the brighter the color. The table below provides the assignment of color versus data input.

Color		Data Signal																							
		Red								Green								Blue							
		R7	R6	R5	R4	R3	R2	R1	R0	G7	G6	G5	G4	G3	G2	G1	G0	B7	B6	B5	B4	B3	B2	B1	B0
Basic Colors	Black	0	0	0	0	0	0	0	0	0	0	0	0	0	0	0	0	0	0	0	0	0	0	0	
	Red	1	1	1	1	1	1	1	1	0	0	0	0	0	0	0	0	0	0	0	0	0	0	0	
	Green	0	0	0	0	0	0	0	0	1	1	1	1	1	1	1	1	0	0	0	0	0	0	0	
	Blue	0	0	0	0	0	0	0	0	0	0	0	0	0	0	0	0	1	1	1	1	1	1	1	
	Cyan	0	0	0	0	0	0	0	0	1	1	1	1	1	1	1	1	1	1	1	1	1	1	1	
	Magenta	1	1	1	1	1	1	1	1	0	0	0	0	0	0	0	0	1	1	1	1	1	1	1	
	Yellow	1	1	1	1	1	1	1	1	1	1	1	1	1	1	1	1	0	0	0	0	0	0	0	
	White	1	1	1	1	1	1	1	1	1	1	1	1	1	1	1	1	1	1	1	1	1	1	1	
Gray Scale Of Red	Red(0) / Dark	0	0	0	0	0	0	0	0	0	0	0	0	0	0	0	0	0	0	0	0	0	0		
	Red(1)	0	0	0	0	0	0	0	1	0	0	0	0	0	0	0	0	0	0	0	0	0	0		
	Red(2)	0	0	0	0	0	0	1	0	0	0	0	0	0	0	0	0	0	0	0	0	0	0		
	⋮	⋮	⋮	⋮	⋮	⋮	⋮	⋮	⋮	⋮	⋮	⋮	⋮	⋮	⋮	⋮	⋮	⋮	⋮	⋮	⋮	⋮			
	⋮	⋮	⋮	⋮	⋮	⋮	⋮	⋮	⋮	⋮	⋮	⋮	⋮	⋮	⋮	⋮	⋮	⋮	⋮	⋮	⋮	⋮			
	Red(253)	1	1	1	1	1	1	0	1	0	0	0	0	0	0	0	0	0	0	0	0	0	0		
	Red(254)	1	1	1	1	1	1	1	0	0	0	0	0	0	0	0	0	0	0	0	0	0	0		
	Red(255)	1	1	1	1	1	1	1	1	0	0	0	0	0	0	0	0	0	0	0	0	0	0		
Gray Scale Of Green	Green(0) / Dark	0	0	0	0	0	0	0	0	0	0	0	0	0	0	0	0	0	0	0	0	0	0		
	Green(1)	0	0	0	0	0	0	0	0	0	0	0	0	0	0	1	0	0	0	0	0	0	0		
	Green(2)	0	0	0	0	0	0	0	0	0	0	0	0	0	1	0	0	0	0	0	0	0	0		
	⋮	⋮	⋮	⋮	⋮	⋮	⋮	⋮	⋮	⋮	⋮	⋮	⋮	⋮	⋮	⋮	⋮	⋮	⋮	⋮	⋮	⋮			
	⋮	⋮	⋮	⋮	⋮	⋮	⋮	⋮	⋮	⋮	⋮	⋮	⋮	⋮	⋮	⋮	⋮	⋮	⋮	⋮	⋮	⋮			
	Green(253)	0	0	0	0	0	0	0	0	1	1	1	1	1	1	0	1	0	0	0	0	0	0		
	Green(254)	0	0	0	0	0	0	0	0	1	1	1	1	1	1	1	0	0	0	0	0	0	0		
	Green(255)	0	0	0	0	0	0	0	0	1	1	1	1	1	1	1	1	0	0	0	0	0	0		
Gray Scale Of Blue	Blue(0) / Dark	0	0	0	0	0	0	0	0	0	0	0	0	0	0	0	0	0	0	0	0	0	0		
	Blue(1)	0	0	0	0	0	0	0	0	0	0	0	0	0	0	0	0	0	0	0	0	0	1		
	Blue(2)	0	0	0	0	0	0	0	0	0	0	0	0	0	0	0	0	0	0	0	0	0	1		
	⋮	⋮	⋮	⋮	⋮	⋮	⋮	⋮	⋮	⋮	⋮	⋮	⋮	⋮	⋮	⋮	⋮	⋮	⋮	⋮	⋮	⋮			
	⋮	⋮	⋮	⋮	⋮	⋮	⋮	⋮	⋮	⋮	⋮	⋮	⋮	⋮	⋮	⋮	⋮	⋮	⋮	⋮	⋮	⋮			
	Blue(253)	0	0	0	0	0	0	0	0	0	0	0	0	0	0	0	1	1	1	1	1	1	0		
	Blue(254)	0	0	0	0	0	0	0	0	0	0	0	0	0	0	0	1	1	1	1	1	1	1		
	Blue(255)	0	0	0	0	0	0	0	0	0	0	0	0	0	0	0	1	1	1	1	1	1	1		

Note (1) 0: Low Level Voltage, 1: High Level Voltage

**6. INTERFACE TIMING**

**6.1 INPUT SIGNAL TIMING SPECIFICATIONS**

The input signal timing specifications are shown as the following table and timing diagram.

Signal	Item	Symbol	Min.	Typ.	Max.	Unit	Note
DCLK	Frequency	Fc	55	65	75	MHZ	
Vertical Active Display Term	Total	Tv	770	806	950	Th	Tv=Tvd+Tvb
	Display	Tvd	768	768	768	Th	-
	Blank	Tvb	2	38	182	Th	-
Horizontal Active Display Term	Total	Th	1104	1344	1800	Tc	Th=Thd+Thb
	Display	Thd	1024	1024	1024	Tc	-
	Blank	Thb	76	320	776	Tc	-

Note (1) Since this assembly is operated in DE only mode, Hsync and Vsync input signals should be set to low logic level. Otherwise, this assembly would operate abnormally.

(2) Frame rate is 60Hz

(3) The Tv(Tvd+Tvb) must be integer, otherwise, this module would operate abnormally.

**INPUT SIGNAL TIMING DIAGRAM**

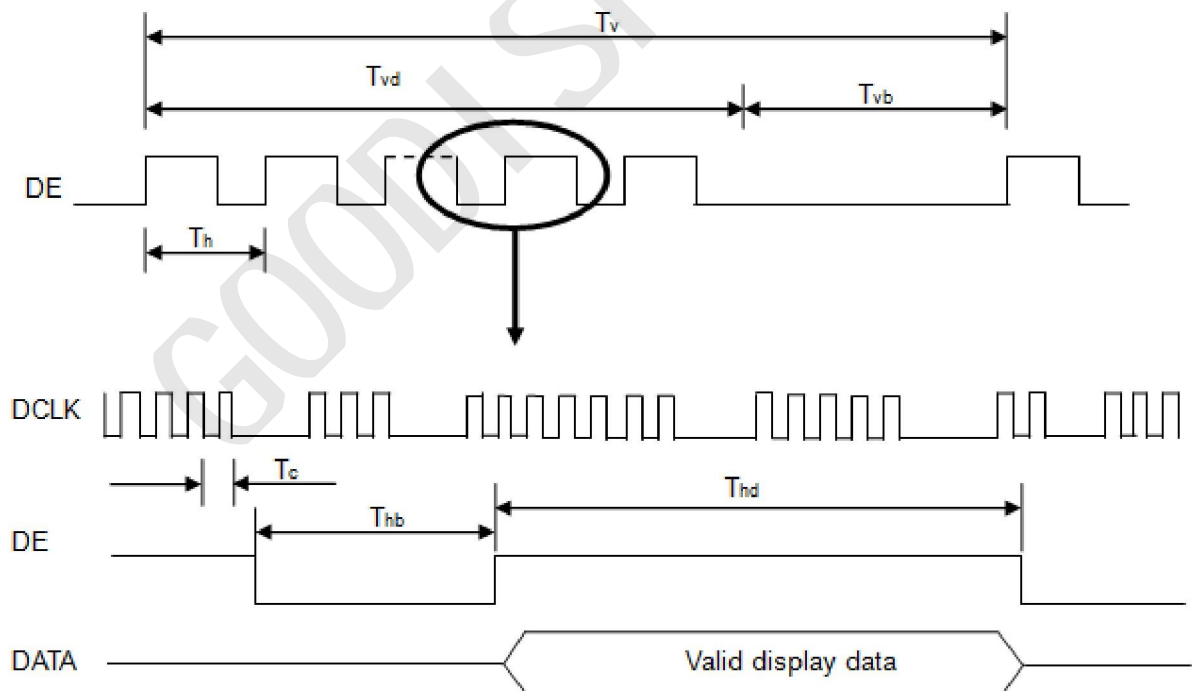

## 6.2 POWER ON/OFF SEQUENCE

To prevent a latch-up or DC operation of LCD assembly, the power on/off sequence should be as the diagram below.

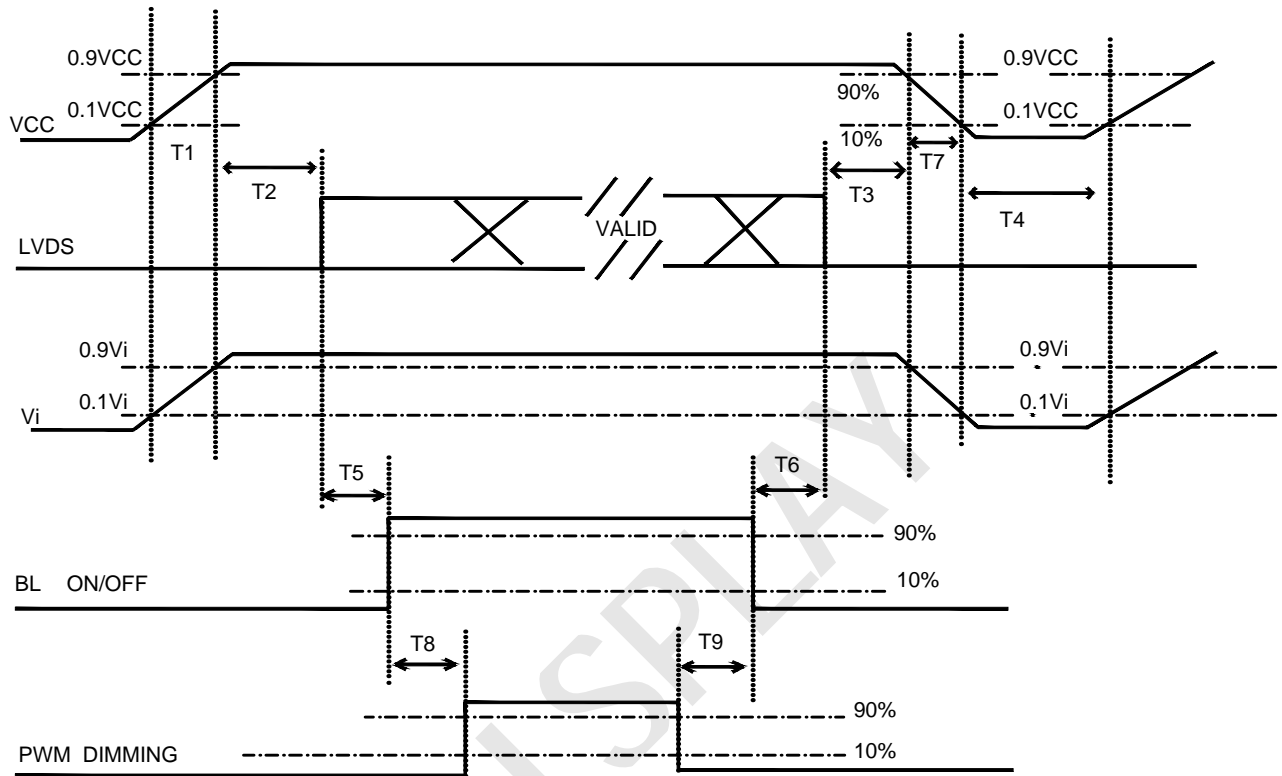

**Power ON/OFF sequence**

Note (1) Please avoid floating state of interface signal at invalid period.

Note (2) When the interface signal is invalid, be sure to pull down the power supply of LCD VCC to 0 V.

Note (3) The Backlight converter power must be turned on after the power supply for the logic and the interface signal is valid. The Backlight converter power must be turned off before the power supply for the logic and the interface signal is invalid.

Parameter	Value			Units
	Min	Typ	Max	
T1	0.5	-	10	ms
T2	0	-	50	ms
T3	0	-	50	ms
T4	500	-	-	ms
T5	200	-	-	ms
T6	20	-	-	ms
T7	5	-	300	ms
T8	10	-	-	ms
T9	10	-	-	ms



6.3 THE INPUT DATA FORMAT

**SEL 6/8 = “High” for 6 bits LVDS Input**

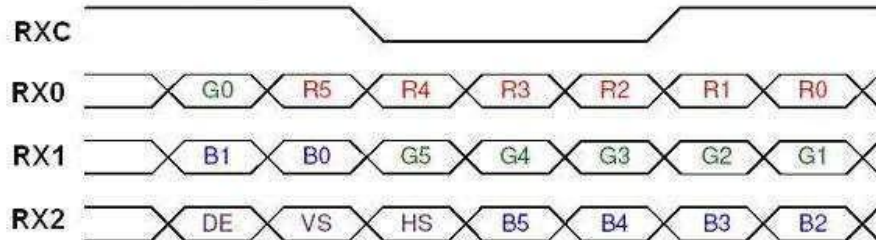

**SEL 6/8 = “Low” or “NC” for 8 bits LVDS Input**



Note (1) R/G/B data 7: MSB, R/G/B data 0: LSB

Note (2) Please follow PSWG

Signal Name	Description	Remark
R7	Red Data 7 (MSB)	Red-pixel Data Each red pixel's brightness data consists of these 8 bits pixel data.
R6	Red Data 6	
R5	Red Data 5	
R4	Red Data 4	
R3	Red Data 3	
R2	Red Data 2	
R1	Red Data 1	
R0	Red Data 0 (LSB)	
G7	Green Data 7 (MSB)	Green-pixel Data Each green pixel's brightness data consists of these 8 bits pixel data.
G6	GreenData 6	
G5	GreenData 5	
G4	GreenData 4	
G3	GreenData 3	
G2	GreenData 2	
G1	GreenData 1	
G0	GreenData 0 (LSB)	
B7	Blue Data 7 (MSB)	Blue-pixel Data Each blue pixel's brightness data consists of these 8 bits pixel data.
B6	Blue Data 6	
B5	Blue Data 5	
B4	Blue Data 4	
B3	Blue Data 3	
B2	Blue Data 2	
B1	Blue Data 1	
B0	Blue Data 0 (LSB)	
RXCLKIN+ RXCLKIN-	LVDS Clock Input	
DE	Display Enable	
VS	Vertical Sync	
HS	Horizontal Sync	

Note (3) Output signals from any system shall be low or Hi-Z state when VCC is off

### 6.4 SCANNING DIRECTION

The following figures show the image see from the front view. The arrow indicates the direction of scan.

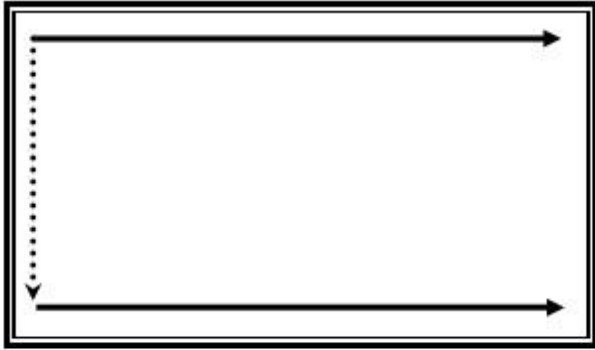

RPFI = Low/floating; normal display (default)

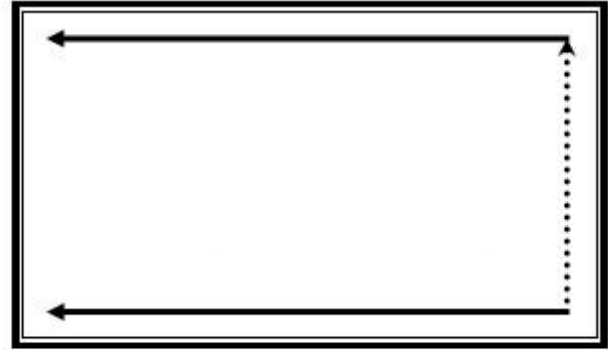

RPFI = high: display with 180degree rotation

GOODDISPLAY

## 7. OPTICAL CHARACTERISTICS

### 7.1 TEST CONDITIONS

Item	Value	Unit
Ambient Temperature (Ta)	25±2	°C
Ambient Humidity (Ha)	50±10	%RH
Supply Voltage	According to typical value in "ELECTRICAL CHARACTERISTICS"	
Input Signal		
LED Light Bar Input Current Per Input Pin		

### 7.2 OPTICAL SPECIFICATIONS

The relative measurement methods of optical characteristics are shown in 7.2 and all items are measured at the center point of screen except white variation. The following items should be measured under the test conditions described in 7.1 and stable environment shown in Note (6).

Item	Symbol	Condition	Min.	Typ.	Max.	Unit	Note	
Contrast Ratio	CR	$\theta_x=0^\circ, \theta_y=0^\circ$ Viewing angle at normal direction	700	1000	-	-	(2)	
Response Time	T <sub>R</sub>		-	14	19	ms	(3)	
	T <sub>F</sub>		-	11	16	ms		
Center Luminance of White	L <sub>C</sub>		480	600	-	cd/m <sup>2</sup>	(4)	
White Variation	$\delta W$		-	-	1.4	-	(7)	
Cross Talk	CT		-	-	4	%	(5)	
Chromaticity	Red		R <sub>x</sub>	Typ. -0.05	0.610	Typ. +0.05	-	(6)
			R <sub>y</sub>		0.365		-	
	Green		G <sub>x</sub>		0.341		-	
			G <sub>y</sub>		0.564		-	
	Blue	B <sub>x</sub>	0.147		-			
		B <sub>y</sub>	0.087		-			
	White	W <sub>x</sub>	0.313		-			
		W <sub>y</sub>	0.329		-			
Viewing Angle	Horizontal	$\theta_{x+}$	80	88	-	Deg.	(1)	
		$\theta_{x-}$	80	88	-			
	Vertical	$\theta_{y+}$	80	88	-			
		$\theta_{y-}$	80	88	-			

Note (1) Definition of Viewing Angle ( $\theta_x, \theta_y$ ):

Viewing angles are measured by BM5A

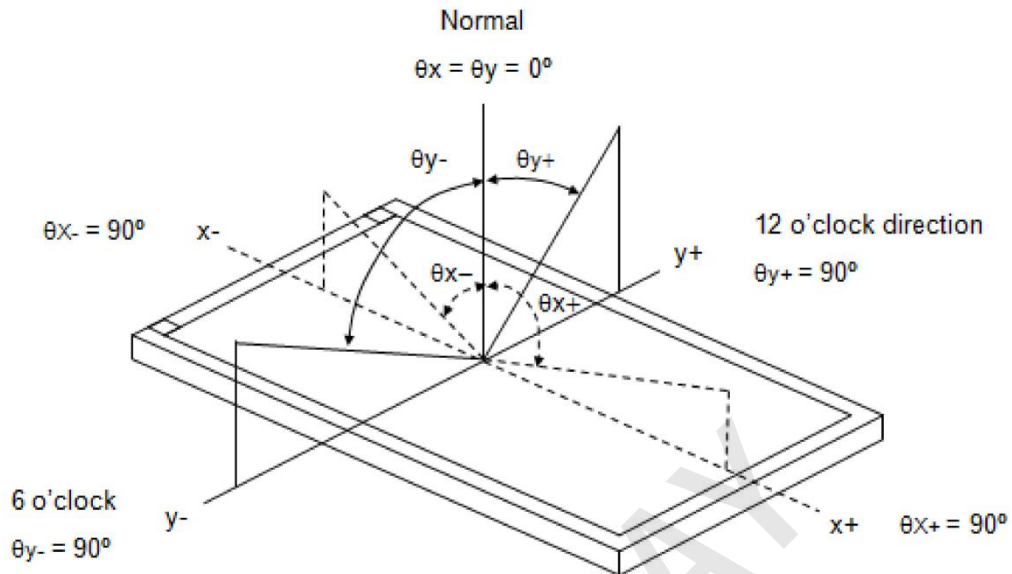

Note (2) Definition of Contrast Ratio (CR):

The contrast ratio can be calculated by the following expression.

$$\text{Contrast Ratio (CR)} = L_{255} / L_0$$

L<sub>255</sub>: Luminance of gray level 255

L<sub>0</sub>: Luminance of gray level 0

CR = CR (5), where CR (X) is corresponding to the Contrast Ratio of the point X at the figure in Note (7).

Note (3) Definition of Response Time (TR, TF):

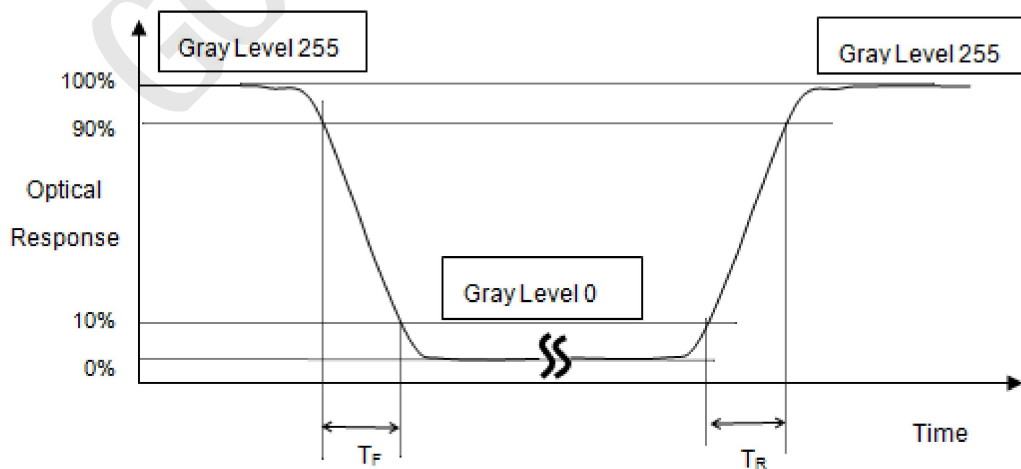

Note (4) Definition of Luminance of White (LC):

Measure the luminance of gray level 255 at center point and 5 points

L<sub>c</sub> = L (5), where L (X) is corresponding to the luminance of the point X at the figure in Note (7).

Note (5) Definition of Cross Talk (CT):

$$CT = | Y_B - Y_A | / Y_A \times 100 (\%)$$

Where:

$Y_A$  = Luminance of measured location without gray level 0 pattern ( $cd/m^2$ )

$Y_B$  = Luminance of measured location with gray level 0 pattern ( $cd/m^2$ )

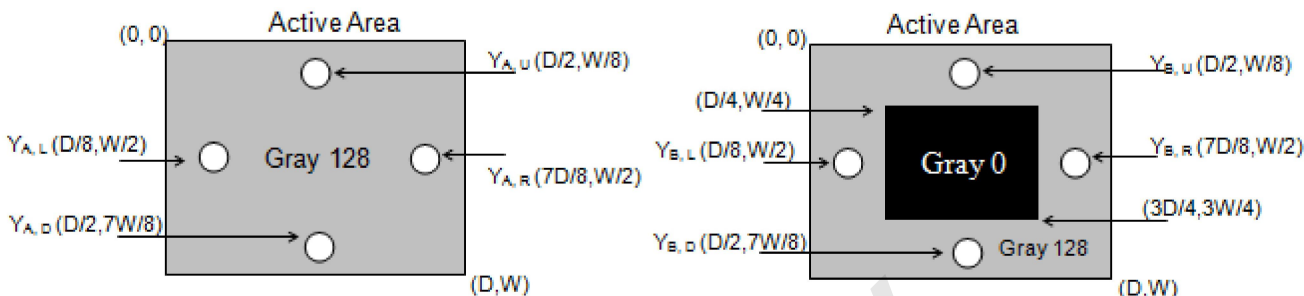

Note (6) Measurement Setup:

The LCD assembly should be stabilized at given temperature for 30 minutes to avoid abrupt temperature change during measuring. In order to stabilize the luminance, the measurement should be executed after lighting Backlight for 30 minutes in a windless room.

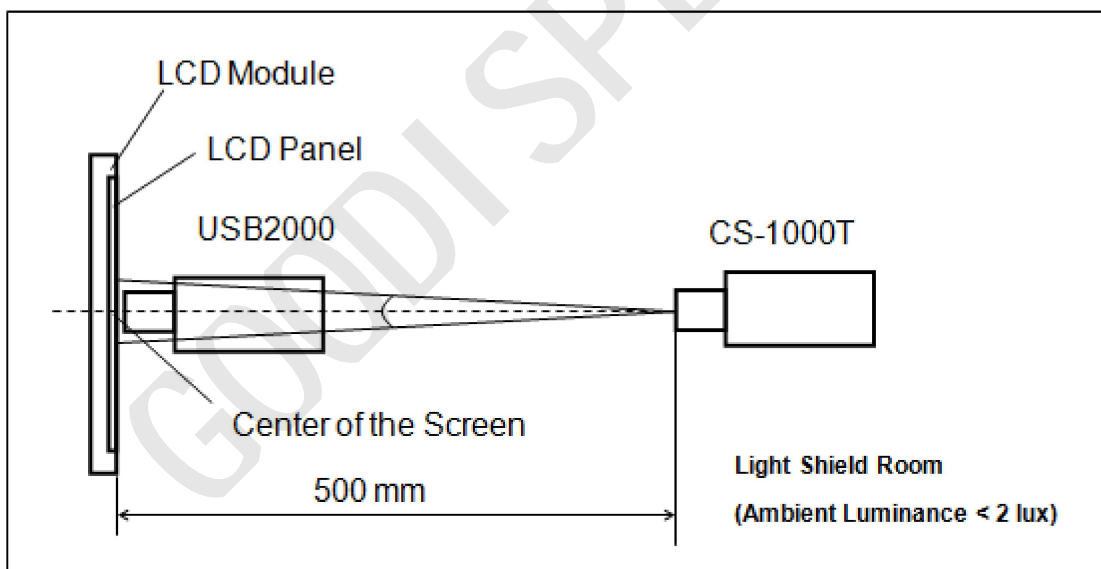

Note (7) Definition of White Variation ( $\delta W$ ):

Measure the luminance of gray level 255 at 5 points

$$\delta W = \text{Maximum [L (1), L (2), L (3), L (4), L (5)]} / \text{Minimum [L (1), L (2), L (3), L (4), L (5)]}$$

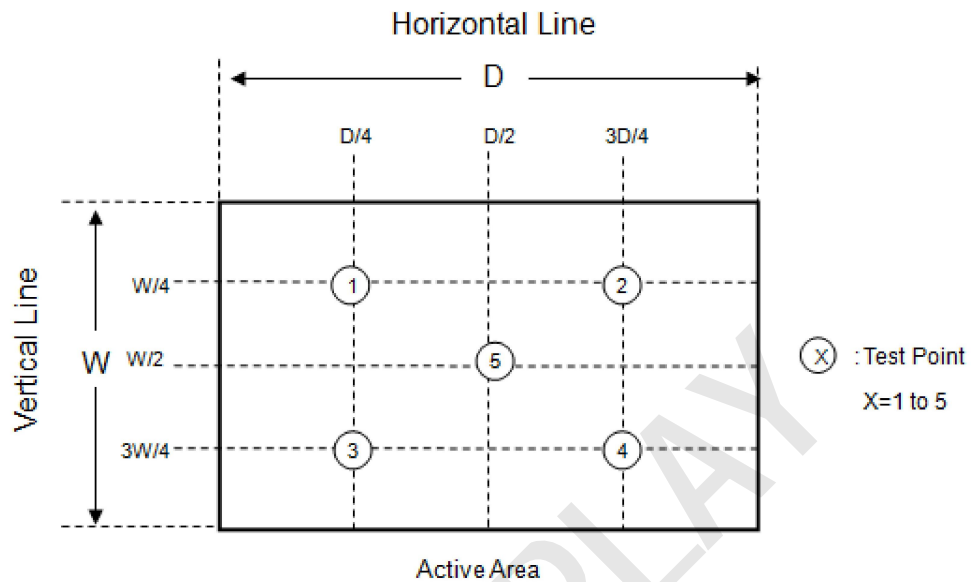

## 8. RELIABILITY TEST CRITERIA

Test Item	Test Condition	Note
High Temperature Storage Test	80°C, 240 hours	(1)
Low Temperature Storage Test	-30°C, 240 hours	(2)
Thermal Shock Storage Test	-30°C, 0.5hour↔80°C, 0.5hour; 100cycles, 1hour/cycle	(4)
High Temperature Operation Test	80°C, 240 hours	(5)
Low Temperature Operation Test	-30°C, 240 hours	(5)
High Temperature & High Humidity Operation Test	60°C, 90%RH, 240hours	(1) (2) (4) (6)
Electro Static Discharge	Air discharge: +/-8KV, Contact discharge:4KV	

Note (1) There should be no condensation on the surface of panel during test.

Note (2) Temperature of panel display surface area should be 87 °C Max.

Note (3) At testing Vibration and Shock, the fixture in holding the module has to be hard and rigid enough so that the module would not be twisted or bent by the fixture.

Note (4) In the standard conditions, there is no function failure issue occurred. All the cosmetic specification is judged before the reliability test.

Note (5) Before cosmetic and function test, the product must have enough recovery time, at least 2 hours at room temperature.

Note (6) Before cosmetic and function test, the product must have enough recovery time, at least 24 hours at room temperature.

**9.DEFINITION OF LABELS**

The barcode nameplate is pasted on each module as illustration, and its definitions are as following explanation.



- (a)Model Name: **GDTL104XL-S03**
- (b)Serial ID: XXXXXXXX YWXXXXXXXXXX

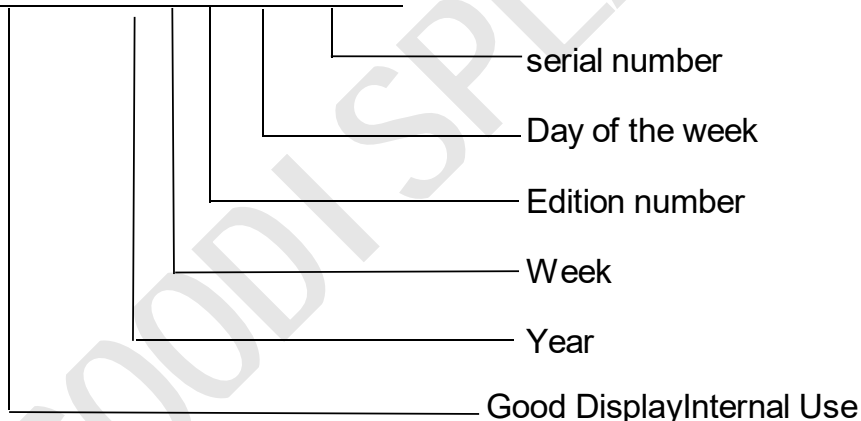

Serial ID includes the information as below:

- (a)Manufactured Date:  
 Year:00~99,...2019=19, 2020=20, 2021=21...,2028=28.  
 Week:01~56,first week of the year=01;second week of the year=02;...  
 Day of the week:A~G=Monday~Sunday
- (b) Edition number: cover all the change; A1,A2...Sample order;  
 C for mass production, C1, C2... change of order
- (c) Serial No.: Manufacturing sequence of product



客户承认

零件的平面翘曲度公差	
边长度L	对应公差范围
$L \leq 35$	$\leq 0.1\text{mm}$
$35 < L \leq 100$	$\leq L * 0.5\%$
$L > 100$	$\leq 0.5\text{mm}$

### 正视图

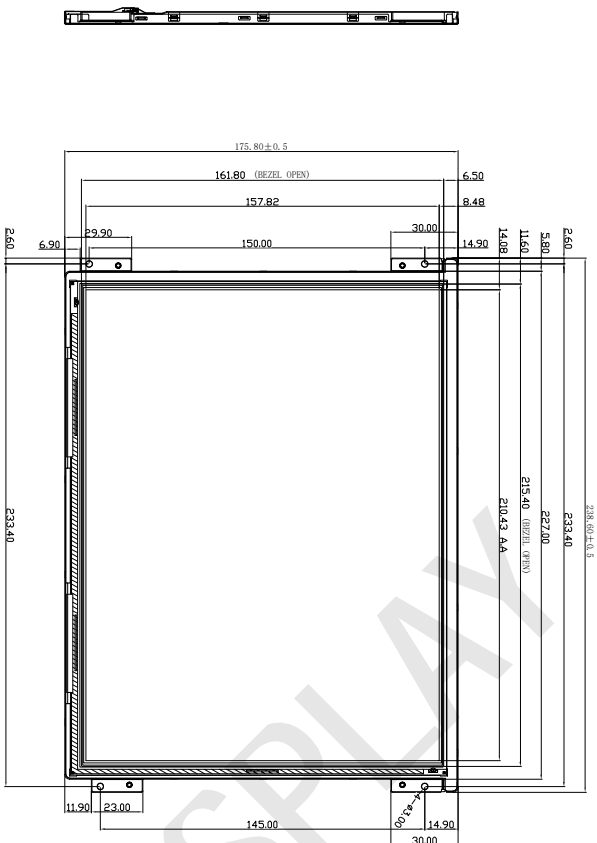

### 侧视图



### 背视图

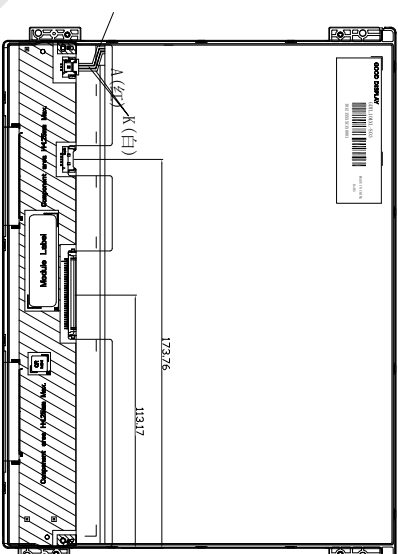

CN1 PIN Assignment

PIN#	Assignment
1	NC
2	GND
3	R1N3+
4	R1N3-
5	GND
6	CLK+
7	CLK-
8	GND
9	R1N2+
10	R1N2-
11	GND
12	R1N1+
13	R1N1-
14	GND
15	R1N0+
16	R1N0-
17	GND
18	NC
19	GND
20	SEL6/8
21	NC
22	NC
23	NC
24	Revers
25	GND
26	GND
27	GND
28	VDD
29	VDD
30	VDD

CN2 PIN Assignment

PIN#	Assignment
1	LED VCCS
2	LED VCCS
3	GND
4	LED PWM
5	LED EN

1. 显示模式: 10.4" Color TFT, Normally Black

2. 驱动 IC:

3. 工作温度: -30°C~80°C

4. 存储温度: -30°C~80°C

5. 未注尺寸公差按: ±0.5

6. 模组亮度 1000 cd/m2

7. 环保符合RoHS和REACH要求

8. 产品用途: 车载/工业

LED电路图

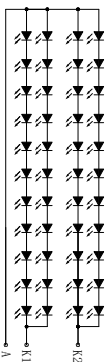

测试点分布

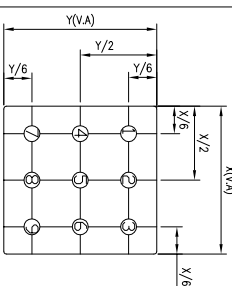

# DALIAN GOOD DISPLAY CO., LTD.

UNIT	mm	TITLE	模组工程图	NAME	DATE
RATIO:	1 : 1	PRODUCT NO	GDTL104XL-S03	DRAWN BY	GY_PAN 20.12.12
VIEW:		CUSTOMER NO		CHECKED BY	B_Luo 20.12.12
		REV		APPROVED BY	YB_Liu 20.12.12

V0

K

初版图纸

N

M

20.12.12

**11. PACKAGING**

1. packing bag

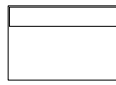

2. LCM

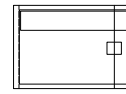
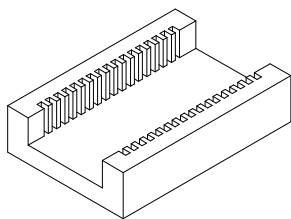
3. LCM into the packaging bag ,  
Seal the opening of the packing  
bag with sticky tape

4. Bottom pearl wool

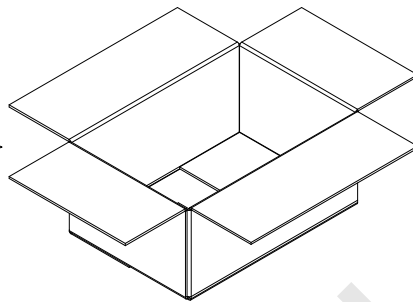

5. BOX

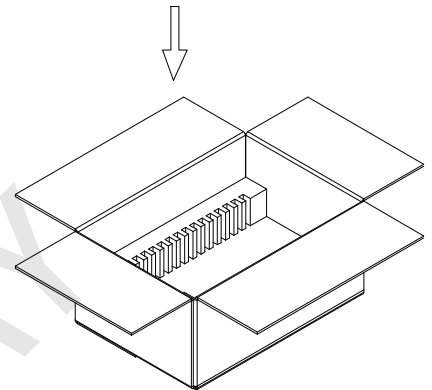
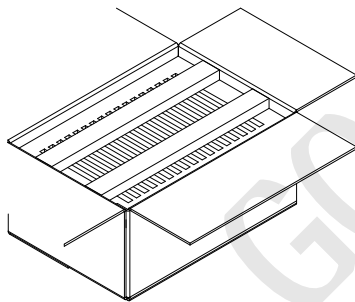
6. Put the bottom pearl  
wool into the box

9. Cover with Top pearl wool

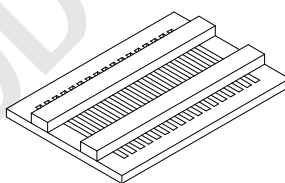

8. Top pearl wool

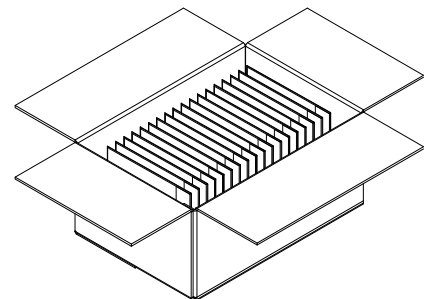
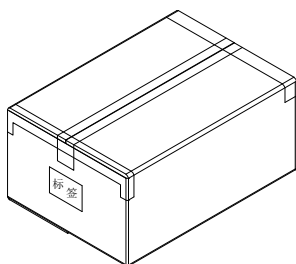
7. Put the products in the  
packaging bag, 1PCS  
for each card slot, with the  
TCON facing up10. Seal the case with transparent  
adhesive into "work" type seal,  
affixed to the outer label

## 12. PRECAUTIONS

### 12.1 ASSEMBLY AND HANDLING PRECAUTIONS

- (1) Do not apply rough force such as bending or twisting to the module during assembly.
- (2) It is recommended to assemble or to install a module into the user's system in clean working areas. The dust and oil may cause electrical short or worsen the polarizer.
- (3) Do not apply pressure or impulse to the module to prevent the damage of LCD panel and Backlight.
- (4) Always follow the correct power-on sequence when the LCD module is turned on. This can prevent the damage and latch-up of the CMOS LSI chips.
- (5) Do not plug in or pull out the I/F connector while the module is in operation.
- (6) Do not disassemble the module.
- (7) Use a soft dry cloth without chemicals for cleaning, because the surface of polarizer is very soft and easily scratched.
- (8) Moisture can easily penetrate into LCD module and may cause the damage during operation.
- (9) High temperature or humidity may deteriorate the performance of LCD module. Please store LCD modules in the specified storage conditions.
- (10) When ambient temperature is lower than 10°C, the display quality might be reduced. For example, the response time will become slow, and the starting voltage of backlight will be higher than that of room temperature.
- (11) Do not keep same pattern in a long period of time. It may cause image sticking on LCD.

### 12.2 SAFETY PRECAUTIONS

- (1) The startup voltage of a Backlight is approximately 1000 Volts. It may cause an electrical shock while assembling with the inverter. Do not disassemble the module or insert anything into the Backlight unit.
- (2) If the liquid crystal material leaks from the panel, it should be kept away from the eyes or mouth. In case of contact with hands, skin or clothes, it has to be washed away thoroughly with soap.
- (3) After the module's end of life, it is not harmful in case of normal operation and storage.