

ELECTRONIC BALANCE
(JA-P)

JA series precision electronic balance is a kind of intellectual measuring instrument with weighing, counting and other many functions. The product introduces imported integrated circuit and enjoys stable and reliable performance, easy operation and accurate weighing and counting, as a kind of measuring instrument.

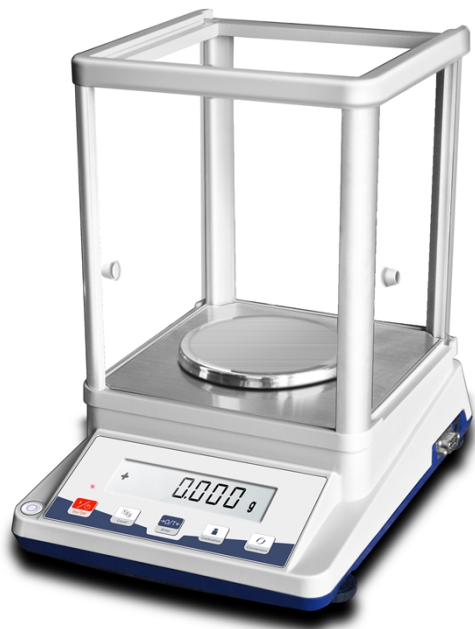

100g, the accurate will be change to “0.00”automatic.

Note: In order to protect the sensor and the procedure, if you need 0.01g precision, please replace the 0.01g readability

2. When the display show “0.00”, the max weight is 600g, and the total capacity is “0.00” accurate.

XIV Minimum weight setting

Under the weighing range you need, you can choose the minimum weight as your requirement, for example, we choose the “0.00” accurate, so we can set the minimum as following:

1. Turn on the balance when it display “0.00”
2. Press “→O/T←”+“COU”, when it will display “1d” (there are 1d to 5d five digits can choose)
3. Press “COU” or “CAL” to choose the minimum weighing you required.
then press “→O/T←” to confirm your choice.
4. If you need choose “0.000” minimum weighing, please choose the “0.000” accurate first.

XV Package list

Electronic Balance	1	Instruction Book	1
Weighing Tray	1	Power Adapter	1
Standard Mass	1		

I Model specification and index

Model	Capacity	Readability	Size Of Weighing Pan
JA103P	110g/1mg	1mg	Φ90mm
JA203P	210g/1mg		
JA303P	310g/1mg		
JA103PL	100g/1mg-600g/10mg	1mg/10mg	Φ110mm

- (1) Counting operation requires the weight of weighed thing must heavier than the four times of minimum reading value, or the difference of counting could be great if not counting can't be done.
- (2) Quit the counting operation:
Press the "COU" button and then "=====" will be displayed. The balance may quit counting operation state immediately and return the weighing state.
- (3) Overload warning
When weighing thing is over the maximum weighing value of the balance, the display will show "-----" and indicate the thing is overloaded. The weighing thing shall be removed to avoid damaging the balance.

XI Cautions

- (1) Please turn on and warm up the balance according the requirements before you weighing the things.
- (2) Working environment and conditions shall conform to the environment requirements.
- (3) The weight of all weighing things on the weighing tray can't exceed the required weighing range.
- (4) When weighing is not accurate, calibration shall be undertaken by use of standard weight according to concerning requirements.
- (5) If user found any defection in the balance, don't try to disassemble the machine shell and repair it to avoid damaging the precision parts in the machine. Please take it to the distributor or send it to the manufacturer and let them repair.

XII Unit Change

There are six units can be choose, press "UNIT" and choose the unit you need : gram , ct , oz.

XIII Weighing Range Setting

There are two weighing range can be choose (Just for JA103PL mode),

Press "→O/T←" + "UNIT" to change the "0.00" and "0.000".

1. When the display show "0.000" the max weight is 100g, if the weight more than

II Structure Diagram

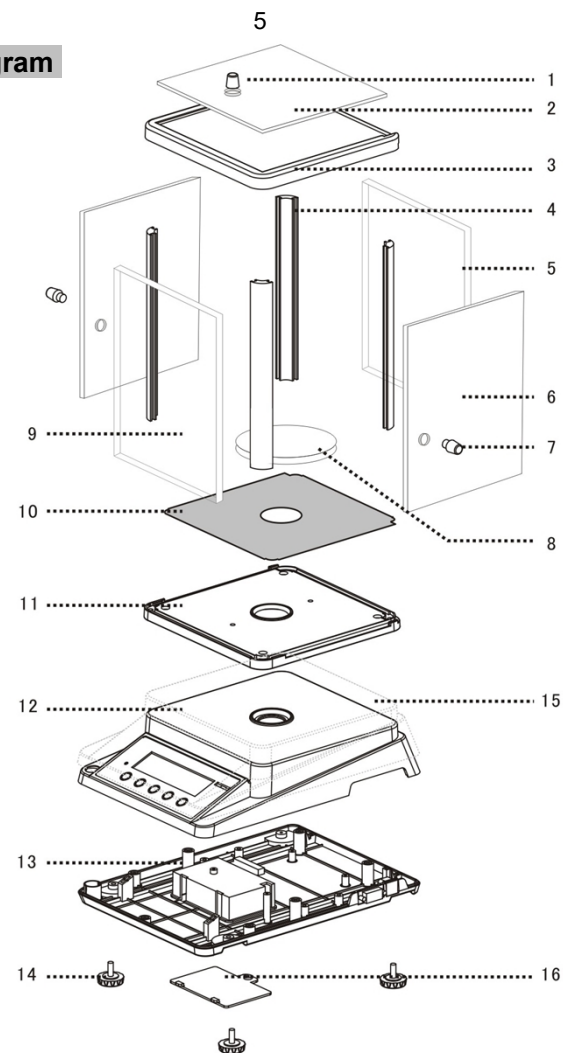

- | | |
|----------------|------------------|
| 1 Top Handle | 9 Front Glass |
| 2 Top Glass | 10 Under Tray |
| 3 Shell 01 | 11 Shell 02 |
| 4 Vertical Rod | 12 Shell 03 |
| 5 Back Glass | 13 Shell 04 |
| 6 Right Glass | 14 Adjust Feet |
| 7 Right Handle | 15 Dust Cover |
| 8 Weighing Pan | 16 Battery Cover |

III Display Icon

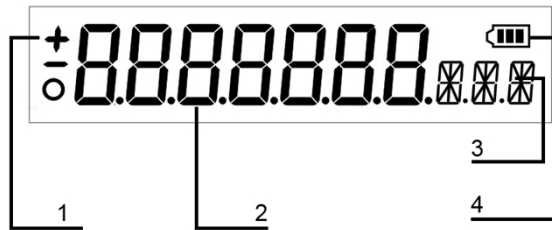

1. Status icon: "+" and "-" is the reading state, the "O" means the weighing process, when it disappears, the weighing is stable.
2. The digits: the digits mean the object weight
3. The unit icon
4. The residual capacity of the battery

IV Working Condition

Working Temperature: 0°~50°C, Maximum Consumed Power: 5W
 Temperature Fluctuation: 5°C/h, Power Supply: 100-240V, 50-60HZ
 Comparative Humidity: 50%~85%

V Operation Requirements

When it is operated, electronic balance shall be placed on stable working platform to avoid the influences from mechanical vibration, direct sunshine and air current etc.

VI Operation

Power-on: Press the "ON/OFF" key, and the display indicates in turn "8.8.8.8.8.8.", "-", "-", "-", "-", "-". At last it shall display the weighing "X.XXX". If any error founded in display, you may turn on and turn off the balance once more. Then it will be operated normally.

VII Calibration

(1) Calibration Requirements

When distinct errors appeared in the weighing of balance, the balance shall be recalibrated to make weighing accurate. The recalibrated balance shall be placed on the stable working platform without the influences from the vibration of air current and strong electromagnetic wave. The calibration results will be more accurate after turn on the scale and warm up for more than 20 minutes.

(2) Calibration Procedure

Turn on the balance it shall display the weighing mode as "0.000", then press the "CAL" button until shows "CAL", then release. Display blinkingly the standard weight value and then place same value standard weight; The "===== " will be displayed; then display stably weight value and remove weight. then "===== " will be displayed. the "0.000" will be displayed. The calibration is finished.

VIII Weighing

- (1) Turn on the balance to make it warm up stably and display "0.000".
- (2) Place a thing on the weighing tray and display the weight of the thing. It indicates the weight is already stable when the display value is not changed again.

IX Tare

- (1) If there is a container on the weighing tray, the balance displays the weight of container.
- (2) Press "→0/T←" and then "0.000" will be displayed. It indicates that the tare has been deducted.
- (3) Place the thing into container and the balance will display the weight of thing.

X The counting operation of balance

Press "COU" button and "COU" will be displayed. Then display blinkingly one of value of counting mode, "5,10,20, 40, 50, 100, 200, 300, 400, 500" Press "→0/T←" and choose one mode value. Place the things with same quantity with mode value on the weighing tray and then press "COU". Then "===== " will be displayed. Very soonly, it will display stable mode value and then the setting of counting operation is finished. After that, counting operation could be conducted. Place the things in the weighing tray

and display will show the quantity of thing.

4