



**NAK**<sup>TM</sup>

ISO-9001/14001  
ISO/TS-16949  
OHSAS-18001



# 液/氣壓密封件

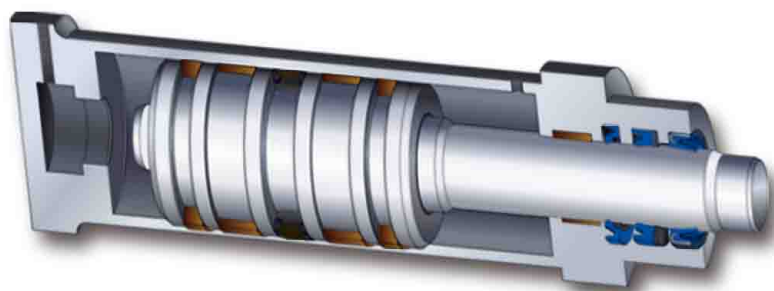

*Navigator of Sealing Technology*





# NAK Hydraulic & Pneumatic Seals



茂順創立於1976年，於2002年1月份以台灣第一家密封元件專業製造廠掛牌上市，高附加價值的產品及穩健經營的態勢已在國內外市場行銷多年，並以自創品牌「NAK」行銷全球五大洲。



茂順擁有強大研發團隊，除了自行設計開發及材質研究，更採取主動追蹤的經營態度，以顧客所需要的產品為開發對象，並與顧客相關單位人員聯繫、了解產品特性及品質機能，使產品開發的成功率大為提升，客戶滿意度亦相對提升。



研發導入FEA(電腦輔助分析)軟體，建立各種材質、壓力、溫昇、油膜理論分析；並自行開發SCAD軟體結合設計成品及模具，減少失敗並降低成本以達成最佳化的設計。



材研擁有設備齊全之材料配方研究實驗室，從配方研究開發、橡膠混煉、物性測試、膠料分析至品質檢驗一貫作業系統及技術。導入ASTM橡膠實驗方法，包含未硫化膠料加工特性量測、橡塑膠材質硬度量測、材料機械強度與接著強度量測、材料老化/耐油/耐低溫/壓縮變形回復性/彈性試驗、膠料混煉分散性觀測與FT-IR膠料分析等。

製模使用SMART CAM與CNC Machine Center連結，將模具生產精準化及有效率的串聯成模具生產網，使得產品品質更加有保障。

茂順朝向國際化經營之企業，以全球運籌管理模式運作，未來的發展方向，將會朝向產品差異化及全球化佈局。積極朝高科技與高附加價值之全系列密封元組件產品發展，擴大公司規模，提升技術層次，以強化技術服務團隊功能與能力，以因應市場變化，提升國際競爭優勢。藉由海外投資及策略聯盟建立全球行銷通路，產品多樣化，滿足客戶多元化的需求。





# 目錄

A. 液/氣壓密封系統說明與應用	5-6
B. 液/氣壓密封件的材料	7-8
C. 活塞桿油封與活塞油封的分類方法	9-11
D. 液/氣壓密封件的類型與特性	12-23
E. 液/氣壓密封件的尺寸表	24-181
E1. 活塞桿(Rod)密封件	
UIP	24-30
UIP2	31-41
UIP8	42
UNP2	43
CIP	44
UIB3	45
HRO	46
UIR	47
CIR	48
LIR	49
E2. 活塞(Piston)密封件	
UOP	50-54
COP	55
HOD	56
HPO	57
HPS	58
UOR	59
COR	60
PDV	61
PDC	62
PDH	63
PSC	64
PSV	65
PSV2	66

# 目錄

## E3. 活塞桿與活塞密封件 (For Rod & Piston)

UNP	67-79
UNP1	80-82
CNP	83
UNR	84-86
CNR	87
HB	88-94
HD	95-96
HS	97-99
HBX	100
HSX	101

## E4. 防塵(Wiper)密封件

WP1	102-104
WP2	105
WP3	106-110
WP4	111-112
WP5	113-115
WP6	116
WP7	117
WP8	118
WP10	119
WP11	120-121
WP16	122
WP21	123
WP22	124
WP32	125
WPB	126-127
WPC	128
WPK	129
WPM	130-133
WPR	134-135
WPV	136

WP12	137-138
WP13	139
WP14	140
WP15	141
WP17	142
WP19	143
WP24	144
WPK1	145
WPK3	146

## E5. 各種型環(Rings)

O-RING	147-171
X-RING	172-177
SQ-RING	178-180
D-RING	181

## F. 設計履歷 182-183





# 液/氣壓密封系統說明與應用

NAK液/氣壓密封件產品範圍包括活塞油封、活塞桿油封、防塵油封及耐磨環等。依據不同的液/氣壓運動情況，運用橡膠、聚氨酯、聚四氟乙烯、尼龍及其他材質，開發不同的油封產品。此類產品通常設計用於如氣壓缸及液壓缸的往復式作動產品。NAK提供的設計範圍廣泛，以符合液/氣壓工業設備嚴格的要求。

對於液氣壓設備而言，氣壓缸及液壓缸的設計越趨複雜與高科技。因此，對於氣壓缸及液壓缸產品應用，能提供較常使用壽命及可靠性的多樣化油封產品因應而生。對於液/氣壓之氣壓缸及液壓缸產品而言，密封元組件是不可或缺的產品。這些油封的主要功能是避免氣壓缸及液壓缸內流體或氣體洩漏以確保內部加壓與否狀態的正常功能。

## 液/氣壓缸密封件功能

防塵油封	避免外部汙染物進入系統內
活塞桿油封	裝置並固定於液/氣壓缸內徑以密封活塞桿
活塞油封	裝置並固定於活塞溝槽以密封液/氣壓缸
耐磨環	防止金屬與金屬碰觸

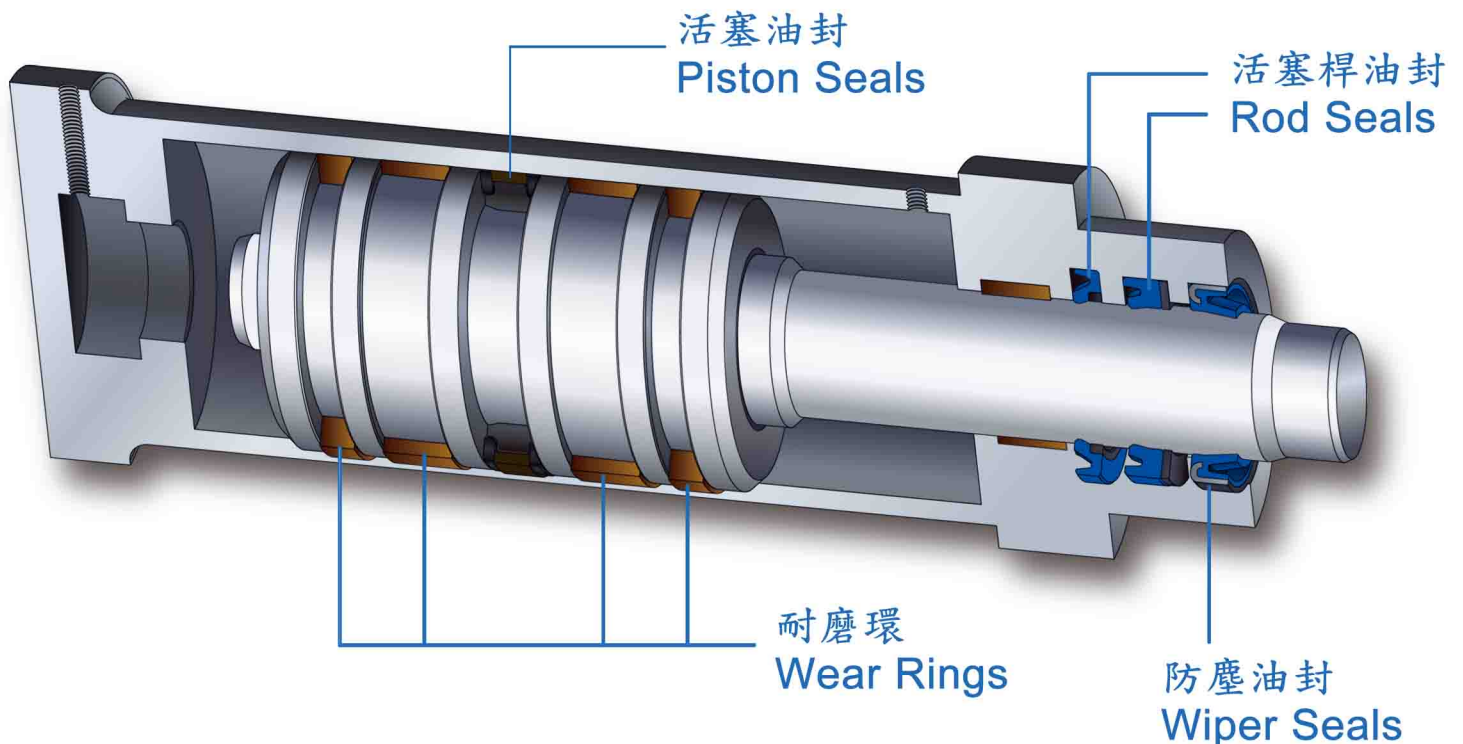





# 液/氣壓密封系統說明與應用

密封元組件是液/氣壓設備不可或缺的元素。這些油封的使用是非常關鍵的，它們使流體動力轉換成線性運動。然而，油封失效將對設備造成傷害。因此，裝置正確的油封產品是非常重要的。

選擇適當的液/氣壓密封產品主要依據以下因素：

- ☑ 應用環境：液壓或氣動；活塞或活塞桿；
- ☑ 尺寸：軸表面及外殼口徑狀況；使用於液體或氣體的情況下。
- ☑ 溫度：流體溫度及作業溫度。平均溫度與最高溫度都需要納入考量。
- ☑ 壓力：靜態與動態壓力均需注意。最大作業壓力也是重要參數之一。
- ☑ 線性速度：氣壓缸及液壓缸擊動次數，最大速度等等。
- ☑ 媒介/流體：媒介的形式及量等等。

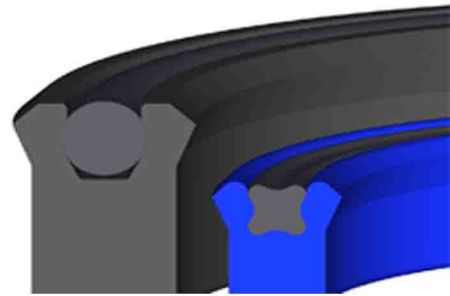
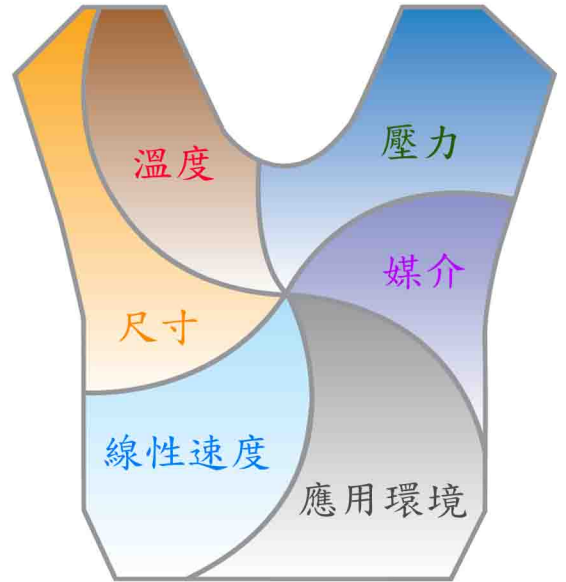



# 液/氣壓密封件的材料

種類 \ 項目	適用溫度範圍 (°C)		材料特性摘要
	低溫	高溫	
NBR 丁腈橡膠	-40	100	由於兼具耐油性及耐磨耗佳，因此為一使用於油封材料最多的耐油膠，特別是對礦物系的抵抗性最佳，不適用於酮類的極性溶劑中。
FKM 氟橡膠	-25	250	耐高溫及耐化學藥品特優是二大特質，除了酮類及酯類外，可耐大部份的油及溶劑。
PU 聚氨酯	-40	100	良好的抗張強度、耐磨性、撕裂強度和擠壓強度，但不抗極性溶劑、剎車油、酸、鹼。

## NBR 丁腈橡膠

丁腈橡膠(NBR)是由丙烯腈(Acrylonitrile)與丁二烯(Butadiene)藉由乳液聚合法製得，它有良好的物理性質及機械性質，因此普遍運用於密封材料上。丙烯腈含量多寡會影響 NBR 性質，如丙烯腈含量多時它的硬度、抗張強度、耐油及耐熱性等等都會提升；含量少時彈性及耐低溫性會增加。由於 NBR 的耐油性很好，再經過配方設計後能改善抗臭氧的侵蝕，所以常被使用於油壓和氣壓密封系統。

## FKM 氟橡膠

一般氟橡膠的氟含量大約在 66 到 70% 就有很好的特性，如耐候性、耐化學性、耐高溫性以及良好的抗張強度與低壓縮變型。此外，它還可以抵抗各種礦物油和合成機油，相反的它不耐極性溶劑。

## PU 聚氨酯

聚氨酯是一種熱可塑彈性體材料，由於具有良好的物理特性因此用於密封元件很多年。聚氨酯是一個有機高分子材料，經由聚亞氨基酯和多元醇在催化劑和其它助劑存在下加成聚合反應而生成。此外，它的特點是有良好的機械性質，例如：抗張强度高、耐磨性、撕裂強度和擠壓強度。但是，它不耐極性溶劑、剎車油、酸、鹼。



# 液/氣壓密封件的材料





材料	配方代號	硬度 (Shore A)	溫度範圍 (°C)	特性
NBR 丁腈橡膠	NK761	71	-40 ~ 100	良好的耐油及耐磨性
	NKC61	75	-40 ~ 100	良好的耐油及耐低溫性
	NK961	87	-35 ~ 100	良好的耐油及耐壓性
FKM 氟橡膠	VN761	71	-25 ~ 200	極佳的耐高溫與耐候性
	VNC06	75	-25 ~ 200	耐往復運動與耐高溫性
	VN901	88	-20 ~ 200	高硬度與耐高溫性
PU 聚氨酯	UB903	94	-40 ~ 100	良好的耐壓、耐磨性及低壓縮變形性
	UB904	94	-40 ~ 100	良好的耐壓及耐磨性
	UK908	95	-40 ~ 100	良好的耐壓及耐磨性

項目 種類	耐油性	耐鹼性	耐酸性	耐水性	耐候性	耐磨性
NBR 丁腈橡膠	◎	○	○	○	△	◎
FKM 氟橡膠	◎	△	○	○	◎	◎
PU 聚氨酯	◎	△	△	△	◎	◎



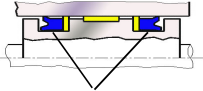
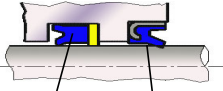
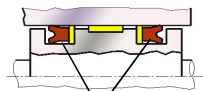

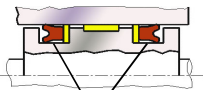
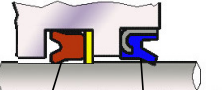

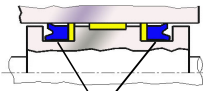
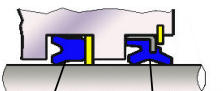
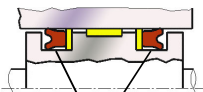
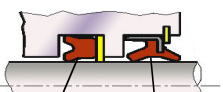
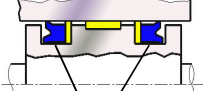
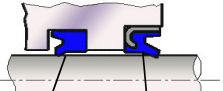

◎：優良      ○：除特定情況外，具有抗性      △：除特定情況外，不具抗性      ✕：不具抗性

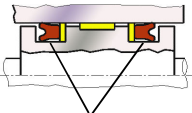
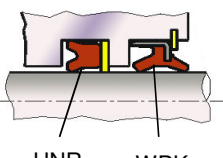

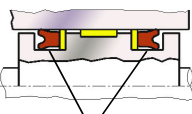
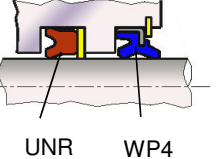

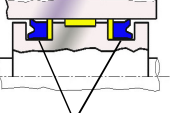
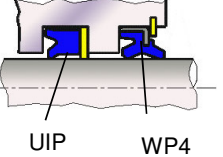

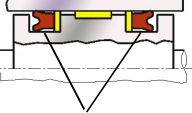
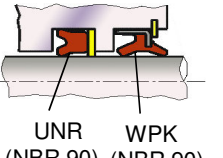
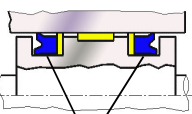
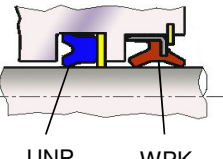

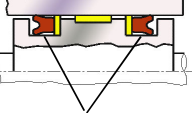
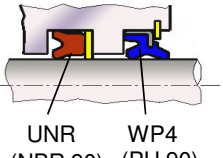

# 活塞桿(ROD)油封與活塞(PISTON)油封的分類方法

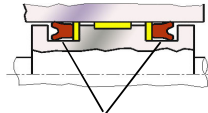
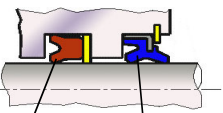
設備	應用環境	活塞油封系統	特點	活塞桿油封系統	特點
	0 ~ 20 Mpa -30 ~ 100°C	 UOP (PU 90)	UOP 具有極佳的耐磨及密封性能。	 UIP (PU 90)      WP3 (PU 90)	UIP 內外密封唇具有非對稱的設計。  WP3 可避免灰塵入侵至油壓缸內，以維持內部密封件的性能。
	Heat-resistant 0 ~ 14 Mpa -25 ~ 200°C	 UNR (FKM 90)	UNR 內外密封唇具有對稱的設計及相同的高度。	 UNR (FKM 90)      WP4 (PU 90)	UNR 內外密封唇具有對稱的設計及相同的高度。  WP4 可避免灰塵入侵至油壓缸內，以維持內部密封件的性能且其雙主唇設計可防止流體被帶出。
	0 ~ 14 Mpa -30 ~ 100°C	 UNR (NBR 90)	UNR 內外密封唇具有對稱的設計及相同的高度。	 UNR (NBR 90)      WP3 (PU 90)	UNR 內外密封唇具有對稱的設計，及相同的高度。  WP3 可避免灰塵入侵至油壓缸內，以維持內部密封件的性能。
	0 ~ 14 Mpa -30 ~ 100°C	 UOP (PU 90)	UOP 具有極佳的耐磨及密封性能。	 UNP (PU 90)      WP4 (PU 90)	UNP 內外密封唇具有對稱的設計及相同的高度。具有極佳的耐磨及密封性能。  WP4 可避免灰塵入侵至油壓缸內，以維持內部密封件的性能且其雙主唇設計可防止流體被帶出。
	0 ~ 14 Mpa -30 ~ 100°C	 UNR (NBR 90)	UNR 內外密封唇具有對稱的設計及相同的高度。	 UNR (NBR 90)      WPK (NBR 90)	UNR 內外密封唇具有對稱的設計及相同的高度。  WPK 可避免灰塵入侵至油壓缸內，以維持內部密封件的性能且其雙主唇設計可防止流體被帶出。
	0 ~ 20 Mpa -30 ~ 100°C	 UOP (PU 90)	UOP 具有極佳的耐磨及密封性能。	 UIP (PU 90)      WP3 (PU 90)	UIP 內外密封唇具有非對稱的設計。  WP3 可避免灰塵入侵至油壓缸內，以維持內部密封件的性能。

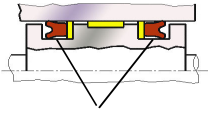
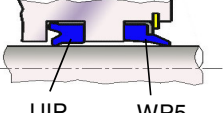
# 活塞桿(ROD)油封與活塞 (PISTON)油封的分類方法

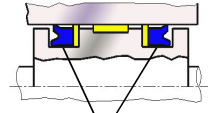
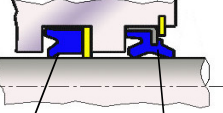
設備	應用環境	活塞油封系統	特點	活塞桿油封系統	特點
	0 ~ 14 Mpa -30 ~ 100°C	 UNR (NBR 90)	UNR 內外密封唇具有對稱的設計及相同的高度。	 UNR (NBR 90) WPK (NBR 90)	UNR 內外密封唇具有對稱的設計及相同的高度。 WPK 可避免灰塵入侵至油壓缸內，以維持內部密封件的性能且其雙主唇設計可防止流體被帶出。
	0 ~ 14 Mpa -30 ~ 100°C	 UNR (NBR 90)	UNR 內外密封唇具有對稱的設計及相同的高度。	 UNR (NBR 90) WP4 (PU 90)	UNR 內外密封唇具有對稱的設計及相同的高度。 WP4 可避免灰塵入侵至油壓缸內，以維持內部密封件的性能且其雙主唇設計可防止流體被帶出。
	0 ~ 20 Mpa -30 ~ 100°C	 UOP (PU 90)	UOP 具有極佳的耐磨及密封性能。	 UOP (PU 90) WP4 (PU 90)	UOP 內外密封唇具有非對稱的設計。 WP4 可避免灰塵入侵至油壓缸內，以維持內部密封件的性能且其雙主唇設計可防止流體被帶出。
	0 ~ 14 Mpa -30 ~ 100°C	 UNR (NBR 90)	UNR 內外密封唇具有對稱的設計及相同的高度。	 UNR (NBR 90) WPK (NBR 90)	UNR 內外密封唇具有對稱的設計及相同的高度。 WPK 可避免灰塵入侵至油壓缸內，以維持內部密封件的性能且其雙主唇設計可防止流體被帶出。
	0 ~ 20 Mpa -30 ~ 100°C	 UOP (PU 90)	UOP 具有極佳的耐磨及密封性能。	 UNP (PU 90) WPK (NBR 90)	UNP 內外密封唇具有對稱的設計及相同的高度。 WPK 可避免灰塵入侵至油壓缸內，以維持內部密封件的性能且其雙主唇設計可防止流體被帶出。
	0 ~ 14 Mpa -30 ~ 100°C	 UNR (NBR 90)	UNR 內外密封唇具有對稱的設計及相同的高度。	 UNR (NBR 90) WP4 (PU 90)	UNR 內外密封唇具有對稱的設計及相同的高度。 WP4 可避免灰塵入侵至油壓缸內，以維持內部密封件的性能且其雙主唇設計可防止流體被帶出。

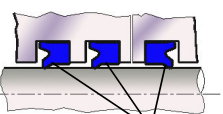

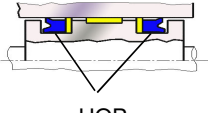



# 活塞桿(ROD)油封與活塞 (PISTON)油封的分類方法

設備	應用環境	活塞油封系統	特點	活塞桿油封系統	特點
	0 ~ 14 Mpa -30 ~ 100°C	 UNR (NBR 90)	UNR 內外密封唇具有對稱的設計及相同的高度。	 UNR (NBR 90)    WP4 (PU 90)	UNR 內外密封唇具有對稱的設計及相同的高度。  WP4 可避免灰塵入侵至油壓缸內，以維持內部密封件的性能且其雙主唇設計可防止流體被帶出。
	0 ~ 14 Mpa -30 ~ 100°C	 UNR (NBR 90)	UNR 內外密封唇具有對稱的設計及相同的高度。	 UIP (NBR 90)    WP5 (PU 90)	UIP 內外密封唇具有非對稱的設計。  WP5 具有高防塵性能，可避免灰塵入侵至油壓缸內，以維持內部密封件的性能。
	0 ~ 20 Mpa -30 ~ 100°C	 UOP (PU 90)	UOP 內外密封唇具有非對稱的設計。	 UIP (PU 90)    WP4 (PU 90)	UIP 內外密封唇具有非對稱的設計。  WP4 具有高防塵性能，可避免灰塵入侵至油壓缸內，以維持內部密封件的性能且其雙主唇設計可防止流體被帶出。
	0 ~ 16 Mpa -30 ~ 100°C	-	-	 UIP (PU 90)	UIP 內外密封唇具有非對稱的設計。
	0 ~ 16 Mpa -30 ~ 100°C	 UOP (PU 90)	UOP 內外密封唇具有非對稱的設計。	-	-



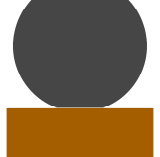

# 液/氣壓密封件的類型與特性

## 活塞桿(ROD)密封件

類型	剖面圖	使用條件				特性	應用環境	頁次
		材質	適用範圍					
			壓力 (MPa)	速度 (m/s)	溫度 (°C)			
UIP		PU	40	0.5	-40~100	非對稱形狀之密封唇部設計，較短的內部密封唇部提供動態密封，而外部密封唇部則為靜態密封。	液壓	24-30
UIP2		PU	40	0.5	-40~100	非對稱形狀之密封唇部設計，較短的內部密封唇部提供動態密封，外部密封唇部則為靜態密封，第二唇可提供軸向穩定性。	液壓	31-41
UIP8		PU	40	0.5	-40~100	非對稱形狀之密封唇部設計，較短的內部密封唇部提供動態密封，外部密封唇部則為靜態密封，第二唇可提供軸向穩定性。	液壓	42
UNP2		PU	40	0.5	-40~100	密封唇部為對稱之形狀，內部密封唇部提供動態密封，而外部密封唇部則為靜態密封。第二唇可提供軸向穩定性。	液壓	43
CIP		PU	30	0.5	-40~100	非對稱形狀之密封唇部設計。較短的內部密封唇部提供動態密封，而外部密封唇部則為靜態密封。	液壓	44
UIB3		PU+PA	50	1	-40~100	非對稱形狀之密封唇部設計，內部較厚之密封唇部搭配背托環設計，提供較耐高壓的動態密封，外部密封唇部則為靜態密封。	液壓	45
HRO		PTFE+NBR PTFE+FKM	35	1.5	-35~100 -25~200	圓形環與鐵氟龍環兩件式組合之密封件設計，內部鐵氟龍環密封唇部提供動態密封，而外部圓形環則為靜態密封。	液壓	46





# 液/氣壓密封件的類型與特性

## 活塞桿(ROD)密封件

類型	剖面圖	使用條件				特性	應用環境	頁次
		材質	適用範圍					
			壓力 (MPa)	速度 (m/s)	溫度 (°C)			
UIR		NBR FKM	16	0.5	-35~100 -25~200	非對稱形狀之密封唇部設計，較短的內部密封唇部提供動態密封，而外部密封唇部則為靜態密封。	液/氣壓	47
CIR		NBR FKM	10	0.5	-35~100 -25~200	非對稱形狀之密封唇部設計，較短的內部密封唇部提供動態密封，而外部密封唇部則為靜態密封。	液/氣壓	48
LIR		NBR FKM	4	0.5	-35~100 -25~200	全橡膠材質之單一密封唇部設計。	液壓	49

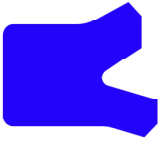
# 液/氣壓密封件的類型與特性

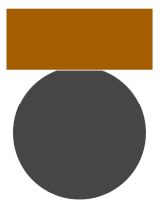
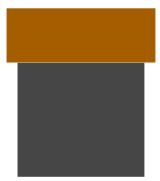



## 活塞(PISTON)密封件

類型	剖面圖	使用條件				特性	應用環境	頁次
		材質	適用範圍					
			壓力 (MPa)	速度 (m/s)	溫度 (°C)			
UOP		PU	40	0.5	-40~100	非對稱形狀之密封唇部設計。較短的外部密封唇部提供動態密封。而內部密封唇部則為靜態密封。	液壓	50-54
COP		PU	30	0.5	-40~100	非對稱形狀之密封唇部設計。較短的外部密封唇部提供動態密封。而內部密封唇部則為靜態密封。	液壓	55
HOD		PTFE+NBR+PA	50	1.5	-35~100	四件式組合之密封件設計，外部鐵氟龍環搭配背托環設計之密封唇部提供動態密封，而內部膠料彈性體則為靜態密封。	液壓	56
HPO		PTFE+NBR PTFE+FKM	35	1.5	-35~100 -25~200	圓形環與鐵氟龍環兩件式組合之密封件設計，外部鐵氟龍環密封唇部提供動態密封，而內部圓形環則為靜態密封。	液壓	57
HPS		PTFE+NBR PTFE+FKM	35	1.5	-35~100 -25~200	方型環與鐵氟龍環兩件式組合之密封件設計，外部鐵氟龍環密封唇部提供動態密封，而內部方型環則為靜態密封。	液壓	58
UOR		NBRFKM	16	0.5	-35~100 -25~200	非對稱形狀之密封唇部設計。較短的外部密封唇部提供動態密封。而內部密封唇部則為靜態密封。	液/氣壓	59
COR		NBR FKM	10	0.5	-35~100 -25~200	非對稱形狀之密封唇部設計。較短的外部密封唇部提供動態密封。而內部密封唇部則為靜態密封。	液/氣壓	60





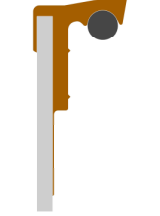
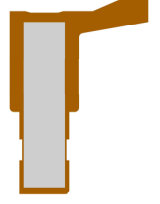

# 液/氣壓密封件的類型與特性

## 活塞(PISTON)密封件

類型	剖面圖	使用條件				特性	應用環境	頁次
		材質	適用範圍					
			壓力 (MPa)	速度 (m/s)	溫度 (°C)			
PDV		NBR FKM	1.2	1	-40~100 -25~200	比一般型的密封件更適於應用在高壓的環境。	氣壓	61
PDC		NBR FKM	6	0.5	-40~100 -25~200	適於應用在較高壓及低速之環境。在唇部上套有彈簧以加強唇部之密封性。	液壓	62
PDH		NBR FKM	6	0.5	-40~100 -25~200	適於應用在較高壓及低速之環境。其組成構造包含橡膠及鐵殼，並且在唇部上套有彈簧以加強唇部之密封性。	液壓	63
PSC		NBR FKM	6	0.5	-40~100 -25~200	適於應用在較高壓及低速之環境。在唇部上套有彈簧以加強唇部之密封性。	液壓	64
PSV		NBR FKM	1.2	1	-40~100 -25~200	適於應用在較高壓及低速之環境。其組成構造包含橡膠及鐵殼。	氣壓	65
PSV2		NBR FKM	1.2	1	-40~100 -25~200	適於應用在較高壓及低速之環境。其組成構造包含橡膠及鐵殼。	氣壓	66

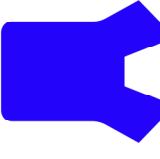

# 液/氣壓密封件的類型與特性

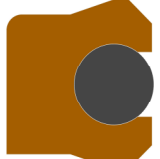
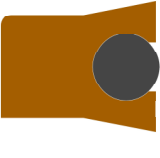
## 活塞桿(ROD)與活塞(PISTON)密封件

類型	剖面圖	使用條件				特性	應用環境	頁次
		材質	適用範圍					
			壓力 (MPa)	速度 (m/s)	溫度 (°C)			
UNP		PU	30	0.5	-40~100	對稱的密封唇設計，可應用於密封活塞及活塞桿。	液壓	67-79
UNP1		PU	40	0.5	-40~100	對稱的密封唇設計，可應用於密封活塞及活塞桿。	液壓	80-82
CNP		PU	20	0.5	-40~100	對稱的密封唇設計，可應用於密封活塞及活塞桿。	液壓	83
UNR		NBR FKM	16	0.5	-35~100 -25~200	對稱的密封唇設計，可應用於密封活塞及活塞桿。	液壓	84-86
CNR		NBR FKM	10	0.5	-35~100 -25~200	對稱的密封唇設計，可應用於密封活塞及活塞桿。	液壓	87
HB		對稱密封唇: PU 圓形環:NBR	35	0.5	-30~100	對稱的密封唇設計上加裝圓形環可提供更好的密封性在低壓力或無壓力時。可應用於高負載往復式運動環境中。	液壓	88-94
HD		對稱密封唇: PU 圓形環:NBR	35	0.5	-30~100	對稱的密封唇設計上加裝圓形環可提供更好的密封性在低壓力或無壓力時。可應用於高負載往復式運動環境中。	液壓	95-96



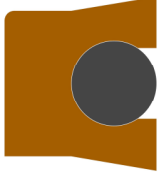



# 液/氣壓密封件的類型與特性

## 活塞桿(ROD)與活塞(PISTON)密封件

類型	剖面圖	使用條件				特性	應用環境	頁次
		材質	適用範圍					
			壓力 (MPa)	速度 (m/s)	溫度 (°C)			
HS		對稱密封唇: PU 圓形環:NBR	35	0.5	-30~100	對稱的密封唇設計上加裝圓形環可提供更好的密封性在低壓力或無壓力時。可應用於高負載往復式運動環境中。	液壓	97-99
HBX		對稱密封唇: PU 圓形環:NBR	35	0.5	-30~100	對稱的密封唇設計上加裝X型環可提供更好的密封性在低壓力或無壓力時。可應用於高負載往復式運動環境中。	液壓	100
HSX		對稱密封唇: PU 圓形環:NBR	35	0.5	-30~100	對稱的密封唇設計上加裝X型環可提供更好的密封性在低壓力或無壓力時。可應用於高負載往復式運動環境中。	液壓	101

# 液/氣壓密封件的類型與特性







## 防塵(WIPER)密封件

類型	剖面圖	使用條件				特性	應用環境	頁次
		材質	適用範圍					
			壓力 (MPa)	速度 (m/s)	溫度 (°C)			
WP1		PU	-	1	-40~100	全PU材質之雙密封唇部設計。	液壓	102-104
WP2		PU	-	1	-40~100	全PU材質之單一密封唇部設計。	液壓	105
WP3		PU	-	1	-40~100	組成構造包含PU材質及鐵殼，並且為單一密封唇部設計。	液壓	106-110
WP4		PU	-	1	-40~100	組成構造包含PU材質及鐵殼，並且為雙密封唇部設計。	液壓	111-112
WP5		PU	-	1	-40~100	組成構造包含PU材質及鐵殼，並且為單一密封唇部設計。	液壓	113-115
WP6		PU	-	1	-40~100	組成構造包含PU材質及鐵殼，並且為單一密封唇部設計。	液壓	116
WP7		PU	-	1	-40~100	組成構造包含PU材質及鐵殼，並且為單一密封唇部設計。	液壓	117









# 液/氣壓密封件的類型與特性

## 防塵(WIPER)密封件

類型	剖面圖	使用條件				特性	應用環境	頁次
		材質	適用範圍					
			壓力 (MPa)	速度 (m/s)	溫度 (°C)			
WP8		PU	-	1	-40~100	全PU材質之單一密封唇部設計。	液壓	118
WP10		PU	-	1	-40~100	全PU材質之雙密封唇部設計。	液壓	119
WP11		PU	-	1	-40~100	組成構造包含PU材質及鐵殼，並且為單一密封唇部設計。	液壓	120-121
WP16		PU	-	1	-40~100	組成構造包含PU材質及鐵殼，並且為單一密封唇部設計。	液壓	122
WP21		PU	-	1	-40~100	全PU材質之單一密封唇部設計。	液壓	123
WP22		PU	-	1	-40~100	全PU材質之單一密封唇部設計。	液壓	124
WP32		PU	-	1	-40~100	全PU材質之雙密封唇部設計。	液壓	125



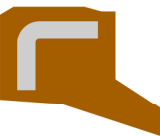



# 液/氣壓密封件的類型與特性

## 防塵(WIPER)密封件

類型	剖面圖	使用條件				特性	應用環境	頁次
		材質	適用範圍					
			壓力 (MPa)	速度 (m/s)	溫度 (°C)			
WPB		NBR FKM	-	1	-35~100 -25~200	組成構造包含橡膠材質及鐵殼，並且為單一密封唇部設計。	液/氣壓	126-127
WPC		NBR FKM	-	1	-35~100 -25~200	組成構造包含橡膠材質及鐵殼，並且為單一密封唇部設計。	液/氣壓	128
WPK		NBR FKM	-	1	-35~100 -25~200	組成構造包含橡膠材質及鐵殼，並且為雙密封唇部設計。	液/氣壓	129
WPM		NBR FKM	-	1	-35~100 -25~200	組成構造包含橡膠材質及鐵殼，並且為單一密封唇部設計。	液/氣壓	130-133
WPR		NBR FKM	-	1	-35~100 -25~200	組成構造包含橡膠材質及鐵殼，並且為單一密封唇部設計。	液/氣壓	134-135
WPV		NBR FKM	-	1	-35~100 -25~200	組成構造包含橡膠材質及鐵殼，並且為單一密封唇部設計。	液/氣壓	136
WP12		NBR FKM	-	1	-35~100 -25~200	全PU材質之單一密封唇部設計。	液/氣壓	137-138

# 液/氣壓密封件的類型與特性

## 防塵(WIPER)密封件

類型	剖面圖	使用條件				特性	應用環境	頁次
		材質	適用範圍					
			壓力 (MPa)	速度 (m/s)	溫度 (°C)			
WP13		NBR FKM	-	1	-35~100 -25~200	組成構造包含橡膠材質及鐵殼，並且為雙密封唇設計。	液/氣壓	139
WP14		NBR FKM	-	1	-35~100 -25~200	全橡膠材質之雙密封唇部設計。	液/氣壓	140
WP15		NBR FKM	-	1	-35~100 -25~200	全橡膠材質之單一密封唇部設計。	液/氣壓	141
WP17		NBR FKM	-	1	-35~100 -25~200	全橡膠材質之雙密封唇部設計。	液/氣壓	142
WP19		NBR FKM	-	1	-35~100 -25~200	全橡膠材質之單一密封唇部設計。	液/氣壓	143
WP24		NBR FKM	-	1	-35~100 -25~200	全橡膠材質之單一密封唇部設計。	液/氣壓	144
WPK1		NBR	-	1	-40~100	組成構造包含橡膠材質及鐵殼，並且為單一密封唇部設計。	液壓	145







## 液/氣壓密封件的類型與特性 防塵(WIPER)密封件

類型	剖面圖	使用條件				特性	應用環境	頁次
		材質	適用範圍					
			壓力 (MPa)	速度 (m/s)	溫度 (°C)			
WPK3		NBR	-	1	-40~100	組成構造包含橡膠材質及鐵殼，並且為單一密封唇部設計。增加刻齒設計幫助牛油灌注。	液壓	146



# 液/氣壓密封件的類型與特性

## 各種型環(RING)密封件

類型	剖面圖	使用條件				特性	應用環境	頁次
		材質	適用範圍					
			壓力 (MPa)	速度 (m/s)	溫度 (°C)			
O-ring		NBR FKM	10	-	-40~100 -25~200	圓形環為最廣泛使用之密封環，適用在靜態或低負載之動態環境。	液/氣壓	147-171
X-ring		NBR FKM	10	-	-40~100 -25~200	特殊之四唇設計，可以防止唇部在動態應用環境中產生不適當之扭轉，進而導致密封性失效。	液/氣壓	172-177
SQ-ring		NBR FKM	10	-	-40~100 -25~200	在高壓下，簡單的方形環設計使其為圓形環的良好替代物。低價位亦為其優點之一。	液/氣壓	178-180
D-ring		NBR FKM	10	-	-40~100 -25~200	D型設計可滿足特殊的溝槽形狀。	液/氣壓	181

NAK 標準型式

# UIP

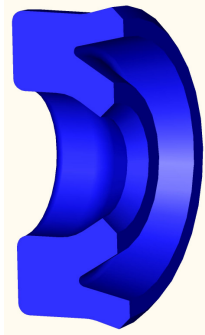
 應用環境：活塞桿(ROD)  
 材質：聚氨酯(PU)

**E1**

尺寸			單位	圖號
軸徑	孔徑	高度		
4	7	4.2	mm	U2686
4	9	3.5	mm	U3984
6	12	5.3	mm	U6824
6	13	5	mm	U2096
6	14	5.7	mm	U4460
8	14	4	mm	U2597
8	14	5	mm	U3540
8	16	4.5	mm	U1743
8	16	5.7	mm	U0122
8	16	8	mm	U4545
8	18	8	mm	U6880
9	14.5	5.7	mm	U7006
9.5	14	2.5	mm	U2007
9.9	20	4.5	mm	U7643
10	16	4.5	mm	U3440
10	16.8	4.5	mm	U1745
10	17	4.5	mm	U1371
10	18	5.7	mm	U2592
10	20	4.5	mm	U1746
10	20	6	mm	U7715
10	20	7.2	mm	U1132
10	20	8	mm	U6825
10	21	4.5	mm	U1736
11	19	6.3	mm	U0563
11.5	16	3.6	mm	U8226
12	17	3.5	mm	U7395
12	19	5.5	mm	U7200
12	20	5.7	mm	U3471
12	22	7.2	mm	U4553
12	22	8	mm	U2327
12.5	20	3	mm	U1734
12.5	21	4.6	mm	U1735
13	19	4	mm	U4062
14	18.3	3	mm	U7393
14	21	5	mm	U4618
14	22	5.7	mm	U3096

尺寸			單位	圖號
軸徑	孔徑	高度		
14	24	7.2	mm	U2594
14	24	8	mm	U4554
15	23	5.7	mm	U5146
15	25	8	mm	U4555
16	20.6	3.3	mm	U6889
16	22	5	mm	U2595
16	22	5.5	mm	U6827
16	23	4.5	mm	U8227
16	24	5.7	mm	U2190
16	24	6.2	mm	U6826
16	26	7.2	mm	U1439
16	26	8	mm	U3280
16	26	9	mm	U4556
18	24	4.7	mm	U6834
18	24	5	mm	U3447
18	26	5	mm	U5761
18	26	5.7	mm	U2119
18	26	8	mm	U3063
18	28	7.2	mm	U4208
18	28	8	mm	U4557
19	27	6	mm	U5871
20	26	5	mm	U1643
20	27	6	mm	U2054
20	28	5.7	mm	U2319
20	28	6.2	mm	U4558
20	28	7.2	mm	U6833
20	30	5.7	mm	U7550
20	30	7.2	mm	U2055
20	30	8	mm	U2426
20	30	10	mm	U1195
20	32	7.5	mm	U6914
20	35	10	mm	U6913
22	30	5.7	mm	U2160
22	30	7	mm	U3083
22	30	8	mm	U3064
22	32	7.2	mm	U3388

NAK 標準型式

# UIP

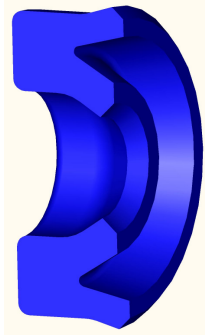
 應用環境：活塞桿(ROD)  
 材質：聚氨酯(PU)

尺寸			單位	圖號
軸徑	孔徑	高度		
22	32	8	mm	U3573
22	32	9	mm	U6912
22	32	10	mm	U6832
23	31	5	mm	U8248
24	34	7.2	mm	U6831
24	34	8.5	mm	U6830
25	32	5.7	mm	U5668
25	32	6	mm	U5567
25	33	5.7	mm	U2081
25	33	6.2	mm	U2520
25	33	7.2	mm	U2659
25	33	8	mm	U1835
25	33	10	mm	U1193
25	35	7.2	mm	U2258
25	35	8	mm	U3818
25	35	10	mm	U4559
25	38	9	mm	U6854
25	40	10	mm	U4560
28	36	5.7	mm	U2211
28	38	7.2	mm	U3013
28	38	8	mm	U3339
28	38	10	mm	U6853
28	40	8.5	mm	U6852
28	40	10	mm	U1836
28	43	11.5	mm	U4561
29	35	4.8	mm	U6851
30	38	5.7	mm	U2085
30	38	8	mm	U2122
30	38	5/7	mm	U6999
30	40	5.7	mm	U5719
30	40	7	mm	U2661
30	40	7.2	mm	U2077
30	40	9.5	mm	U5720
30	40	10	mm	U2328
30	42	8.5	mm	U8077
30	43	9	mm	U6926

尺寸			單位	圖號
軸徑	孔徑	高度		
30	45	8	mm	U6570
30	45	10	mm	U4562
30.95	45.24	10.31	mm	U2540
32	40	5.5	mm	U5758
32	40	5.7	mm	U2521
32	40	6	mm	U7379
32	40	8	mm	U2848
32	42	7	mm	U1837
32	42	7.2	mm	U2640
32	42	8	mm	U2542
32	42	10	mm	U3789
32	42.53	8.5	mm	U6192
32	45	9.5	mm	U6199
32	45	10	mm	U2017
32	47	10	mm	U3799
32	48	10	mm	U7375
33	43	10	mm	U6222
35	43	5.7	mm	U0013
35	43	8	mm	U2042
35	45	6	mm	U6221
35	45	7	mm	U3424
35	45	7.2	mm	U3196
35	45	10	mm	U3442
35	45	13	mm	U6226
35	46	8	mm	U6193
35	46	9	mm	U6194
35	47	8.5	mm	U6225
35	50	10	mm	U2459
35	55	12	mm	U5991
36	44	5.7	mm	U2515
36	44	8	mm	U6224
36	46	7.2	mm	U2609
36	46	10	mm	U3571
36	48	7.5	mm	U6223
36	48	8	mm	U2967
36	51	10	mm	U6227

E1

NAK 標準型式

# UIP



應用環境：活塞桿(ROD)  
材質：聚氨酯(PU)

E1

尺寸			單位	圖號
軸徑	孔徑	高度		
36	51	11.5	mm	U4563
37	45	5.7	mm	U6201
37	47	10	mm	U3426
38	44.5	4.8	mm	U6195
38	45	5	mm	U6200
38	45	6.2	mm	U6207
40	48	5.7	mm	U2044
40	48	8	mm	U1846
40	49.52	10	mm	U6202
40	50	6	mm	U6582
40	50	7.2	mm	U2949
40	50	8	mm	U1847
40	50	9	mm	U6206
40	50	10	mm	U3515
40	50	13.5	mm	U6214
40	52	8	mm	U2698
40	55	7.2	mm	U2707
40	55	9	mm	U6315
40	55	10	mm	U4207
40	55	11.5	mm	U3819
40	60	12	mm	U6213
42	50	5.7	mm	U7174
42	52	7	mm	U7245
42	62	10.5	mm	U6215
42	62	12	mm	U4841
42	62	12.5	mm	U6212
43	52.5	7.6	mm	U7751
44.40	54.03	6.53	mm	U7090
45	53	5.7	mm	U2102
45	53	8	mm	U3443
45	53	10	mm	U2212
45	53	12	mm	U4564
45	55	5.7	mm	U1848
45	55	5.8	mm	U1956
45	55	6	mm	U7094
45	55	6.2	mm	U5731

尺寸			單位	圖號
軸徑	孔徑	高度		
45	55	7.2	mm	U4565
45	55	7.3	mm	U3201
45	55	10	mm	U2193
45	57.7	9.5	mm	U3032
45	58	9	mm	U6129
45	60	10	mm	U2867
45	60	11.5	mm	U4566
45	65	10	mm	U6211
45	65	12	mm	U3522
45	65	13.5	mm	U6415
46	56	7.5	mm	U6216
47	56	9	mm	U3809
50	60	6	mm	U7368
50	60	6.4	mm	U5732
50	60	7.2	mm	U2681
50	60	8	mm	U6730
50	60	10	mm	U2194
50	60	12	mm	U6217
50	62	8	mm	U5990
50	62.7	10	mm	U6220
50	65	10	mm	U2460
50	65	11.4	mm	U3195
50	65	11.5	mm	U2593
50	68	9	mm	U6203
50	70	10	mm	U6219
50	70	12	mm	U2644
50.80	63.50	9.52	mm	U4507
51	61.4	6.4	mm	U6935
51	66	14	mm	U1787
52	62	10	mm	U3285
53.97	66.67	9.52	mm	U8086
55	63	8	mm	U2805
55	63	12	mm	U2298
55	65	6	mm	U7361
55	65	7.2	mm	U3281
55	65	7.3	mm	U3209



NAK 標準型式

# UIP



應用環境：活塞桿(ROD)  
材質：聚氨酯(PU)

尺寸			單位	圖號
軸徑	孔徑	高度		
55	65	10	mm	U3204
55	65	12	mm	U2682
55	65	13.5	mm	U6218
55	67	10	mm	U2165
55	68	10.5	mm	U6130
55	70	10	mm	U3574
55	70	12	mm	U2646
55	75	12	mm	U6249
55	75	13.5	mm	U6284
56	66	6	mm	U5290
56	66	10	mm	U3065
56	71	10	mm	U3066
56	71	11.5	mm	U2978
56	76	12	mm	U6283
56	76	13.5	mm	U6286
56	76	15	mm	U6285
57.15	69.85	9.52	mm	U0822
60	68	8	mm	U4819
60	68	11.5	mm	U0401
60	70	7.2	mm	U2635
60	70	10	mm	U4567
60	70	11.8	mm	U1153
60	70	12	mm	U2621
60	70	13	mm	U0786
60	72	8	mm	U6304
60	72	9	mm	U6303
60	73	10	mm	U7367
60	75	10	mm	U4528
60	75	11.5	mm	U3553
60	75	12	mm	U2132
60	77	11	mm	U6204
60	80	12	mm	U2849
60	80	13.5	mm	U6302
62	74	13	mm	U6888
63	73	10	mm	U6301
63	73	12	mm	U2683

尺寸			單位	圖號
軸徑	孔徑	高度		
63	75	8.7	mm	U2153
63	78	10	mm	U3189
63	78	11.5	mm	U2199
63	78	12	mm	U6247
63	83	12	mm	U2616
63	83	13.5	mm	U6246
63	83	15	mm	U4546
65	73	11.5	mm	U0399
65	75	10	mm	U2026
65	75	12	mm	U2113
65	75	13.5	mm	U6245
65	77	9	mm	U6208
65	78	10	mm	U3272
65	80	10	mm	U6242
65	80	12	mm	U3067
65	85	12	mm	U3832
65	85	13.5	mm	U6241
69.85	82.55	9.52	mm	U0824
70	80	6	mm	U7036
70	80	7	mm	U6619
70	80	7.2	mm	U2898
70	80	10	mm	U3302
70	80	12	mm	U2286
70	82	9	mm	U2259
70	83	10	mm	U6185
70	85	9	mm	U6838
70	85	10	mm	U2965
70	85	10.6	mm	U0044
70	85	11.5	mm	U3274
70	85	12	mm	U3206
70	88	13.5	mm	U4066
70	90	12	mm	U1849
70	90	15	mm	U3550
73	82.5	7.5	mm	U6205
75	85	6	mm	U7366
75	85	7.2	mm	U2878

E1

NAK 標準型式

# UIP

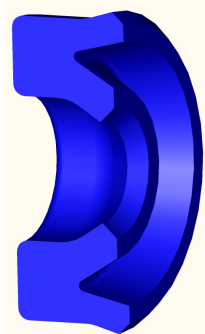
 應用環境：活塞桿(ROD)  
 材質：聚氨酯(PU)

**E1**

尺寸			單位	圖號
軸徑	孔徑	高度		
75	85	12	mm	U3157
75	87	8.6	mm	U1952
75	90	9	mm	U6551
75	90	10	mm	U2280
75	90	12	mm	U3055
75	95	12	mm	U6270
75	95	13.5	mm	U6269
76	84	7.5	mm	U6887
76	91	14	mm	U1788
76.2	92.07	9.52	mm	U6624
76.2	95.25	9.52	mm	U6622
80	90	7.2	mm	U4508
80	90	8	mm	U7360
80	90	10.5	mm	U3787
80	90	12	mm	U2070
80	90	14	mm	U6288
80	92	8.6	mm	U2128
80	93	10	mm	U3027
80	95	9	mm	U6552
80	95	10	mm	U2699
80	95	11.5	mm	U2733
80	95	12	mm	U2135
80	100	12	mm	U2398
80	100	13.5	mm	U0897
80	100	15	mm	U6287
82.55	95.25	9.52	mm	U3797
82.55	98.42	7.93	mm	U6635
85	95	7.2	mm	U6925
85	95	12	mm	U0198
85	97	8.7	mm	U3212
85	100	9	mm	U6547
85	100	10	mm	U7359
85	100	11	mm	U6924
85	100	11.5	mm	U1851
85	100	12	mm	U2710
85	105	12	mm	U6898

尺寸			單位	圖號
軸徑	孔徑	高度		
85	105	13.5	mm	U6886
87	95	11.5	mm	U0400
90	100	10	mm	U1839
90	100	11.5	mm	U6923
90	100	12	mm	U0587
90	102	9	mm	U1957
90	102	14	mm	U7854
90	105	8.5	mm	U1852
90	105	9	mm	U7358
90	105	10	mm	U2648
90	105	11.5	mm	U3014
90	105	12	mm	U2149
90	110	12	mm	U2450
90	110	15	mm	U3422
90	110	17	mm	U4068
91	99	8	mm	U6922
93	104	10.5	mm	U6921
95	105	10	mm	U6906
95	105	12	mm	U6930
95	110	9	mm	U3092
95	110	9.5	mm	U5721
95	110	12	mm	U2700
95	115	12	mm	U3111
98	112	8.5	mm	U7262
100	110	14	mm	U6929
100	113	13	mm	U6928
100	115	9	mm	U6398
100	115	10	mm	U6936
100	115	10.5	mm	U0866
100	115	11	mm	U2743
100	115	12	mm	U2649
100	120	11.5	mm	U3286
100	120	12	mm	U2850
100	120	13.5	mm	U6937
100	120	15	mm	U1840
100	125	19	mm	U6733

NAK 標準型式

# UIP

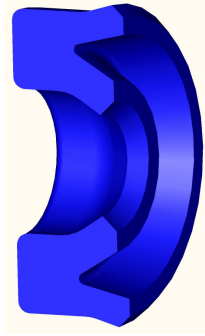

應用環境：活塞桿(ROD)  
材質：聚氨酯(PU)

尺寸			單位	圖號
軸徑	孔徑	高度		
105	115	10	mm	U6569
105	115	11.5	mm	U6932
105	115	13.5	mm	U6931
105	117	10	mm	U4581
105	120	9.9	mm	U5316
105	120	12	mm	U6938
105	120	15	mm	U5284
105	125	12	mm	U6248
110	120	12	mm	U3405
110	125	9	mm	U2864
110	125	9.6	mm	U1958
110	125	11	mm	U2637
110	125	12	mm	U0586
110	125	15	mm	U6849
110	130	12	mm	U3158
110	130	14.6	mm	U6885
110	130	15	mm	U2959
110	135	19	mm	U6939
115	130	9	mm	U7334
115	130	11	mm	U3556
115	135	12	mm	U6940
120	130	7.2	mm	U6918
120	130	11.5	mm	U1842
120	130	15	mm	U5603
120	132	10.5	mm	U6919
120	135	11.5	mm	U6902
120	135	15	mm	U5724
120	140	12	mm	U2525
120	140	14.6	mm	U3534
120	140	15	mm	U2346
125	135	13.5	mm	U6920
125	145	12	mm	U4082
125	145	15	mm	U2979
125	150	14	mm	U5980
125	150	19	mm	U6883
128	140	10	mm	U4139

尺寸			單位	圖號
軸徑	孔徑	高度		
130	140	7.2	mm	U6872
130	140	13.5	mm	U4525
130	145	12	mm	U3406
130	145	14	mm	U6873
130	145	15	mm	U7411
130	150	12	mm	U6281
130	150	15	mm	U3920
138	155	15	mm	U7780
140	150	11.5	mm	U5906
140	155	12	mm	U2990
140	160	12	mm	U4149
140	160	15	mm	U2131
140	165	19	mm	U6876
145	157.7	9	mm	U6882
150	160	13.5	mm	U4081
150	170	12	mm	U3301
150	170	13.5	mm	U1951
150	170	15	mm	U2966
152	164	10	mm	U4140
160	170	12	mm	U6875
160	180	12	mm	U6863
160	180	15	mm	U2141
160	185	15	mm	U1843
160	185	19	mm	U8258
160	190	18	mm	U6862
165	185	12	mm	U6190
6.500	7.500	0.750	inch	U5682
170	190	12	mm	U6865
170	190	15	mm	U2142
180	192	10	mm	U4141
180	200	12	mm	U6861
180	200	15	mm	U2140
180	200	19	mm	U6857
180	205	15	mm	U4547
180	205	18.2	mm	U7855
190	210	12.5	mm	U6860

E1





NAK 標準型式

# UIP2

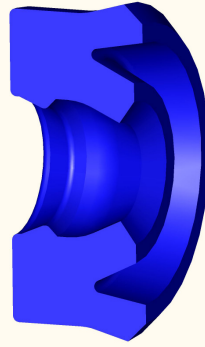
 應用環境：活塞桿(ROD)  
 材質：聚氨酯(PU)

尺寸			單位	圖號
軸徑	孔徑	高度		
4	12	6	mm	U0948
6	13	5	mm	U2941
6	14	5.5	mm	U3555
6	14	5.7	mm	U1441
8	16	5.5	mm	U0950
8	16	5.7	mm	U1442
8	18	8	mm	U1443
9.52	19.05	7.93	mm	U4346
0.375	0.625	0.210	inch	U7072
10	16	4.5	mm	U1744
10	18	5.5	mm	U0951
10	18	5.7	mm	U1598
10	18	8	mm	U3224
10	20	4.5	mm	U2939
10	20	7	mm	U1444
10	20	8	mm	U1445
10	22	7	mm	U3225
12	20	5.5	mm	U1597
12	20	5.7	mm	U3531
12	20	8	mm	U1446
12	22	5.5	mm	U7648
12	22	7.3	mm	U1595
12	22	8	mm	U3833
12.70	19.05	4.76	mm	U4112
0.500	0.750	0.210	inch	U7073
14	21	5.1	mm	U4696
14	22	5.5	mm	U1071
14	22	5.7	mm	U2974
14	24	7.3	mm	U1593
14	24	8	mm	U1448
14.28	20.63	4.76	mm	U4118
15	25	8	mm	U1449
15	25	10	mm	U3226
15	26	7.5	mm	U6179
15.4	25.5	6.5	mm	U6132
15.87	22.22	4.76	mm	U4113

尺寸			單位	圖號
軸徑	孔徑	高度		
15.87	25.40	7.14	mm	U4347
16	22	5	mm	U4416
16	24	5	mm	U7584
16	24	5.5	mm	U1072
16	24	5.8	mm	U1592
16	26	7	mm	U1591
16	26	7.3	mm	U1590
16	26	8	mm	U2980
16	28	8	mm	U1518
17	23	4	mm	U5199
17.46	23.81	4.76	mm	U4114
18	25	5	mm	U4050
18	26	5.5	mm	U1588
18	26	6	mm	U2903
18	26	6.3	mm	U4051
18	26	6.5	mm	U6133
18	26	8.5	mm	U6134
18	28	7	mm	U3227
18	28	7.3	mm	U1589
18	28	8	mm	U1450
19.05	25.40	4.76	mm	U4115
19.05	25.40	6.35	mm	U4103
0.750	1.000	0.250	inch	U6400
19.05	28.57	7.93	mm	U4348
19.5	27.5	8.5	mm	U6135
20	26	4.8	mm	U4052
20	28	5.5	mm	U2291
20	28	5.7	mm	U6959
20	30	6	mm	U7641
20	30	7	mm	U1622
20	30	7.3	mm	U5872
20	30	8	mm	U3228
20	30	10	mm	U5278
20	35	10	mm	U1073
20.63	26.98	4.76	mm	U4104
20.63	26.98	6.35	mm	U4105

E1

NAK 標準型式

# UIP2

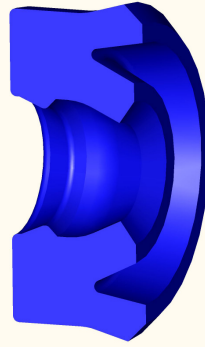
 應用環境：活塞桿(ROD)  
 材質：聚氨酯(PU)

**E1**

尺寸			單位	圖號
軸徑	孔徑	高度		
22	28	8	mm	U3229
22	30	5.7	mm	U2975
22	30	6	mm	U3917
22	32	6	mm	U6172
22	32	7.3	mm	U4154
22	32	8	mm	U3810
22	35	8	mm	U3231
22	35	10	mm	U3232
22.22	28.57	4.76	mm	U4106
22.22	28.57	6.35	mm	U4107
22.23	36	9.53	mm	U4202
23	35	10	mm	U1075
25	31	6	mm	U3724
25	32	10	mm	U1605
25	33	4.8	mm	U6125
25	33	5.5	mm	U2429
25	33	5.7	mm	U4382
25	33	6.5	mm	U2539
25	33	6.8	mm	U4383
25	33	7	mm	U6126
25	33	7.3	mm	U6186
25	33	10	mm	U4054
25	34	6.5	mm	U4628
25	35	7	mm	U3466
25	35	7.3	mm	U3016
25	35	8	mm	U2994
25	35	10	mm	U2660
25	38	10	mm	U3234
25	40	10	mm	U3834
25	43	6.5	mm	U3659
25	45	10	mm	U3235
25	45	12	mm	U0904
25.40	31.75	4.76	mm	U4108
1.000	1.250	0.250	inch	U5472
25.40	31.75	6.35	mm	U4109
25.40	34.92	6.35	mm	U4349

尺寸			單位	圖號
軸徑	孔徑	高度		
25.40	34.92	7.93	mm	U4350
25.4	38.1	9.52	mm	U4199
26	36	10	mm	U7130
26.98	33.34	4.76	mm	U4110
28	35.5	5.0	mm	U4820
28	36	7	mm	U2278
28	36	7.3	mm	U3572
28	38	7.3	mm	U3159
28	38	8	mm	U3786
28	38	10	mm	U4150
28	43	11.5	mm	U1078
28.57	34.92	4.76	mm	U4111
28.57	34.92	6.35	mm	U4116
28.57	38.10	7.93	mm	U4351
28.57	41.27	6.35	mm	U4675
1.125	1.375	0.250	inch	U5473
30	38	4.8	mm	U6127
30	38	5.7	mm	U5239
30	38	6	mm	U5279
30	38	6.3	mm	U5449
30	40	6.5	mm	U7048
30	40	7	mm	U6128
30	40	7.3	mm	U3264
30	40	8	mm	U3236
30	40	10	mm	U2215
30	45	10	mm	U3237
30	50	12	mm	U1079
30.16	39.68	6.35	mm	U4352
1.230	1.750	0.250	inch	U2657
1.250	1.500	0.187	inch	U6042
31.75	38.10	6.35	mm	U4097
1.250	1.500	0.250	inch	U5474
31.75	41.27	4.76	mm	U4680
31.75	41.27	6.35	mm	U4353
31.75	41.27	7.93	mm	U4354
1.250	1.625	0.187	inch	U6401

NAK 標準型式

# UIP2

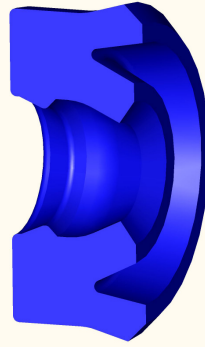
 應用環境：活塞桿(ROD)  
 材質：聚氨酯(PU)

尺寸			單位	圖號
軸徑	孔徑	高度		
1.250	1.625	0.375	inch	U7039
31.75	44.45	6.35	mm	U4674
31.75	44.45	9.52	mm	U4274
1.250	1.750	0.250/0.275	inch	U2538
32	40	6.7	mm	U2184
32	40	7.2	mm	U6018
32	40	8	mm	U2662
32	40	10	mm	U3238
32	41.5	7.2	mm	U5806
32	41.5	7.9	mm	U3283
32	42	7.3	mm	U2874
32	42	10	mm	U3508
32	45	8	mm	U3239
32	45	10	mm	U2163
32	47	10	mm	U4078
32	47	11.5	mm	U1081
34.92	41.27	6.35	mm	U4098
34.92	44.45	4.76	mm	U4679
34.92	44.45	7.93	mm	U4355
34.92	47.62	9.52	mm	U4275
1.375	1.750	0.187	inch	U6402
35	43	5.7	mm	U5528
35	43	7.2	mm	U5994
35	45	6	mm	U5611
35	45	7	mm	U3472
35	45	7.3	mm	U5560
35	45	8	mm	U4055
35	45	10	mm	U2924
35	50	10	mm	U3217
36	44	5.7	mm	U5559
36	44	6.3	mm	U4681
36	46	7	mm	U3084
36	46	7.3	mm	U3017
36	46	7.5	mm	U3420
36	46	10	mm	U2641
36	51	10	mm	U2879

尺寸			單位	圖號
軸徑	孔徑	高度		
36	56	12	mm	U3918
1.437	1.812	0.312	inch	U6403
36.51	46.04	7.93	mm	U4356
37	47	8	mm	U2111
37	47	10	mm	U5502
38	48	5.8	mm	U6609
38	48	8	mm	U4786
38	55	10	mm	U1083
38	58	10	mm	U3218
1.500	1.750	0.187	inch	U6043
38.10	44.45	6.35	mm	U4099
38.10	47.62	4.76	mm	U4678
38.10	47.62	6.35	mm	U4357
38.10	47.62	7.93	mm	U4358
38.1	47.62	9.52	mm	U7085
1.500	1.875	0.187	inch	U6404
38.1	50.8	6.35	mm	U4673
1.500	2.000	0.250	inch	U6405
38.1	50.8	9.52	mm	U4276
38.10	53.97	9.52	mm	U4335
1.500	2.125	0.375	inch	U6406
40	48	5.7	mm	U4057
40	48	8	mm	U3564
40	49.5	9.5	mm	U4056
40	50	7.3	mm	U2596
40	50	8	mm	U6610
40	50	10	mm	U2101
40	55	8	mm	U6611
40	55	10	mm	U3219
40	55	11.4	mm	U5532
40	55	11.5	mm	U1621
40	60	10	mm	U3220
40	60	11.5	mm	U5280
40	60	12	mm	U3240
41.27	47.62	6.35	mm	U4100
41.27	50.80	7.14	mm	U4421

E1

NAK 標準型式

# UIP2

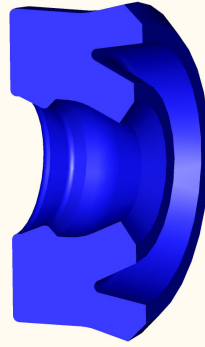
 應用環境：活塞桿(ROD)  
 材質：聚氨酯(PU)

E1

尺寸			單位	圖號
軸徑	孔徑	高度		
41.27	50.80	7.93	mm	U4422
41.27	50.80	9.52	mm	U4423
41.27	53.97	9.52	mm	U4284
1.625	2.125	0.375	inch	U6407
42	48	6	mm	U4430
42	50	5.7	mm	U6101
42	50	11.5	mm	U6001
42	52	10	mm	U3869
42	53	9	mm	U6022
44.45	50.80	6.35	mm	U4101
1.750	2.000	0.250	inch	U6408
44.45	53.97	6.35	mm	U4424
44.45	53.97	7.93	mm	U4432
44.45	53.97	9.52	mm	U4433
44.45	57.15	6.35	mm	U4672
1.750	2.250	0.250	inch	U6409
44.45	57.15	9.52	mm	U4285
44.45	57.15	12.7	mm	U4286
1.750	2.250	0.500	inch	U6410
1.750	2.254	0.394	inch	U5763
45	53	5.6	mm	U3561
45	53	6.3	mm	U8269
45	53	11.5	mm	U4039
45	55	7	mm	U1466
45	55	7.3	mm	U3197
45	55	10	mm	U1950
45	55	11.5	mm	U6002
45	57.7	9.5	mm	U1610
45	60	10	mm	U3241
45	60	11.5	mm	U3407
45	65	10	mm	U4058
45	65	12	mm	U1467
47	56	9	mm	U7250
47.62	57.15	9.52	mm	U4434
47.62	60.32	9.52	mm	U4287
1.875	2.375	0.375	inch	U6411

尺寸			單位	圖號
軸徑	孔徑	高度		
48	56	11.5	mm	U6003
48	56	12	mm	U6004
48	63	10	mm	U3276
48	68	12	mm	U1468
50	57	10	mm	U6021
50	58	6	mm	U7587
50	58	10	mm	U8155
50	58	11.5	mm	U6006
50	58	13	mm	U7059
50	60	7.3	mm	U2381
50	60	10	mm	U2256
50	62	10	mm	U1208
50	62.7	9.5	mm	U4041
50	63	10	mm	U3243
50	65	9.5	mm	U4042
50	65	10	mm	U2820
50	65	11	mm	U4040
50	65	11.5	mm	U3327
50	65	12	mm	U3244
50	65	15.5	mm	U3539
50	70	12	mm	U3631
50	70	14	mm	U6007
50.80	57.15	6.35	mm	U4102
50.80	60.32	6.35	mm	U4435
50.80	60.32	7.93	mm	U4436
50.8	60.32	9.52	mm	U4360
50.8	63.5	6.35	mm	U4676
2.000	2.500	0.250	inch	U6412
50.8	63.5	7.93	mm	U4288
50.8	63.5	9.52	mm	U4289
50.8	66.67	7.93	mm	U4670
50.80	66.67	12.7	mm	U4336
2.000	2.625	0.312	inch	U6439
50.8	69.85	15.87	mm	U4300
51	66	14	mm	U3245
52	62	10	mm	U1087

NAK 標準型式

# UIP2

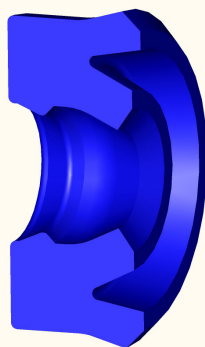
 應用環境：活塞桿(ROD)  
 材質：聚氨酯(PU)

尺寸			單位	圖號
軸徑	孔徑	高度		
53.97	63.50	9.52	mm	U4437
55	62.5	9	mm	U6020
55	63	11.5	mm	U6008
55	64	15	mm	U0858
55	65	6.7	mm	U7179
55	65	7.3	mm	U6960
55	65	9	mm	U6009
55	65	10	mm	U3575
55	65	12	mm	U2025
55	68	10	mm	U3926
55	70	9	mm	U5227
55	70	10	mm	U3427
55	70	12	mm	U2806
55	75	12	mm	U3246
56	66	7.3	mm	U6961
56	66	10	mm	U3836
56	71	10	mm	U3837
56	71	11.4	mm	U6957
56	71	11.5	mm	U2811
56	71	12.5	mm	U6544
56	76	12	mm	U0979
57	66	13	mm	U7681
57	70	10	mm	U3929
57.1	66.7	10	mm	U6079
57.1	69.8	10	mm	U6091
57.15	66.67	9.52	mm	U4446
57.15	69.85	9.52	mm	U4277
58	68	11.5	mm	U6019
60	68	6.3	mm	U8268
60	68	11.5	mm	U4053
60	68	13	mm	U3658
60	68	13.5	mm	U4156
60	70	7.5	mm	U4669
60	70	10	mm	U2321
60	70	11.5	mm	U4174
60	70	12	mm	U3085

尺寸			單位	圖號
軸徑	孔徑	高度		
60	72	10	mm	U2393
60	73	10	mm	U3925
60	75	9	mm	U5228
60	75	10	mm	U2708
60	75	11.4	mm	U5354
60	75	11.5	mm	U6024
60	75	12	mm	U2995
60	75	15.5	mm	U3808
60	80	10	mm	U4024
60	80	12	mm	U3203
60.32	69.85	9.52	mm	U4438
60.32	73.02	7.54	mm	U2546
60.32	73.02	9.52	mm	U4290
63	73	6	mm	U5229
63	73	12	mm	U2647
63	75	10	mm	U7017
63	78	10	mm	U3791
63	78	11.4	mm	U6956
63	78	11.5	mm	U1613
63	83	12	mm	U2891
63	83	13.5	mm	U0286
63.50	73.02	7.93	mm	U4401
63.50	73.02	9.52	mm	U4402
63.5	76.2	6.35	mm	U4677
63.5	76.2	9.52	mm	U3921
63.5	76.2	10	mm	U6088
63.50	79.37	12.7	mm	U4337
63.5	82.55	15.87	mm	U4301
64	72	10	mm	U8157
65	73	11.5	mm	U6023
65	73	13	mm	U3657
65	75	7	mm	U0450
65	75	10	mm	U6051
65	75	11.5	mm	U6045
65	75	12	mm	U2059
65	77.7	9.5	mm	U4043

E1



NAK 標準型式

# UIP2

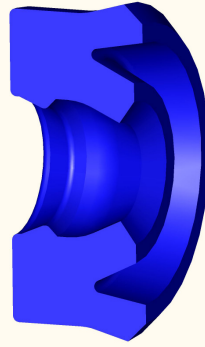
 應用環境：活塞桿(ROD)  
 材質：聚氨酯(PU)

**E1**

尺寸			單位	圖號
軸徑	孔徑	高度		
65	78	10	mm	U3557
65	80	9	mm	U5230
65	80	10	mm	U3247
65	80	12	mm	U2942
65	85	10	mm	U3248
65	85	12	mm	U3249
66	80	10.5	mm	U6057
66.67	76.20	9.52	mm	U4403
66.67	79.37	12.7	mm	U4291
66.67	82.55	15.87	mm	U4338
67	75	11.5	mm	U6046
67	75	13	mm	U7753
68	78	12	mm	U7352
68	80	10	mm	U6620
69.8	82.5	10	mm	U6058
69.85	79.37	9.52	mm	U4269
69.85	82.55	9.52	mm	U7546
69.85	85.72	9.52	mm	U4339
69.85	85.72	12.7	mm	U4340
69.85	85.73	12.7	mm	U1493
69.85	88.9	15.87	mm	U4302
70	77.5	9	mm	U6059
70	78	11.5	mm	U6047
70	78	12	mm	U1825
70	79	13	mm	U6060
70	79	15	mm	U0701
70	80	8	mm	U5669
70	80	10	mm	U3250
70	80	11.5	mm	U6048
70	80	12	mm	U2866
70	83	10	mm	U5037
70	85	10	mm	U3444
70	85	11.4	mm	U6955
70	85	11.5	mm	U2448
70	85	12	mm	U2412
70	85	13	mm	U3074

尺寸			單位	圖號
軸徑	孔徑	高度		
70	90	10	mm	U4025
70	90	12	mm	U3251
70	90	15	mm	U4173
70	90	18	mm	U3252
73	82.4	7.3	mm	U6080
73.02	82.55	9.52	mm	U4404
75	83	6.3	mm	U8267
75	83	11.5	mm	U3933
75	85	10	mm	U3253
75	85	10.5	mm	U6049
75	85	11.5	mm	U1599
75	85	12	mm	U3839
75	87	12.5	mm	U8170
75	90	9	mm	U5554
75	90	10	mm	U3254
75	90	12	mm	U2943
75	95	12	mm	U5038
76.20	85.72	9.52	mm	U4405
76.2	88.90	9.52	mm	U4292
76.2	88.9	10	mm	U6094
76.2	88.9	15.87	mm	U4293
76.2	92.07	12.7	mm	U4329
76.2	95.25	12.7	mm	U5893
76.2	95.25	15.87	mm	U4303
77	86	14	mm	U6090
78	86	10	mm	U8158
78	86	11.5	mm	U1482
78	86	13.5	mm	U6081
78	88	12	mm	U6053
78	88	14	mm	U7483
78	90	12.5	mm	U6093
79.37	88.90	15.87	mm	U4406
79.4	88.9	10	mm	U6089
80	88	11.5	mm	U6052
80	90	6	mm	U5238
80	90	11.5	mm	U8061

NAK 標準型式

# UIP2

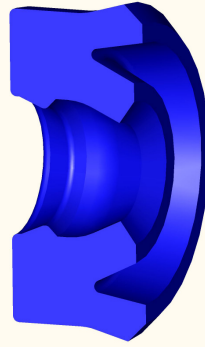
 應用環境：活塞桿(ROD)  
 材質：聚氨酯(PU)

尺寸			單位	圖號
軸徑	孔徑	高度		
80	90	12	mm	U2138
80	93	10	mm	U5237
80	95	9	mm	U5236
80	95	10	mm	U2715
80	95	11.4	mm	U6954
80	95	11.5	mm	U2892
80	95	12	mm	U2716
80	100	10	mm	U3255
80	100	12	mm	U3073
80	100	15	mm	U3042
82.5	97.5	12.5	mm	U6152
82.55	92.07	9.52	mm	U4407
82.55	92.07	14.28	mm	U4408
82.55	95.3	9.52	mm	U3840
82.55	98.42	12.7	mm	U4330
85	92.5	9	mm	U6173
85	93	10	mm	U5022
85	93	11.5	mm	U4044
85	94	15	mm	U7173
85	95	12.5	mm	U6543
85	100	9	mm	U5488
85	100	10	mm	U5240
85	100	11.4	mm	U5536
85	100	11.5	mm	U6153
85	100	12	mm	U2147
85	105	12	mm	U5552
86	98	10	mm	U6625
87	95	13	mm	U3656
87	96	13	mm	U7674
88.90	98.42	9.52	mm	U4409
88.9	101.6	7.93	mm	U4294
88.9	101.6	9.52	mm	U4193
88.9	101.6	10	mm	U6174
88.90	104.77	12.7	mm	U4315
88.9	107.95	15.87	mm	U4304
88.90	107.95	15.9	mm	U1492

尺寸			單位	圖號
軸徑	孔徑	高度		
90	98	11.5	mm	U6154
90	98	12	mm	U1826
90	100	6	mm	U7586
90	100	7.5	mm	U6155
90	100	9	mm	U6156
90	100	10	mm	U4096
90	100	11.5	mm	U3103
90	100	12	mm	U3623
90	102	12	mm	U7062
90	105	10	mm	U5039
90	105	11.5	mm	U2737
90	105	12	mm	U2322
90	110	10	mm	U4027
90	110	12	mm	U2738
92.07	104.77	9.52	mm	U4194
93	101	10	mm	U8159
93	101	11.5	mm	U6120
95	103	11.5	mm	U6121
95	105	9	mm	U6136
95	105	11.5	mm	U8060
95	105	12	mm	U3510
95	107	12.5	mm	U8171
95	110	9	mm	U5241
95	110	10	mm	U5242
95	115	12	mm	U2739
95.25	104.77	9.52	mm	U4410
95.25	107.95	9.52	mm	U4195
95.25	107.95	12.7	mm	U4196
95.25	107.95	14.28	mm	U4197
3.750	4.250	0.570	inch	U5197
96	104	12	mm	U7520
97	105	11.5	mm	U6150
97	105	13.5	mm	U6151
97	106	14	mm	U6175
97	107	15	mm	U7482
99	109	12.5	mm	U6141

E1

NAK 標準型式

# UIP2

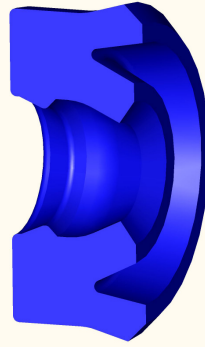
 應用環境：活塞桿(ROD)  
 材質：聚氨酯(PU)

**E1**

尺寸			單位	圖號
軸徑	孔徑	高度		
99	109	14	mm	U6990
100	108	11.5	mm	U6142
100	108	12	mm	U3072
100	109	15	mm	U5524
100	110	10.5	mm	U6177
100	110	11.30	mm	U0622
100	110	11.5	mm	U6143
100	110	14	mm	U4091
100	112	14	mm	U7233
100	115	9	mm	U5252
100	115	10	mm	U5457
100	115	11.4	mm	U5515
100	115	12	mm	U2257
100	120	12	mm	U2336
100	120	14.5	mm	U3936
100	120	14.6	mm	U6958
100	120	15	mm	U3636
100	125	15	mm	U3214
101.6	111.12	9.52	mm	U4198
101.6	114.3	7.93	mm	U4278
101.6	114.3	9.52	mm	U4279
101.6	114.3	14.28	mm	U4280
101.60	117.47	9.52	mm	U4331
101.60	117.47	12.7	mm	U4332
101.6	120.65	12.7	mm	U4295
101.6	120.65	15.87	mm	U4296
105	113	11.5	mm	U6144
105	113	13.5	mm	U6145
105	115	11.5	mm	U4341
105	120	9.9	mm	U2740
105	125	10	mm	U3215
105	125	15	mm	U3216
106	118	10	mm	U6626
107.95	127	15.87	mm	U4297
110	118	10	mm	U8160
110	118	11.5	mm	U6146

尺寸			單位	圖號
軸徑	孔徑	高度		
110	120	11.5	mm	U8164
110	120	12	mm	U2893
110	125	9	mm	U5253
110	125	12	mm	U5281
110	125	15	mm	U3256
110	130	10	mm	U5042
110	130	12	mm	U2825
110	130	13	mm	U5254
110	130	14.5	mm	U2575
110	130	15	mm	U3043
110	135	15	mm	U4045
112	121	13	mm	U7668
112	122	10.5	mm	U6158
112	125	15	mm	U7063
113	123	9	mm	U6159
4.500	4.875	0.375	inch	U7041
114.3	127	9.52	mm	U4281
114.3	127	12.7	mm	U5894
114.30	130.17	12.7	mm	U4333
114.30	130.17	15.87	mm	U4334
114.3	133.35	15.87	mm	U4298
115	123	11.5	mm	U6182
115	124	15	mm	U5529
115	125	12	mm	U1067
115	125	14	mm	U6160
115	130	10.5	mm	U6161
115	130	15	mm	U3257
115	140	15	mm	U1068
116	126	11.5	mm	U8063
116	126	15	mm	U7481
117	126	14	mm	U6178
117	131	12.5	mm	U8172
117.47	133.35	15.87	mm	U4342
118	126	13.5	mm	U2116
118	133	9	mm	U5456
120	128	11.5	mm	U6866

NAK 標準型式

# UIP2

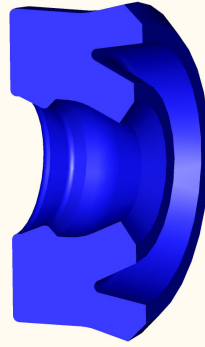
 應用環境：活塞桿(ROD)  
 材質：聚氨酯(PU)

尺寸			單位	圖號
軸徑	孔徑	高度		
120	130	11.50	mm	U0625
120	130	12	mm	U6162
120	130	14	mm	U3654
120	135	9	mm	U5454
120	135	15	mm	U4142
120	140	12	mm	U3188
120	140	14.6	mm	U5514
120	140	15	mm	U2735
120.65	130.17	9.52	mm	U4411
120.65	130.17	15.87	mm	U4400
121	135	9	mm	U6187
125	133	11.5	mm	U6157
125	135	10	mm	U6169
125	135	13.5	mm	U4092
125	137	14	mm	U7232
125	145	12	mm	U3841
125	145	14.6	mm	U5513
125	145	15	mm	U2200
125	150	15	mm	U3258
125	155	18	mm	U2201
5.000	5.375	0.375	inch	U7040
127	139.7	9.52	mm	U4282
127	139.7	14.28	mm	U4283
127	142.87	12.7	mm	U4344
127	146.05	15.87	mm	U4299
128	136	11.5	mm	U6170
128	140	10	mm	U6627
129	137	10	mm	U8161
129	139	11.5	mm	U8165
130	138	11.5	mm	U6171
130	140	11.5	mm	U7345
130	140	13.5	mm	U4093
130	145	12	mm	U7499
130	150	12	mm	U3919
130	150	15	mm	U3259
130.17	142.87	14.28	mm	U4317

尺寸			單位	圖號
軸徑	孔徑	高度		
130.17	152.4	12.7	mm	U4345
131	150	13	mm	U6188
132	142	8.7	mm	U3986
132	142	15	mm	U0859
5.250	5.750	0.570	inch	U5200
133.35	146.05	15.7	mm	U7512
135	143	11.5	mm	U6164
135	145	11.5	mm	U8037
135	145	12	mm	U7504
135	145	15	mm	U7480
135	148	15	mm	U7064
135	150	11.5	mm	U4047
135	150	15	mm	U6165
136.52	149.22	15.87	mm	U4318
136.52	152.40	15.87	mm	U4343
137	146	14	mm	U6189
139.70	152.40	9.52	mm	U4320
139.70	152.40	14.28	mm	U4319
139.70	155.57	7.93	mm	U4671
139.7	158.75	15.87	mm	U4305
140	148	11.5	mm	U6166
140	150	11.5	mm	U4527
140	150	12	mm	U3655
140	155	12	mm	U0624
140	160	12	mm	U3842
140	160	14.6	mm	U5537
140	160	15	mm	U2204
140	165	15	mm	U2205
140	170	18	mm	U1125
141	151	12.5	mm	U6167
141	151	14	mm	U6989
142	156	12.5	mm	U8173
142.87	155.57	9.52	mm	U4321
143	151	11.5	mm	U6881
143	151	13.5	mm	U4159
145	153	11.5	mm	U8102

E1

NAK 標準型式

# UIP2

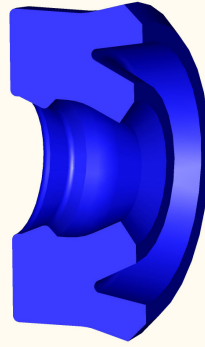
 應用環境：活塞桿(ROD)  
 材質：聚氨酯(PU)

**E1**

尺寸			單位	圖號
軸徑	孔徑	高度		
145	155	12.5	mm	U6237
145	160	12	mm	U6168
149	159	11.5	mm	U8166
150	160	13.5	mm	U4094
150	160	15	mm	U5530
150	162	14	mm	U7231
150	170	14.5	mm	U4048
150	170	15	mm	U2894
150	180	15	mm	U3260
150	180	18	mm	U1502
151	159	10	mm	U8162
152	167	12	mm	U6628
152.40	165.10	14.28	mm	U4322
152.4	171.45	15.87	mm	U4306
154	164	11.5	mm	U8015
155	165	11.5	mm	U7347
155	165	15	mm	U7484
160	168	11.5	mm	U0471
160	170	11.5	mm	U5012
160	170	12	mm	U6719
160	175	18	mm	U7065
160	180	15	mm	U3261
160	185	15	mm	U1116
160	185	18.2	mm	U1503
160	190	18	mm	U2919
162	172	14	mm	U6985
165	185	12	mm	U5035
165.1	184.15	15.87	mm	U4307
6.500	7.500	0.750	inch	U5085
169	179	11.5	mm	U8167
170	180	15	mm	U7012
170	190	15	mm	U2072
170	200	18	mm	U1114
171	179	13.5	mm	U4169
6.750	7.250	0.570	inch	U5198
171.45	184.15	15.7	mm	U7449

尺寸			單位	圖號
軸徑	孔徑	高度		
175	185	11.5	mm	U7977
175	185	12	mm	U7498
175	187	15	mm	U7234
176	186	10	mm	U8163
177.80	190.50	14.28	mm	U4326
177.8	196.85	15.87	mm	U4308
7.000	8.000	0.750	inch	U5156
180	190	10	mm	U4170
180	190	11.5	mm	U7346
180	192	14	mm	U6736
180	195	12.5	mm	U7469
180	200	15	mm	U1505
180	205	15	mm	U2915
180	205	19	mm	U2767
180	210	18	mm	U1506
183	193	14	mm	U6988
185	195	12	mm	U7964
185	195	13.5	mm	U7669
185	197	15	mm	U7091
190.50	203.20	9.52	mm	U4325
191	201	11.5	mm	U8168
196	206	15	mm	U7475
196.85	215.90	15.87	mm	U4309
197	207	11.5	mm	U7967
200	212	12	mm	U7500
200	220	15	mm	U2987
200	225	16	mm	U5036
200	225	19	mm	U1119
200	230	18	mm	U1508
203.20	215.90	9.52	mm	U4323
203.20	215.90	14.28	mm	U4324
203.2	222.25	15.87	mm	U4310
205	220	12.5	mm	U4049
207	217	14	mm	U6987
210	225	18	mm	U6737
210	230	15	mm	U2988



NAK 標準型式

# UIP2

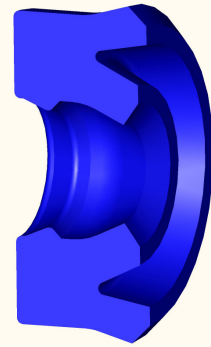

應用環境：活塞桿(ROD)  
材質：聚氨酯(PU)

尺寸			單位	圖號
軸徑	孔徑	高度		
210	240	18	mm	U1121
212	222	12	mm	U7963
214	224	11.5	mm	U8169
215.90	228.60	9.52	mm	U4327
220	250	18	mm	U1120
228.6	241.30	14.28	mm	U4328

尺寸			單位	圖號
軸徑	孔徑	高度		

E1



NAK 標準型式

# UNP2

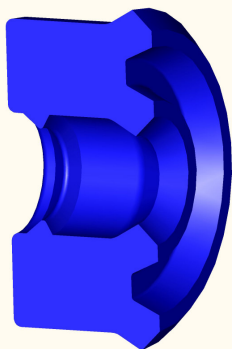

應用環境：活塞桿(ROD)  
材質：聚氨酯(PU)

尺寸			單位	圖號
軸徑	孔徑	高度		
8	16	5.7	mm	U7675
13	24	6	mm	U6560
18	26	5.8	mm	U3640
20	28	5.8	mm	U6096
22	30	5.8	mm	U7122
22	30	7	mm	U6099
25	32	6	mm	U2238
25	33	5.8	mm	U2970
25	33	6.5	mm	U6945
25	35	7	mm	U0494
28	38	7	mm	U3552
30	38	7	mm	U5512
30	38	8	mm	U2185
30	40	10	mm	U0493
32	42	7	mm	U2652
35	45	10	mm	U0492
36	44	8	mm	U3582
37	47	7	mm	U1018
38.1	47.6	9.5	mm	U0661
40	48	5.4	mm	U2992
40	48	6	mm	U2960
40	48	6.3	mm	U2642
40	48	8	mm	U5309
40	50	7	mm	U2653
40	52	8	mm	U1946
42	52	8	mm	U8310
45	53	8	mm	U2651
45	55	5.8	mm	U3835
45	55	7	mm	U4583
45	55	10	mm	U5311
50	58	8	mm	U3351
50	60	7	mm	U3147
50	60	7.3	mm	U7800
50	60	10	mm	U0490
55	63	8	mm	U6986
57	65	8	mm	U2788

尺寸			單位	圖號
軸徑	孔徑	高度		
60	68	6.3	mm	U7377
60	75	10	mm	U3563
62	67.5	5	mm	U7740
65	73	8	mm	U3533
70	80	12	mm	U2612
75	83	6.3	mm	U7380
76.2	88.9	9.52	mm	U2890
78	90	12	mm	U7464
82	94	8	mm	U7463
85	93	6.3	mm	U7371
85	93	8	mm	U4171
90	98	6.3	mm	U7372
100	110	12	mm	U7253
100	115	11.5	mm	U4924
100	115	12	mm	U2417
104	116	8	mm	U7319
105	113	6.3	mm	U7376
129	141	8	mm	U7318
154	166	10	mm	U7307
180	192	10	mm	U7313
210	222	13	mm	U7506

E1

NAK 標準型式

# CIP

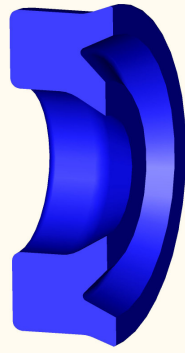

應用環境：活塞桿(ROD)  
 材質：聚氨酯(PU)

E1

尺寸			單位	圖號
軸徑	孔徑	高度		
14	20	3.5/4	mm	U0410
38	46	11.3	mm	U6828

尺寸			單位	圖號
軸徑	孔徑	高度		

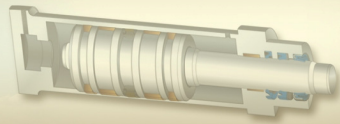

NAK 標準型式

# UIB3

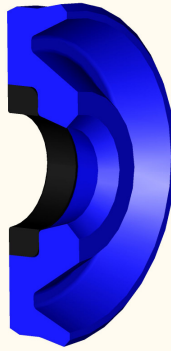

應用環境：活塞桿(ROD)  
材質：聚氨酯(PU)，尼龍(PA)

尺寸			單位	圖號
軸徑	孔徑	高度		
40	55.5	6	mm	U6760
50	65.5	6	mm	U6761
75	90.5	6	mm	U6762
80	95.5	6	mm	U6657
95	110.5	6	mm	U5722
100	115.5	6	mm	U6763
120	135.5	6	mm	U6658
130	145.5	6	mm	U5698
135	150.5	6	mm	U6764
150	165.5	6	mm	U6659
180	195.5	6	mm	U6765

尺寸			單位	圖號
軸徑	孔徑	高度		

E1

NAK 標準型式

# HRO



應用環境：活塞桿(ROD)  
 材質：聚四氟乙烯(PTFE)  
 丁腈橡膠(NBR)  
 氟素橡膠(FKM)

**E1**

尺寸			單位	圖號
軸徑	孔徑	高度		
30	39	3.8	mm	U6785
90	105	6.3	mm	U6788
50	65	6.3	mm	U6840

尺寸			單位	圖號
軸徑	孔徑	高度		



NAK 標準型式

# UJR



應用環境：活塞桿(ROD)  
 材質：丁腈橡膠(NBR)  
 氟素橡膠(FKM)

尺寸			單位	圖號
軸徑	孔徑	高度		
3	6.5	3	mm	U7178
3	7	3	mm	U5118
6	12	3.5	mm	U7454
6.35	12.7	3.96	mm	U7467
9.5	14	2.5	mm	U2008
10	15	3.5	mm	U8279
10	16	4	mm	U0640
10	18	5	mm	U8147
12.75	19.2	3.8	mm	U8280
14	18.3	3	mm	U8176
15.87	22.22	4.76	mm	U7472
16	22.4	3.2	mm	U7299
16	24	6.5	mm	
16	26	5.7	mm	U5477
17	27.8	6.2	mm	U7777
17	28	6.2	mm	U7580
17.46	23.8	4.5	mm	U7473
18	24	4.6	mm	U7474
18	25	6	mm	U5129
20	30	10	mm	RD064
25	34	5.2	mm	U7116
25	35	7	mm	U8088
25.4	35	6.5	mm	U5903
25.4	38.1	6.35	mm	U7615
27	35	5.2	mm	U7281
28	36	4	mm	U0711
28	38	7	mm	U7616
30	36	5	mm	U1109
32	40	4.5	mm	U7046
33	40.5	5	mm	U7720
33.34	40.63	4.6	mm	U7617
33.5	40	5	mm	U6995
34.7	44	6	mm	U7716
35	44	5	mm	U2837
35	45	6.5	mm	U5999
35	46	6.8	mm	U7696

尺寸			單位	圖號
軸徑	孔徑	高度		
35	46	7	mm	U7695
36	46	6.2	mm	U7274
38	47.7	6.5	mm	U7143
39	49	6	mm	U7694
40	50	7	mm	U6732
40	51	7	mm	U7697
44	55	11.5	mm	U7283
45	56	7	mm	U7712
47.63	63.5	9.52	mm	U7468
48	58	7	mm	U7034
50	57	5.3	mm	U7851
63.5	76.2	7.92	mm	U7630
90	102	8.5	mm	U7414

E1

NAK 標準型式

# CIR



應用環境：活塞桿(ROD)  
 材質：丁腈橡膠(NBR)  
 氟素橡膠(FKM)

E1

尺寸			單位	圖號
軸徑	孔徑	高度		
7.9	13.5	3	mm	U7714
7.93	14.28	3.25	mm	U4365
12	18	5	mm	U7476
12	20	5	mm	U4364
14	22	5	mm	U7477
14	22	6	mm	U4366
18	25	4.5	mm	U4367
20	28	5.5	mm	U4415
25	33	5	mm	U7045
33.5	44	6	mm	U7276
34	44	6	mm	U7044

尺寸			單位	圖號
軸徑	孔徑	高度		

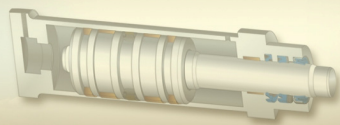

NAK 標準型式

# LIR

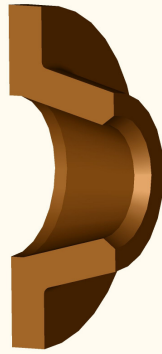

應用環境：活塞桿(ROD)  
 材質：丁腈橡膠(NBR)  
 氟素橡膠(FKM)

尺寸			單位	圖號
軸徑	孔徑	高度		
11	18	2/5	mm	U6119

尺寸			單位	圖號
軸徑	孔徑	高度		

E1

NAK 標準型式

# UOP

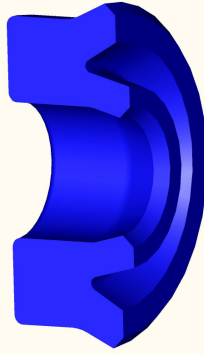
 應用環境：活塞(PISTON)  
 材質：聚氨酯(PU)

E2

尺寸			單位	圖號
軸徑	孔徑	高度		
5	12	5.5	mm	U6209
6	10	4.2	mm	U2685
6	10	4.5	mm	U3581
8	14	5.7	mm	U3509
8	14	6.3	mm	U6210
8	16	5.8	mm	U7699
0.375	0.750	0.312	inch	U6432
10	15.5	4.1	mm	U4823
10	16	4.5	mm	U4575
10	16	8	mm	U6183
10	20	7.5	mm	U2267
10	20	8	mm	U2399
10	25	10	mm	U6240
12	18	5.1	mm	U4822
12	20	6.5	mm	U6234
12	22	8	mm	U2422
14	20	5.5	mm	U6252
15	25	7.3	mm	U2423
15	25	8	mm	U2189
15	30	10	mm	U2424
16	24	5.7	mm	U4014
17	25	5.5	mm	U2425
19.05	28.57	7.93	mm	U4732
20	30	8	mm	U2802
20	35	10	mm	U6232
20	44	11	mm	U6321
20.63	30.16	6.35	mm	U7849
21	37	12	mm	U2167
22	30	6.5	mm	U2445
22	30	6.65	mm	U8149
22	32	7.3	mm	U2427
22	32	8	mm	U6239
22	32	10	mm	U5159
22	34	8.7	mm	U6243
22	34	9	mm	U6233
22	42	10	mm	U3299

尺寸			單位	圖號
軸徑	孔徑	高度		
24	32	5.5	mm	U4709
24	32	5.7	mm	U2428
24	36.5	6.5	mm	U6306
24	40	9	mm	U2790
25	35	7.3	mm	U2430
25	35	8	mm	U6231
25	40	9	mm	U2431
25	40	10	mm	U2191
25	43	9	mm	U6322
25	45	12	mm	U2433
26	32	5	mm	U6238
27	35	5	mm	U7835
27	35	10	mm	U6230
28	40	10	mm	U2434
28.5	45	12	mm	U6320
28.57	38.1	6.35	mm	U4733
1.125	1.500	0.250	inch	U6433
30	38	6.5	mm	U5205
30	38.1	6	mm	U4804
30	39	6.5	mm	U2969
30	40	6	mm	U7381
30	40	6.5	mm	U6300
30	40	7	mm	U2268
30	40	8	mm	U7374
30	40	10	mm	U2269
30	43	10	mm	U4788
30	45	10	mm	U6310
30	50	12	mm	U2435
31	38	4.7	mm	U6305
31.75	38.1	6.35	mm	U4734
32	40	5.7	mm	U3012
32	40	8	mm	U6299
32	42	10	mm	U6298
32	50	10	mm	U6450
33	40	8	mm	U2079
33	43	7.3	mm	U2270

NAK 標準型式

# UOP

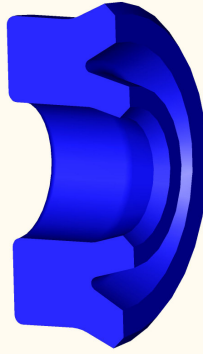
 應用環境：活塞(PISTON)  
 材質：聚氨酯(PU)

尺寸			單位	圖號
軸徑	孔徑	高度		
34	50	12	mm	U5637
34.5	42	3.7	mm	U6297
34.92	50.8	12.7	mm	U4735
35	45	6	mm	U5134
35	50	8.5	mm	U6451
35	50	10	mm	U3876
35	55	12	mm	U2436
37	45	9	mm	U8288
38.1	50.8	9.52	mm	U4736
39.5	55	10	mm	U8070
40	50	7	mm	U2271
40	50	10	mm	U2100
40	55	10	mm	U6746
40	60	12	mm	U2437
40	60	13.5	mm	U6452
40	62	15.2	mm	U0660
40.8	50.8	7.5	mm	U6735
41.27	50.8	4.76	mm	U4728
41.27	50.8	7.93	mm	U4729
41.27	50.8	9.52	mm	U4730
41.27	63.5	12.7	mm	U4724
1.625	2.500	0.500	inch	U6430
42	50	5.5	mm	U6454
42	50	8	mm	U2614
42	50	10	mm	U6453
42	52	10	mm	U6734
43	63	12	mm	U5161
44	54	7.3	mm	U2272
44.45	57.15	9.52	mm	U4731
1.750	2.250	0.375	inch	U6431
45	55	6	mm	U7373
45	55	10	mm	U6745
45	56	7	mm	U2821
45	60	10	mm	U2663
45	63	10	mm	U6738
45	63	12	mm	U3002

尺寸			單位	圖號
軸徑	孔徑	高度		
45	65	12	mm	U6739
46	56	6	mm	U6972
47	55	4.8	mm	U6879
47	55	5.7	mm	U6744
47.62	57.15	9.52	mm	U4723
47.62	63.5	12.7	mm	U4725
1.875	2.500	0.500	inch	U6429
48	63	9	mm	U2279
48	63	11.4	mm	U2276
48	63	12	mm	U2038
48	68	10	mm	U6747
50	60	6	mm	U7369
50	60	7	mm	U2277
50	60	8	mm	U5160
50	60	10	mm	U2323
50	65	11.5	mm	U6106
50	70	13.5	mm	U6030
50	70	15	mm	U6743
50	75	14	mm	U6796
50.8	63.5	6.35	mm	U4726
50.8	63.5	9.52	mm	U4727
52	60	8	mm	U6741
53	63	4.25	mm	U5774
53	63	7	mm	U2105
53	63	12	mm	U2395
53.97	63.5	6.35	mm	U4714
53.97	63.5	7.93	mm	U4715
53.97	63.5	9.52	mm	U4716
53.98	69.85	7.93	mm	U6969
54	60	6	mm	U5009
55	63	5.7	mm	U2282
55	65	7.3	mm	U2283
55	65	10	mm	U6740
55	70	9	mm	U7378
55	70	9.5	mm	U6758
55	70	10	mm	U4010

E2

NAK 標準型式

# UOP

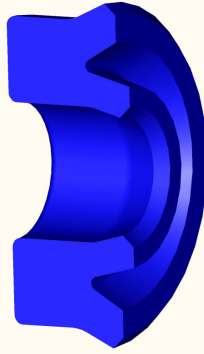
 應用環境：活塞(PISTON)  
 材質：聚氨酯(PU)

E2

尺寸			單位	圖號
軸徑	孔徑	高度		
55	70	12	mm	U2803
55	75	12	mm	U2400
55	75	13.5	mm	U6801
57	67	7.3	mm	U2281
58	72	12	mm	U6795
60	70	6	mm	U4874
60	70	7	mm	U6759
60	70	8	mm	U4011
60	70	12	mm	U2804
60	70	13.5	mm	U6793
60	75	12	mm	U2401
60	80	12	mm	U3156
60	80	14.5	mm	U2402
60.32	76.2	12.7	mm	U4721
61	71	6	mm	U4012
61	71	6.5	mm	U5501
62	70	7.5	mm	U6794
63	73	6	mm	U7331
63.5	76.2	6.35	mm	U4722
2.500	3.000	0.250	inch	U6428
63.5	76.2	9.52	mm	U4737
2.500	3.000	0.375	inch	U5726
65	75	7.2	mm	U6996
65	75	11.5	mm	U1531
65	75	13.5	mm	U6414
65	80	8.6	mm	U7743
65	80	11.4	mm	U2732
65	80	12	mm	U3872
65	85	10	mm	U3674
65	85	13.5	mm	U6802
65	90	12	mm	U3004
66.67	76.2	9.52	mm	U4738
66.67	82.55	12.7	mm	U4739
2.625	3.250	0.500	inch	U6427
69.85	82.55	6.35	mm	U4740
2.750	3.250	0.250	inch	U6426

尺寸			單位	圖號
軸徑	孔徑	高度		
69.85	82.55	9.52	mm	U4741
2.750	3.250	0.375	inch	U6425
69.85	88.90	12.70	mm	U4635
69.85	88.90	15.87	mm	U4636
70	80	6	mm	U4978
70	80	6.7	mm	U2403
70	80	7	mm	U3547
70	80	8	mm	U4620
70	80	12	mm	U2636
70	85	12	mm	U3003
70	90	12	mm	U3284
70	90	13.5	mm	U6808
71	80	6	mm	U7370
2.812	3.250	0.250	inch	U6756
72	80	12	mm	U2067
73.02	82.55	6.35	mm	U4742
73.02	88.90	7.93	mm	U4776
73.02	88.9	12.7	mm	U4697
2.875	3.250	0.250	inch	U6424
2.875	3.500	0.500	inch	U6423
75	85	6	mm	U4979
75	85	8	mm	U4008
75	85	10	mm	U6807
75	90	9	mm	U7363
75	90	11.4	mm	U3807
75	90	12	mm	U2133
75	100	18	mm	U6934
76.2	88.9	6.35	mm	U4698
76.2	88.9	9.52	mm	U4699
79.37	88.9	9.52	mm	U4700
3.125	3.500	0.375	inch	U6422
79.5	89	7	mm	U3806
80	90	6	mm	U7357
80	90	10	mm	U6809
80	90	13	mm	U6810
80	95	9	mm	U7330



NAK 標準型式

# UOP

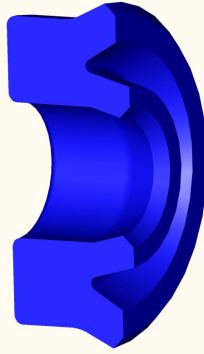
 應用環境：活塞(PISTON)  
 材質：聚氨酯(PU)

尺寸			單位	圖號
軸徑	孔徑	高度		
80	95	12	mm	U6811
80	100	10	mm	U2414
80	100	12	mm	U2388
80	100	13.5	mm	U2360
80	100	15	mm	U2404
80	101.6	12	mm	U6816
82.55	95.25	9.52	mm	U4701
3.250	3.750	0.375	inch	U6421
82.55	101.60	9.52	mm	U4637
82.55	101.60	12.70	mm	U4638
82.55	101.60	15.87	mm	U4639
85	95	7	mm	U7271
85	95	7.5	mm	U7118
85	100	9	mm	U7356
85	100	11.4	mm	U4009
85	100	12	mm	U2028
85	110	15	mm	U3298
85	110	18	mm	U5053
85.72	101.6	12.7	mm	U4702
3.375	4.000	0.500	inch	U6419
86	100	12	mm	U6817
88.9	101.6	6.35	mm	U4703
3.500	4.000	0.250	inch	U6420
3.500	4.000	0.312	inch	U6440
88.9	101.6	7.93	mm	U4704
88.9	101.6	9.52	mm	U4705
90	100	7	mm	U6820
90	100	10.5	mm	U6836
90	100	14	mm	U7885
90	105	12	mm	U1948
90	110	12	mm	U2137
90	110	15	mm	U2154
90	115	15	mm	U3005
92.07	101.6	9.52	mm	U4706
3.625	4.000	0.375	inch	U6441
95	110	10	mm	U2155

尺寸			單位	圖號
軸徑	孔徑	高度		
95	110	12	mm	U4997
95	115	14.5	mm	U6651
95	115	15	mm	U3006
95	120	15	mm	U6963
95	125	18	mm	U2335
95.25	107.95	9.52	mm	U4707
3.750	4.250	0.375	inch	U6442
95.25	114.30	15.87	mm	U4630
98	115	14.5	mm	U3873
98	150	14.5	mm	U6621
100	110	7	mm	U6799
100	110	10.5	mm	U5802
100	110	13.5	mm	U6800
100	115	10.5	mm	U6815
100	120	12	mm	U2031
100	125	15	mm	U2853
101.6	114.3	9.52	mm	U4708
4.000	4.500	0.375	inch	U6443
105	115	13.5	mm	U6814
105	120	12	mm	U1630
105	125	12	mm	U4007
105	125	15	mm	U2152
106	120	8.5	mm	U7355
107.95	127.00	9.52	mm	U4631
107.95	127.00	12.70	mm	U4632
107.95	127.00	15.87	mm	U4633
4.250	5.000	0.625	inch	U6444
110	125	9.6	mm	U2405
110	125	10	mm	U6823
110	130	12	mm	U2406
110	130	15	mm	U3652
114.3	127	6.35	mm	U4691
4.500	5.000	0.250	inch	U6445
114.3	127	9.52	mm	U4692
4.500	5.000	0.562	inch	U6446
114.3	127	14.28	mm	U4693

E2

NAK 標準型式

# UOP

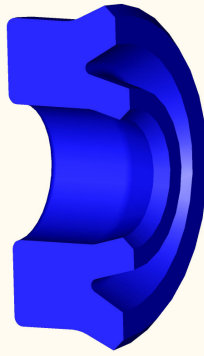
 應用環境：活塞(PISTON)  
 材質：聚氨酯(PU)

E2

尺寸			單位	圖號
軸徑	孔徑	高度		
114.3	133.35	12.7	mm	U4661
115	125	7	mm	U2115
115	125	15	mm	U2897
115	130	9	mm	U7354
115	145	18	mm	U3801
120	130	13.5	mm	U6538
120	140	12	mm	U3425
120	140	15	mm	U5740
120	150	18	mm	U2989
120.65	139.7	15.87	mm	U4666
125	140	9	mm	U6309
125	140	15	mm	U2872
125	150	13.5	mm	U6308
130	150	15	mm	U2176
130	160	18	mm	U3870
133.35	152.4	9.52	mm	U4665
5.250	6.000	0.375	inch	U6447
133.35	152.4	12.7	mm	U4664
133.35	152.4	15.87	mm	U4663
135	150	9	mm	U7351
135	160	18.5	mm	U2203
139.7	152.4	6.35	mm	U4710
139.7	152.4	9.52	mm	U4711
5.500	6.000	0.375	inch	U6448
5.500	6.000	0.562	inch	U6449
139.7	152.4	14.28	mm	U4712
140	150	7	mm	U6307
140	155	9	mm	U7802
140	160	13.5	mm	U6643
140	160	15	mm	U2828
140	165	19	mm	U7638
145	160	9	mm	U6317
145	170	19	mm	U6316
5.750	6.250	0.562	inch	U6455
146.05	158.75	14.28	mm	U4713
150	170	12	mm	U1628

尺寸			單位	圖號
軸徑	孔徑	高度		
150	170	15	mm	U2832
150	180	18	mm	U2827
158.75	177.8	9.52	mm	U4659
6.250	7.000	0.375	inch	U6456
158.75	177.8	12.7	mm	U4658
158.75	177.80	15.87	mm	U4634
6.250	7.000	0.625	inch	U6457
160	180	13.5	mm	U6325
160	180	15	mm	U1879
165	180	9	mm	U7165
165	190	16	mm	U3916
165.1	177.8	6.35	mm	U4717
6.500	7.000	0.250	inch	U6458
165.1	177.8	9.52	mm	U4718
6.500	7.000	0.375	inch	U6393
166	180	15.5	mm	U6326
170	190	15	mm	U6327
170	200	18	mm	U6366
175	190	9	mm	U4793
175	200	18.2	mm	U3643
175	200	19	mm	U5687
180	200	15	mm	U2361
180	200	18	mm	U7667
184.15	203.20	15.87	mm	U4660
190	210	12	mm	U7096
190	220	18	mm	U1988
190.5	203.2	6.35	mm	U4719
7.500	8.000	0.250	inch	U6394
195	220	16	mm	U6558
200	220	15	mm	U1756
203.2	228.6	19.05	mm	U4720
8.000	9.000	0.750	inch	U6184
220	240	16	mm	U7815
220	250	18	mm	U3863
225	250	18.2	mm	U4642
230	250	15	mm	U1757

NAK 標準型式

# COP

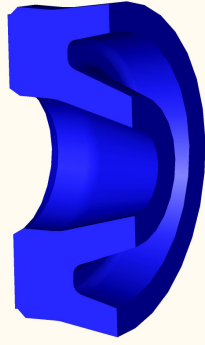

 應用環境：活塞(PISTON)  
 材質：聚氨酯(PU)

尺寸			單位	圖號
軸徑	孔徑	高度		
49.29	58.83	5.33/5.74	mm	U0284
50	58	5/7	mm	U0050
59.56	69.26	5.33/5.74	mm	U0070
69.57	79.37	5.33/5.74	mm	U0072
79.52	89.36	5.33	mm	U0228
89.60	99.57	5.33/5.74	mm	U0073
99.60	109.55	5.33/5.74	mm	U0071
104.69	114.55	5.18/5.74	mm	U0498
108.36	123.8	7.24	mm	U0550

尺寸			單位	圖號
軸徑	孔徑	高度		

NAK 標準型式

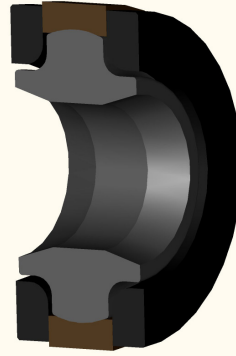
# HOD



應用環境：活塞(PISTON)  
 材質：聚四氟乙烯(PTFE)  
 丁腈橡膠(NBR)  
 尼龍(PA)

E2

尺寸			單位	圖號
軸徑	孔徑	高度		
36	50	8.5	mm	U6767
55	70	10.5	mm	U6768
75	90	10.5	mm	U6769
85	100	12	mm	U6681
105	120	12	mm	U6682
107	130	15.5	mm	U5707
112	135	15.5	mm	U5708
127	150	15.5	mm	U6683
162	185	15.5	mm	U6684
207	230	15.5	mm	U6770

尺寸			單位	圖號
軸徑	孔徑	高度		

NAK 標準型式

# HPO



應用環境：活塞(PISTON)  
 材質：聚四氟乙烯(PTFE)  
 丁腈橡膠(NBR)  
 氟素橡膠(FKM)

尺寸			單位	圖號
軸徑	孔徑	高度		
86	100	6.3	mm	U6778
51.5	60	3.8	mm	U6775
136	150	6.3	mm	U6780

尺寸			單位	圖號
軸徑	孔徑	高度		

E2





NAK 標準型式

# UOR

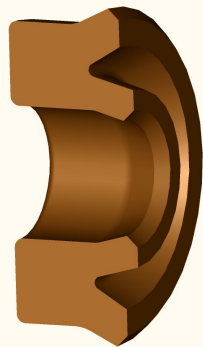

應用環境：活塞(PISTON)  
 材質：丁腈橡膠(NBR)  
 氟素橡膠(FKM)

尺寸			單位	圖號
軸徑	孔徑	高度		
4.76	11.11	3.96	mm	U7435
5	9.5	4	mm	U7947
5	10	4	mm	U7949
5	10.5	4	mm	U7948
6	13	4	mm	U7286
10	14	2.9	mm	U5622
12	16	3.2	mm	U4921
12.7	19	3.17	mm	U7660
14	23.5	4	mm	U7731
16	20	3.2	mm	U4923
16	22	4	mm	U0813
18	26	4.5	mm	U7212
18	27.4	5.2	mm	U1137
19.05	29	6.35	mm	U7436
20	30	7	mm	RD065
20.5	30	6.35	mm	U8120
21	25	3.2	mm	U4922
22	28	3.25	mm	U5733
22	35	6.35	mm	U8232
23.8	36.5	7.92	mm	U7437
1.000	1.500	0.313	inch	U7510
27.3	40	6.35	mm	U7619
28	34.3	4.8	mm	U8276
28.57	44.45	9.52	mm	U7607
30	38	6.35	mm	U7439
30	40	6/7	mm	U8301
1.188	1.500	0.156	inch	U1407
31.5	38.5	5.5	mm	U7043
37	44	5.5/5	mm	U8286
37.5	43	3.8	mm	U1634
40	50	7	mm	U7440
41.27	57.15	6.35	mm	U7438
41.3	54	9.52	mm	U7441
44.3	57	6.35	mm	U7442
45	55	7	mm	U7608
45	55	5.5/7	mm	U8300

尺寸			單位	圖號
軸徑	孔徑	高度		
50	60	4.25	mm	U5032
53	63	7	mm	U8247
54.1	70	7.93	mm	U7662
55	65	7	mm	U7429
58	70	8.5	mm	U7661
65	75	7.5	mm	U7022
67.3	80	6.35	mm	U7430
68	80	8.5	mm	U7431
73	85	8.5	mm	U7609
73	86	9.5	mm	U8146
76	95	7.4	mm	U7428
76.1	92	9.5	mm	U7611
78	90	8.5	mm	U7610
86.3	99	9.52	mm	U7009
87	99	8.5	mm	U4970
88	100	8.5	mm	U7010
89	102	12.5	mm	U7612
98	110	8.5	mm	U8083
110	125	10	mm	U7613
120.6	146	15.9	mm	U7629
124	137	9.5	mm	U8291
127.6	153	15.9	mm	U7422
133.6	159	15.9	mm	U7423
159.3	191	19	mm	U7614
160	177	11	mm	U8290
165	184	11.11	mm	U7421
165	190	21	mm	U5231

E2

















NAK 標準型式

# UNP

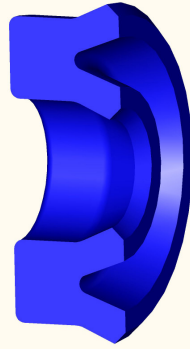
 應用環境：活塞桿(ROD)與活塞  
(PISTON)

材質：聚氨酯(PU)

尺寸			單位	圖號
軸徑	孔徑	高度		
3	9	4.5	mm	U0946
3	10	5	mm	U0487
4	10	4	mm	U2711
4	10	4.5	mm	U2444
4	12	5.5	mm	U8308
4.5	11	5	mm	U3029
4.5	12.5	4.5	mm	U0994
5	10	5	mm	U3829
5	11	5	mm	U6276
5	11	7	mm	U6275
5	12	5	mm	U0458
5	12	6	mm	U2948
5	12	6.2	mm	U6263
5	12.7	8.5	mm	U6323
5	17	9	mm	U6011
6	10	4.2	mm	U1927
6	11	7	mm	U7413
6	12	3.5	mm	U6311
6	12	4	mm	U2882
6	12	4.5	mm	U0925
6	12	5	mm	U4398
6	12	5.5	mm	U2394
6	12	6	mm	U2159
6	12	7	mm	U6312
6	12	8	mm	U0273
6	12.7	6	mm	U6244
6	13	8	mm	U3995
6	15	4	mm	U3477
6	15	5	mm	U6254
6	15	6	mm	U1779
6	15	8	mm	U2419
6	16	6	mm	U2650
6	16	6	mm	U6255
6.3	16.3	8	mm	U2301
7	14	3.2	mm	U6253
7	15	5	mm	U6261

尺寸			單位	圖號
軸徑	孔徑	高度		
7	15	7	mm	U2206
7.93	15.87	6.35	mm	U4996
8	14	4	mm	U2207
8	14	6	mm	U2613
8	15	5.7	mm	U2420
8	15	6	mm	U4582
8	15	8	mm	U2241
8	16	5.5	mm	U0277
8	16	5.7	mm	U2097
8	16	6	mm	U2976
8	16	8	mm	U3271
8	18	6	mm	U4840
8	18	8	mm	U6260
8	18	9	mm	U2557
8	22	8	mm	U0892
9	15	8	mm	U2249
9	17	6	mm	U5645
9	19	6	mm	U3038
9	19	6.5	mm	U6259
9.95	22.22	6.85	mm	U4784
10	16	4	mm	U2098
10	16	4.8	mm	U2922
10	16	5	mm	U6258
10	16	6	mm	U2210
10	18	4	mm	U4084
10	18	5	mm	U2237
10	18	5.5	mm	U3554
10	18	6	mm	U0249
10	18	8	mm	U2816
10	18	10	mm	U0698
10	20	6	mm	U3421
10	20	8	mm	U2703
10	20	10	mm	U3673
10	22	5	mm	U3672
10	22	6	mm	U4271
10	22	8	mm	U2051

E3

NAK 標準型式

# UNP

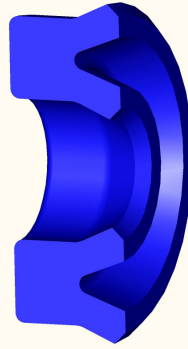
 應用環境：活塞桿(ROD)與活塞  
(PISTON)

材質：聚氨酯(PU)

E3

尺寸			單位	圖號
軸徑	孔徑	高度		
10	25	10	mm	U6257
11	17	4	mm	U6256
11	20.5	6	mm	U6228
11	20.5	6.5	mm	U6264
11.2	21.2	8	mm	U2914
12	18	4	mm	U3828
12	18	5	mm	U6319
12	18	6	mm	U4261
12	18	8	mm	U7663
12	20	5	mm	U3865
12	20	5.5	mm	U5270
12	20	7	mm	U3337
12	20	8	mm	U3056
12	22	5	mm	U2632
12	22	7	mm	U3785
12	22	8	mm	U2117
12	24	6	mm	U2186
12	24	8	mm	U2846
12	24	9	mm	U2951
12	24	10	mm	U6268
12	25	8	mm	U2289
12	25	10	mm	U2633
12	28	6	mm	U5525
12.7	19.05	3.96	mm	U5093
0.500	0.750	0.250	inch	U6438
12.70	22.22	5.25	mm	U4783
12.70	25.40	6.35	mm	U4902
0.500	1.000	0.250	inch	U6413
14	20	4	mm	U3347
14	20	4.8	mm	U2052
14	20	5	mm	U0279
14	20	6	mm	U6266
14	20	8	mm	U4127
14	22	4	mm	U6615
14	22	4.5	mm	U3990
14	22	5	mm	U4020

尺寸			單位	圖號
軸徑	孔徑	高度		
14	22	6	mm	U3641
14	22	8	mm	U3155
14	22	11	mm	U2908
14	24	8	mm	U3354
14	26	8	mm	U2198
14	28	10	mm	U6346
14	30	5	mm	U3671
15	22	4	mm	U4640
15	22	7	mm	U2171
15	25	5	mm	U2172
15	25	6	mm	U0648
15	25	8	mm	U2166
15	25	10	mm	U3922
15	27	6	mm	U3670
15	27	7	mm	U4577
15	28	8	mm	U6265
15	28	10	mm	U2984
15	30	6	mm	U6328
15	30	8	mm	U3058
15	35	10	mm	U7631
15.87	25.40	7.14	mm	U4894
15.87	28.57	6.35	mm	U4901
16	20	4.5	mm	U4085
16	22	4	mm	U2118
16	22	5	mm	U2809
16	22	7	mm	U3669
16	24	5	mm	U2248
16	24	5.7	mm	U4262
16	24	6	mm	U7621
16	24	9	mm	U3205
16	26	5	mm	U3410
16	26	6	mm	U6340
16	26	7	mm	U1780
16	26	8	mm	U2372
16	26	10	mm	U1147
16	28	6	mm	U2773



NAK 標準型式

# UNP

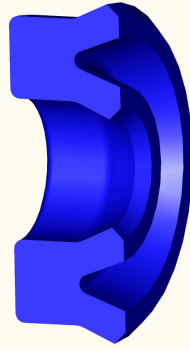
 應用環境：活塞桿(ROD)與活塞  
(PISTON)

材質：聚氨酯(PU)

尺寸			單位	圖號
軸徑	孔徑	高度		
16	32	8	mm	U3296
17	25	10	mm	U2956
17	27	8	mm	U7325
17	32	10	mm	U6343
18	25	5	mm	U2881
18	25	6	mm	U2482
18	26	5	mm	U3293
18	26	5.5	mm	U2389
18	26	6	mm	U7448
18	26	6.5	mm	U2906
18	26	8	mm	U2712
18	26	8.5	mm	U4550
18	28	8	mm	U3039
18	30	8	mm	U2556
18	30	10	mm	U6342
18	32	7	mm	U6341
18	34	8	mm	U2626
18	35	8	mm	U3624
19	25	6	mm	U2053
19	25	7	mm	U4595
0.750	1.250	0.250	inch	U6437
20	26	4	mm	U2358
20	27	6	mm	U5526
20	28	4	mm	U2223
20	28	5	mm	U3154
20	28	6	mm	U6812
20	28	7	mm	U1698
20	28	8	mm	U2516
20	29	5	mm	U6318
20	30	6	mm	U3549
20	30	8	mm	U2224
20	30	10	mm	U3288
20	32	5	mm	U6368
20	32	6	mm	U6664
20	32	7.5	mm	U4413
20	32	8	mm	U2382

尺寸			單位	圖號
軸徑	孔徑	高度		
20	33	10	mm	U5876
20	35	8	mm	U0247
20	35	10	mm	U2484
20	35	12	mm	U3292
20	36	8	mm	U6367
20	36	12	mm	U5635
20	39	10.5	mm	U6378
20	40	10	mm	U2555
20	40	12	mm	U3476
21	29.5	5	mm	U6803
21	37	12	mm	U2789
22	28	4	mm	U2485
22	28	6	mm	U6541
22	28	8	mm	U2347
22	30	4	mm	U2225
22	30	5	mm	U4147
22	30	6	mm	U2486
22	30	7	mm	U2873
22	30	8	mm	U6616
22	30	10	mm	U1908
22	32	5	mm	U2300
22	32	6	mm	U5269
22	32	8	mm	U2120
22	32	10	mm	U2798
22	34	6	mm	U7074
22	34	7	mm	U4621
22	35	10	mm	U2925
22	40	10	mm	U2971
22	40	12	mm	U3344
22.4	30	5	mm	U2774
22.4	32.4	8	mm	U4768
23	30	6.5	mm	U4908
23.5	31.5	5	mm	U4263
24	32	4	mm	U6345
24	32	5	mm	U3660
24	32	7	mm	U2868

E3

NAK 標準型式

# UNP

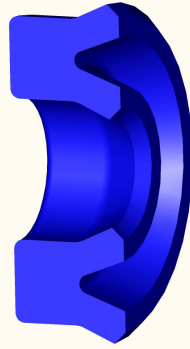
 應用環境：活塞桿(ROD)與活塞  
(PISTON)

材質：聚氨酯(PU)

E3

尺寸			單位	圖號
軸徑	孔徑	高度		
24	32	7.5	mm	U6344
24	32	8	mm	U4842
24	34	7	mm	U7664
24	36	7	mm	U7148
24	40	8	mm	U3831
24	50	12	mm	U1522
25	32	4	mm	U5688
25	32	6	mm	U8295
25	33	4	mm	U2080
25	33	5	mm	U3000
25	33	6	mm	U5792
25	33	7	mm	U3816
25	33	7.2	mm	U3312
25	33	8	mm	U3475
25	35	5	mm	U2679
25	35	6	mm	U3599
25	35	7	mm	U2810
25	35	8	mm	U2161
25	35	8.6	mm	U8263
25	35	10	mm	U2082
25	37	6	mm	U7635
25	37	7	mm	U6372
25	37	9	mm	U4960
25	38	7	mm	U7172
25	38	8	mm	U1781
25	38	9.5	mm	U2457
25	38	10	mm	U2162
25	40	8	mm	U4843
25	40	10	mm	U2432
25	45	10	mm	U2487
25	50	12	mm	U7394
25.4	31.75	4.76	mm	U4994
25.4	34.92	7.93	mm	U4683
25.4	38.1	6.35	mm	U4900
26	38	6	mm	U6680
26	38	8	mm	U2083

尺寸			單位	圖號
軸徑	孔徑	高度		
26	47	12	mm	U7703
27	35	4	mm	U5727
27	35	5	mm	U2488
27	36	6	mm	U3040
27	38	6	mm	U6370
27	43	10	mm	U1204
28	35	5	mm	U2299
28	35.5	5	mm	U2308
28	36	4	mm	U2354
28	36	5	mm	U3338
28	36	6.5	mm	U2390
28	38	6	mm	U6687
28	38	8	mm	U2290
28	38	10	mm	U2887
28	40	8	mm	U2173
28	40	10	mm	U0220
28	43	10	mm	U6377
28	44	8	mm	U3506
28	48	12	mm	U4959
28.57	38.1	7.93	mm	U7646
28.57	41.27	9.52	mm	U4899
30	36	4	mm	U8282
30	37	5.8	mm	U2704
30	37	6	mm	U3989
30	38	4	mm	U6376
30	38	5	mm	U2458
30	38	6	mm	U2247
30	38	7	mm	U2817
30	38	8	mm	U5523
30	40	5	mm	U2123
30	40	5.5	mm	U3987
30	40	6	mm	U2174
30	40	6.5	mm	U2075
30	40	7	mm	U2697
30	40	8	mm	U4016
30	40	10	mm	U2124

NAK 標準型式

# UNP

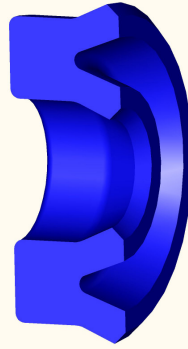
 應用環境：活塞桿(ROD)與活塞  
(PISTON)

材質：聚氨酯(PU)

尺寸			單位	圖號
軸徑	孔徑	高度		
30	40	10.2	mm	U8264
30	42	6	mm	U5550
30	42	9	mm	U2818
30	42	10	mm	U2329
30	43	6.5	mm	U4839
30	43	8	mm	U5548
30	43	10	mm	U5547
30	45	8	mm	U2467
30	45	9	mm	U2342
30	45	10	mm	U2078
30	45	10.2	mm	U2307
30	50	10	mm	U5764
30	50	12	mm	U2295
30	55	10	mm	U8074
30.16	42.86	7.93	mm	U4897
31.5	41.5	6	mm	U3313
31.75	41.27	7.93	mm	U4893
31.75	44.45	6.35	mm	U4898
31.75	44.45	9.52	mm	U4687
32	40	4	mm	U2216
32	40	5	mm	U2926
32	40	5.5	mm	U2977
32	40	6	mm	U2680
32	40	7	mm	U2870
32	40	8	mm	U2705
32	40	10	mm	U4576
32	42	6	mm	U3548
32	42	7	mm	U8130
32	42	8	mm	U5549
32	42	10	mm	U2217
32	44	4	mm	U0686
32	45	10	mm	U2292
32	47	10	mm	U2706
32	48	10	mm	U7261
32	50	10	mm	U2522
32	50	12	mm	U2819

尺寸			單位	圖號
軸徑	孔徑	高度		
33	43	10	mm	U4004
34	45	7	mm	U6374
34	45	9	mm	U2957
34	46	8	mm	U7487
34	50	14	mm	U5909
34.92	44.45	9.52	mm	U4777
34.92	50.8	9.52	mm	U7110
34.92	50.80	12.70	mm	U4887
35	42	8	mm	U8174
35	43	5.7	mm	U3314
35	43	6	mm	U3153
35	43	7	mm	U3057
35	45	6	mm	U2169
35	45	7	mm	U8281
35	45	8	mm	U2375
35	45	10	mm	U2109
35	47	6.2	mm	U6725
35	47	10	mm	U3938
35	48	10	mm	U2927
35	50	8	mm	U2446
35	50	10	mm	U2047
35	55	10	mm	U2330
35	55	12	mm	U2824
35.5	43.5	8	mm	U2713
35.5	45	6	mm	U3997
35.5	45.5	6	mm	U1265
36	44	4	mm	U2048
36	44	5.7	mm	U2110
36	44	6	mm	U6086
36	45	10	mm	U5775
36	46	7	mm	U2608
36	46	10	mm	U2359
36	50	8	mm	U5932
36	70	10	mm	U5283
38	45	6	mm	U2871
38	45	8	mm	U2963

E3

NAK 標準型式

# UNP

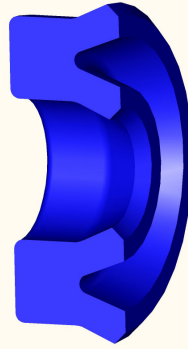
 應用環境：活塞桿(ROD)與活塞  
(PISTON)

材質：聚氨酯(PU)

E3

尺寸			單位	圖號
軸徑	孔徑	高度		
38	46	6.5	mm	U4086
38	48	6	mm	U3315
38	48	8	mm	U6717
38	48	10	mm	U2491
38	50	6	mm	U4584
38	50	8	mm	U6661
38	50	9	mm	U2043
38	50	10	mm	U2610
38	55	10	mm	U2218
38	58	10	mm	U3041
38.10	47.62	7.93	mm	U4684
38.1	50.8	9.52	mm	U7447
38.10	57.15	11.91	mm	U4891
39	47	6	mm	U2492
40	48	6	mm	U7590
40	48	8	mm	U2112
40	48	11	mm	U2192
40	50	5	mm	U2219
40	50	6	mm	U2954
40	50	6.5	mm	U2045
40	50	7	mm	U2799
40	50	8	mm	U2046
40	50	10	mm	U2099
40	50	10.2	mm	U7100
40	52	8	mm	U7260
40	55	8	mm	U6612
40	55	10	mm	U2035
40	56	8	mm	U5933
40	56	10	mm	U3098
40	56	12	mm	U7060
40	60	8	mm	U5546
40	60	10	mm	U2800
40	60	12	mm	U3860
40	60	13	mm	U2643
40	60	18	mm	U3026
40	62	15.2	mm	U4087

尺寸			單位	圖號
軸徑	孔徑	高度		
40	65	10	mm	U5934
40	65	12	mm	U3059
40	70	15	mm	U5935
40	75	10.5	mm	U5936
41	51	7	mm	U7485
41.27	57.15	11.11	mm	U4896
41.27	60.32	9.52	mm	U4892
42	50	7	mm	
42	50	8	mm	U2380
42	52	6	mm	U6373
42	52	9	mm	U5937
42	52	10	mm	U2002
42	55	10	mm	U8080
42	62	10	mm	U7671
42	62	12	mm	U3653
44	50	8.5	mm	U3661
44.45	53.97	9.52	mm	U4844
44.45	57.15	9.52	mm	U4688
44.45	60.32	11.11	mm	U4885
45	53	5.7	mm	U2776
45	53	6	mm	U7175
45	53	8	mm	U3570
45	53	10	mm	U3316
45	53	12	mm	U0566
45	53	5.7/6.3	mm	U2847
45	55	5	mm	U2036
45	55	6	mm	U3625
45	55	6.5	mm	U2037
45	55	7	mm	U5305
45	55	7.2	mm	U6613
45	55	8	mm	U5521
45	55	10	mm	U2331
45	56	7	mm	U2860
45	57	6	mm	U6689
45	57.7	9.5	mm	U2447
45	58	10	mm	U7588

NAK 標準型式

# UNP

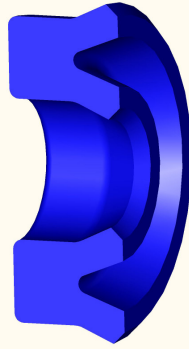
 應用環境：活塞桿(ROD)與活塞  
(PISTON)

材質：聚氨酯(PU)

尺寸			單位	圖號
軸徑	孔徑	高度		
45	60	10	mm	U2220
45	62	10	mm	U7656
45	63	10	mm	U3045
45	63	12	mm	U3663
45	65	6.5	mm	U1644
45	65	10	mm	U2438
45	65	12	mm	U3100
45	70	12	mm	U6082
45	70	15.5	mm	U7592
45	75	15	mm	U5002
46	58	12	mm	U2472
47	55	6	mm	U7632
47	57	9	mm	U7683
47	65	12	mm	U5728
47.62	63.50	7.93	mm	U4886
47.62	73.02	16.37	mm	U4779
48	58	10	mm	U3046
48	60	9	mm	U5938
48	63	10	mm	U2103
48	65	10	mm	U7737
48	68	10	mm	U1710
50	57	10	mm	U4586
50	58	7.8	mm	
50	58	8	mm	U2213
50	60	5	mm	U2164
50	60	6	mm	U2306
50	60	7.2	mm	U2371
50	60	8	mm	U4155
50	60	10	mm	U2865
50	60	11	mm	U2888
50	60	12	mm	U2187
50	60	13	mm	U2188
50	62	9	mm	U2104
50	62	12	mm	U1885
50	63	6	mm	U2869
50	63	6.5	mm	U3070

尺寸			單位	圖號
軸徑	孔徑	高度		
50	63	8	mm	U3473
50	63	9	mm	U5907
50	63	10	mm	U2332
50	63	12	mm	U7382
50	65	10	mm	U2023
50	65	12	mm	U3345
50	68	10	mm	U2473
50	70	10	mm	U2087
50	70	12	mm	U2022
50	70	18	mm	U2293
50	75	12	mm	U3864
50.8	60.32	4.76	mm	U5729
50.8	60.32	6.35	mm	U4685
50.8	60.32	7.93	mm	U4682
50.8	60.32	9.52	mm	U4686
50.8	63.5	7.93	mm	U5008
50.8	63.5	9.52	mm	U4689
50.8	66.67	9.52	mm	U6634
50.80	66.67	14.28	mm	U4907
50.8	69.85	9.52	mm	U6633
51	66	14	mm	U3862
51	76	14	mm	U3648
52	62	12	mm	U3317
52	72	10	mm	U8079
53	63	5	mm	U2221
53	63	6	mm	U3664
53	63	6.5	mm	U2351
53	65	6	mm	U8256
53	65	9	mm	U8249
54	70	12	mm	U2474
54	72	10	mm	U7259
2.126	2.520	0.268	inch	U4088
55	60	10	mm	U3662
55	63	8	mm	U8292
55	65	5	mm	U2024
55	65	6	mm	U4000

E3



NAK 標準型式

# UNP

 應用環境：活塞桿(ROD)與活塞  
(PISTON)

材質：聚氨酯(PU)

E3

尺寸			單位	圖號
軸徑	孔徑	高度		
55	65	8	mm	U6716
55	65	10	mm	U2645
55	65	11	mm	U5804
55	65	12	mm	U2991
55	70	7.5	mm	U7756
55	70	10	mm	U2305
55	70	12	mm	U2260
55	75	10	mm	U2554
55	75	12	mm	U2523
55	80	12	mm	U2634
55	80	18	mm	U1649
56	66	6	mm	U3318
56	66	6.5	mm	U2475
56	66	8	mm	U5886
56	66	10	mm	U7492
56	66	6.7/7.5	mm	U2214
56	70	12	mm	U5636
56	71	10	mm	U4117
56	76	12	mm	U3319
57	73	8	mm	U8294
57.15	69.85	9.52	mm	U4690
57.15	73.02	9.52	mm	U6637
57.15	76.20	9.52	mm	U4890
57.16	66.75	5.25	mm	U4778
60	68	8	mm	U2349
60	68	10	mm	U1523
60	68	12	mm	U5730
60	70	5	mm	U2222
60	70	6	mm	U2310
60	70	7	mm	U7412
60	70	8	mm	U3101
60	70	10	mm	U2294
60	70	12	mm	U2021
60	71	7	mm	U4264
60	72	11	mm	U7249
60	72	13	mm	U1105

尺寸			單位	圖號
軸徑	孔徑	高度		
60	75	8	mm	U8075
60	75	10	mm	U2288
60	75	12	mm	U2148
60	80	10	mm	U5783
60	80	12	mm	U2139
60	80	18	mm	U2261
60	85	10	mm	U2896
60	85	12	mm	U3817
60	85	12.5	mm	U5915
60	90	15	mm	U3047
60.32	73.02	9.52	mm	U4998
2.375	3.000	0.562	inch	U4144
60.45	76.2	14.28	mm	U4993
62	72	12.5	mm	U4961
62	78	12	mm	U5716
63	73	5	mm	U2178
63	73	6	mm	U3320
63	75	9	mm	U1056
63	75	10	mm	U2744
63	75	12	mm	U2151
63	78	10	mm	U2666
63	80	7	mm	U6399
63	80	9	mm	U2275
63	80	10	mm	U3300
63	80	12	mm	U2476
63	80	16	mm	U6901
63	83	12	mm	U5004
63	83	15	mm	U2972
63.50	76.20	9.52	mm	U4884
63.5	79.37	7.93	mm	U6638
63.5	82.55	12.7	mm	U6095
63.50	88.90	19.05	mm	U4877
64	80	8	mm	U3666
65	75	6	mm	U3321
65	75	8	mm	U5519
65	75	10	mm	U2130



NAK 標準型式

# UNP

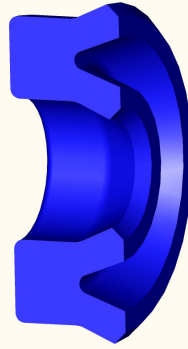
 應用環境：活塞桿(ROD)與活塞  
(PISTON)

材質：聚氨酯(PU)

尺寸			單位	圖號
軸徑	孔徑	高度		
65	75	12	mm	U2320
65	77	9	mm	U6617
65	80	10	mm	U2928
65	80	11	mm	U2411
65	80	12	mm	U2316
65	85	10	mm	U2353
65	85	12	mm	U2684
65	85	15	mm	U8065
65	90	12	mm	U2714
65	90	15	mm	U6723
65	90	18	mm	U2823
66	76	8	mm	U5914
66	77	10	mm	U6748
66	77	12	mm	U6749
66.67	79.37	10.49	mm	U4780
66.67	82.55	7.93	mm	U4906
67	77	6	mm	U3322
67	77	10	mm	U3665
67	77	12	mm	U2182
69.85	82.55	9.52	mm	U4883
69.85	85.72	9.52	mm	U4905
2.750	3.375	0.563	inch	U4444
69.85	88.90	12.70	mm	U4889
70	80	5	mm	U2844
70	80	6	mm	U2527
70	80	7	mm	U2999
70	80	8	mm	U3102
70	80	10	mm	U2262
70	80	12	mm	U2183
70	82	9	mm	U6614
70	85	8	mm	U8257
70	85	10	mm	U2477
70	85	10.5	mm	U0241
70	85	12	mm	U2180
70	90	10	mm	U2066
70	90	12	mm	U2263

尺寸			單位	圖號
軸徑	孔徑	高度		
70	90	15	mm	U6542
70	90	18	mm	U2027
70	95	12	mm	U2929
70	100	15	mm	U4962
71	80	6	mm	U3323
72	96	12	mm	U5784
73.02	85.72	9.52	mm	U4882
75	85	6	mm	U2528
75	85	8	mm	U6715
75	85	10	mm	U2243
75	85	12	mm	U2553
75	90	7.5	mm	U2068
75	90	9	mm	U2831
75	90	10	mm	U2709
75	90	12	mm	U2069
75	95	10	mm	U2795
75	95	12	mm	U2745
75	95	15	mm	U7186
75	100	12	mm	U6721
75	100	15	mm	U2413
76	91	14	mm	U3649
76.20	88.90	9.52	mm	U4881
76.2	92.07	7.93	mm	U5006
76.20	92.07	14.28	mm	U4904
3.000	3.625	0.313	inch	U4443
76.2	95.25	14.2	mm	U5518
76.20	95.25	14.28	mm	U4888
76.20	101.60	15.87	mm	U4863
78	93	10.5	mm	U5912
78	100	15	mm	U2449
80	90	5	mm	U2177
80	90	6	mm	U3994
80	90	8	mm	U3993
80	90	10	mm	U2264
80	90	12	mm	U2889
80	95	9	mm	U4267

E3

NAK 標準型式

# UNP

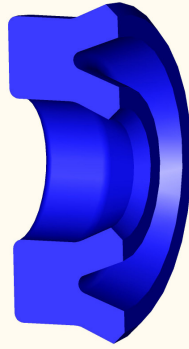

應用環境：活塞桿(ROD)與活塞  
(PISTON)

材質：聚氨酯(PU)

E3

尺寸			單位	圖號
軸徑	孔徑	高度		
80	95	10	mm	U3667
80	95	12	mm	U2334
80	100	10	mm	U2089
80	100	12	mm	U2287
80	100	15	mm	U4026
80	105	12	mm	U3346
82	92	10	mm	U1035
82.55	95.25	9.52	mm	U4880
82.55	101.60	9.52	mm	U6974
85	95	6	mm	U7306
85	95	8	mm	U7591
85	95	8.5	mm	U3062
85	95	10	mm	U6722
85	95	12	mm	U3093
85	100	8	mm	U2146
85	100	9	mm	U2145
85	100	10	mm	U6618
85	100	11	mm	U1024
85	100	12	mm	U2415
85	105	10	mm	U7666
85	105	12	mm	U2930
85	105	15	mm	U4089
85	105	18	mm	U2134
85	110	12	mm	U2344
85	115	15	mm	U6097
85.72	104.77	14.78	mm	U4775
88	96	8	mm	U4963
88.90	101.60	9.52	mm	U4879
88.90	104.77	9.52	mm	U4903
88.9	107.95	12.7	mm	U6629
88.90	114.30	9.52	mm	U4865
90	100	5	mm	U2030
90	100	7	mm	U1977
90	100	8	mm	U2746
90	100	10	mm	U3584
90	100	12	mm	U2461

尺寸			單位	圖號
軸徑	孔徑	高度		
90	102	10	mm	U7650
90	105	9	mm	U2861
90	105	12	mm	U2136
90	110	10	mm	U2618
90	110	12	mm	U2029
90	110	15	mm	U5003
90	110	18	mm	U3514
90	115	12	mm	U7647
90	115	15	mm	U2741
90	120	15	mm	U5970
92.07	117.47	12.7	mm	U4999
3.625	4.250	0.562	inch	U0196
94	115	12	mm	U5522
95	105	10	mm	U1777
95	105	11	mm	U5633
95	105	12	mm	U2416
95	110	9	mm	U4265
95	110	12	mm	U2769
95	110	15	mm	U3208
95	112	11	mm	U5928
95	112	12	mm	U2480
95	115	12	mm	U2717
95	115	18	mm	U2736
95.25	107.95	15.74	mm	U4781
96	105	11	mm	U7568
100	108	8	mm	U5517
100	110	5	mm	U2020
100	110	8	mm	U5929
100	110	11	mm	U0691
100	115	9	mm	U3939
100	115	12	mm	U2129
100	120	10	mm	U2179
100	120	12	mm	U2090
100	120	15	mm	U2742
100	120	18	mm	U2625
100	125	10	mm	U6667

NAK 標準型式

# UNP

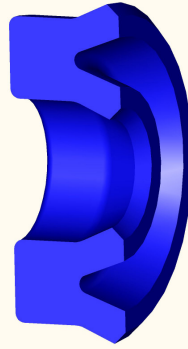
 應用環境：活塞桿(ROD)與活塞  
(PISTON)

材質：聚氨酯(PU)

尺寸			單位	圖號
軸徑	孔徑	高度		
100	125	12	mm	U2796
100	125	15	mm	U2418
100	130	12	mm	U3048
100	130	15	mm	U5931
101.6	114.3	9.52	mm	U7076
101.6	117.47	10.49	mm	U4774
4.000	4.750	0.375	inch	U6436
105	120	8	mm	U3001
105	120	10	mm	U6666
105	120	12	mm	U0405
105	120	15	mm	U2181
105	125	10	mm	U2114
105	125	12	mm	U2032
105	125	14	mm	U5282
105	125	15	mm	U2462
106	120	8.5	mm	U4598
107.95	127	12.7	mm	U5007
107.95	133.35	12.7	mm	U5001
108.36	123.82	14.28	mm	U4995
110	125	9	mm	U5579
110	125	10	mm	U6229
110	125	12	mm	U2931
110	125	15	mm	U2552
110	130	10	mm	U6668
110	130	12	mm	U2091
110	130	15	mm	U2144
110	130	18	mm	U0970
110	135	18	mm	U5930
110	140	12	mm	U6673
110	140	15	mm	U6839
112	125	9	mm	U2317
113	125	9.5	mm	U2932
4.500	5.000	0.375	inch	U6435
114.3	133.35	9.52	mm	U5005
115	125	15	mm	U5926
115	127	9	mm	U7658

尺寸			單位	圖號
軸徑	孔徑	高度		
115	130	9	mm	U7752
115	130	10	mm	U5285
115	130	12	mm	U6669
115	130	15	mm	U2127
115	135	12	mm	U3474
115	135	15	mm	U2619
115	140	12	mm	U6671
115	140	15	mm	U3049
115	140	18	mm	U7344
115	145	12	mm	U6672
115	145	15	mm	U6679
115	145	18	mm	U3822
118	133	9	mm	U6660
120	130	5	mm	U2175
120	130	14	mm	U5923
120	132	9	mm	U7649
120	135	12	mm	U6670
120	135	15	mm	U2265
120	140	10	mm	U2383
120	140	12	mm	U2092
120	140	14	mm	
120	140	15	mm	U2451
120	140	16	mm	U3909
120	145	15	mm	U7383
120	150	15	mm	U2274
123	135	9	mm	U7657
125	135	10	mm	U5632
125	137	9	mm	U7653
125	140	9	mm	U2318
125	140	10	mm	U6933
125	140	11	mm	U2125
125	140	12	mm	U3114
125	140	15	mm	U2143
125	141	18	mm	U8064
125	145	12	mm	U5658
125	145	15	mm	U2337

E3

NAK 標準型式

# UNP

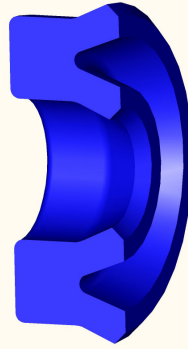
 應用環境：活塞桿(ROD)與活塞  
(PISTON)

材質：聚氨酯(PU)

E3

尺寸			單位	圖號
軸徑	孔徑	高度		
125	145	16	mm	U1278
125	145	18	mm	U6087
125	150	12	mm	U3265
125	150	15	mm	U6677
125	155	15	mm	U1790
127	142	6	mm	U5044
130	145	9	mm	U3325
130	145	12	mm	U6678
130	145	15	mm	U4964
130	150	12	mm	U6100
130	150	15	mm	U2126
130	150	16	mm	U1279
130	160	15	mm	U4990
130	160	18	mm	U6375
133.35	146.05	15.74	mm	U4782
135	150	9	mm	U5791
135	150	15	mm	U3502
135	155	15	mm	U2202
135	160	15	mm	U3050
136	150	9	mm	U3326
139.7	155.57	10.49	mm	U4773
5.500	6.250	0.375	inch	U6434
140	150	5	mm	U2170
140	150	15	mm	U0693
140	155	9	mm	U4266
140	155	15	mm	U2958
140	160	6	mm	U5634
140	160	9	mm	U7107
140	160	10	mm	U6656
140	160	12	mm	U2340
140	160	15	mm	U2826
140	160	16	mm	U1281
140	165	12	mm	U6675
140	165	15	mm	U2481
140	170	15	mm	U0578
140	170	18	mm	U6685

尺寸			單位	圖號
軸徑	孔徑	高度		
145	160	9	mm	U2863
145	165	12	mm	U6686
145	165	15	mm	U2370
146	160	9	mm	U3583
150	170	15	mm	U2339
150	170	16	mm	U1283
150	170	18	mm	U4529
150	180	15	mm	U6655
150	180	18	mm	U6909
155	170	9	mm	U8066
155	175	15	mm	U2829
155	180	15	mm	U3069
160	175	7.5	mm	U3651
160	175	8	mm	U6196
160	175	9.5	mm	U1284
160	180	9	mm	U8273
160	180	15	mm	U2341
160	185	15	mm	U4002
160	185	16	mm	U1285
160	190	15	mm	U2854
160	190	19	mm	U3543
160	200	18	mm	U8081
165	180	9	mm	U6980
165	190	15	mm	U4003
165.10	190.50	14.28	mm	U4861
170	190	15	mm	U2611
170	195	15	mm	U4988
170	200	15	mm	U6654
170	200	18	mm	U2830
170	200	18	mm	U2830
171.45	184.15	9.13	mm	U4878
175	200	15	mm	U2955
177.80	203.20	12.70	mm	U4860
180	200	12	mm	U7642
180	200	15	mm	U2338
180	200	16	mm	U5666





NAK 標準型式

# UNP1

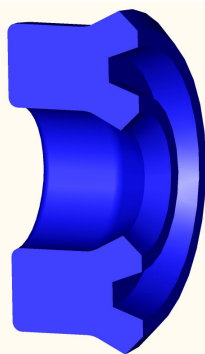
 應用環境：活塞桿(ROD)與活塞  
(PISTON)

材質：聚氨酯(PU)

E3

尺寸			單位	圖號
軸徑	孔徑	高度		
6	14	5.7	mm	U2909
8	16	5.7	mm	U2910
10	16	5	mm	U5164
10	18	5.5	mm	U2911
10	18	5.7	mm	U2912
12	18	4.5	mm	U3437
12	20	5.5	mm	U2913
12	20	5.7	mm	U5479
14	22	5.5	mm	U6108
14	22	5.7	mm	U5478
16	22	4	mm	U6122
16	24	6	mm	U2993
18	25	5.1	mm	U6012
18	26	6	mm	U4203
18	28	5.8	mm	U6379
18	28	7	mm	U6137
20	26	5	mm	U3010
20	26	5.5	mm	U6138
20	27	5.7	mm	U6139
20	28	5.8	mm	U2778
20	28	6	mm	U3562
20	28	7	mm	U7095
20	30	7.2	mm	U6005
20	30	8	mm	U6140
20	30	10	mm	U6109
21	27	4	mm	U6107
22	28	4.5	mm	U1656
22	28	5	mm	U6105
22	29	5	mm	U6104
22	30	6	mm	U1218
22	30	7	mm	U4445
22	32	7	mm	U4080
22	32	8	mm	U6103
24	30	8	mm	U1149
24	34	6	mm	U5989
25	32	4	mm	U6102

尺寸			單位	圖號
軸徑	孔徑	高度		
25	33	5.8	mm	U4991
25	33	6	mm	U3289
25	33	8	mm	U2121
25	35	5	mm	U6110
25	35	5.8	mm	U0435
25	35	7	mm	U6111
25	35	8	mm	U6112
25	35	9	mm	U6113
25	35	10	mm	U6114
25	36	5	mm	U6115
25	38	10	mm	U6116
28	36	5.8	mm	U3305
28	36	8	mm	U2084
28	38	7	mm	U6117
30	38	5.8	mm	U6124
30	38	6	mm	U5480
30	38	8	mm	U2606
30	40	7	mm	U2076
30	40	10	mm	U5962
32	40	5.8	mm	U5969
32	40	6	mm	U2541
32	40	8	mm	U2230
32	42	7	mm	U5967
32	42	8	mm	U2701
32	42	10	mm	U5966
35	43	6	mm	U2108
35	45	7	mm	U2607
35	45	10	mm	U5968
36	44	6	mm	U2049
36	44	8	mm	U2208
36	46	7	mm	U5961
36	46	10	mm	U5954
38	45	6	mm	U2543
40	48	5.8	mm	U3282
40	48	6	mm	U1655
40	48	8	mm	U2933



NAK 標準型式

# UNP1

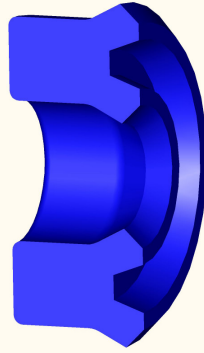
 應用環境：活塞桿(ROD)與活塞  
(PISTON)

材質：聚氨酯(PU)

尺寸			單位	圖號
軸徑	孔徑	高度		
40	50	6	mm	U5987
40	50	7	mm	U5953
40	50	10	mm	U3551
42	50	6	mm	U5947
42	52	8.5	mm	U8012
42	53	9	mm	U5946
45	53	6	mm	U5945
45	53	8	mm	U2615
45	53	10	mm	U5944
45	55	7	mm	U2702
45	55	10	mm	U5739
46	54	8	mm	U5943
50	58	8	mm	U2324
50	60	7	mm	U2039
50	60	10	mm	U3985
50	62	8	mm	U5942
50	62	10	mm	U5951
50	65	10	mm	U5952
55	63	8	mm	U2664
55	65	7.2	mm	U5940
55	65	7.5	mm	U3417
55	65	10	mm	U1219
55	65	12	mm	U5941
56	66	6.5	mm	U3935
56	66	10	mm	U5955
56	71	8.5	mm	U2544
60	68	6	mm	U3478
60	68	8	mm	U4013
60	68	13	mm	U2545
60	70	7	mm	U3015
60	70	7.2	mm	U3207
60	70	7.5	mm	U2665
60	70	10	mm	U5986
60	70	12	mm	U5985
60	72	9	mm	U0423
61	69	8	mm	U5995

尺寸			單位	圖號
軸徑	孔徑	高度		
63	71	8	mm	U1691
63	75	8.5	mm	U0418
63	75	10	mm	U5924
65	73	8	mm	U6026
65	75	12	mm	U6025
65	77	9	mm	U1553
66	80	10.5	mm	U6027
68	76	8	mm	U6028
70	78	8	mm	U6029
70	80	7	mm	U6035
70	80	10	mm	U6036
70	80	12	mm	U6037
70	82	9	mm	U3558
71	79	8	mm	U3112
72	78	6.5	mm	U6010
75	85	7.2	mm	U6038
75	85	12	mm	U6054
76	84	8	mm	U6061
78	86	13	mm	U6062
78	93	10.5	mm	U6055
79.75	85.99	6.5	mm	U2918
80	90	7.2	mm	U5939
80	90	12	mm	U6083
80	90	14	mm	U6070
85	95	7	mm	U6071
85	97	9	mm	U6069
88	96	8	mm	U6075
90	98	8	mm	U6073
90	100	6.5	mm	U6072
91	99	8	mm	U6076
95	112	11.5	mm	U6074
97	105	13	mm	U6085
100	108	8	mm	U3805
100	108	11.5	mm	U7633
107	115	8	mm	U6077
110	130	14.5	mm	U8057

E3





NAK 標準型式

# UNR

 應用環境：活塞桿(ROD)與活塞  
(PISTON)

 材質：丁腈橡膠(NBR)  
氟素橡膠(FKM)

E3

尺寸			單位	圖號
軸徑	孔徑	高度		
3.17	7.93	3.38	mm	U8119
4	12	4	mm	U8117
4.76	9.53	2.38	mm	U8118
5	12	5	mm	U1797
5.5	8.6	2.8	mm	U1684
6	12	4	mm	U1520
6	16	5	mm	U8113
6.35	11.11	3.17	mm	U7443
7.93	12.7	4.76	mm	U7444
8	13	5	mm	U5695
8	16	6	mm	U8114
8	18	5	mm	U8115
9	17	4	mm	U5068
10	15	3	mm	U5115
10	15	5	mm	U0386
10	18	6	mm	U5684
10	20	5	mm	U1696
10	25	7.5	mm	U5070
10.1	14.9	3	mm	U5114
11	17.46	4.76	mm	U7670
12	19	4	mm	U1138
12	20	4	mm	U8116
12	20	5	mm	U5916
12	22	5	mm	U6040
12	24	6	mm	U7191
13	23	5	mm	U5069
13	25	6	mm	U5071
14	22.6	5	mm	22886
14	24	5	mm	U8235
14	26	6	mm	U5072
15	25	5	mm	U7446
15	25	8	mm	U6566
15	35	10	mm	U7456
16	24	4	mm	U8231
16	24	5.5	mm	U7445
16	26	5	mm	U7622

尺寸			單位	圖號
軸徑	孔徑	高度		
16	26	7	mm	U2073
17	25	4	mm	U7461
18	24	6.2	mm	U5747
18	26	4	mm	U6041
18	26	5	mm	U0745
18	26	5.5	mm	U6962
18	28	5.3	mm	U5748
18	28	6	mm	03855
18	40	10	mm	U7628
19	25	5	mm	U7300
19	25.5	5.3	mm	U7795
19.05	31.76	6.35	mm	U7455
20	28	4	mm	U7507
20	28	5	mm	U0716
20	30	5	mm	U8055
20	30	10	mm	
20	32	5	mm	U7508
20	32	6	mm	U7514
20	40	10	mm	U7192
22	30	5	mm	U1568
22	30	6.5	mm	U6520
22	31	5	mm	U3827
22	32	5	mm	U6039
22.4	30	5	mm	U4603
23.5	31.5	5	mm	U1701
24	32	4	mm	U7462
25	33	4	mm	U8236
25	33	5	mm	U0715
25	35	5	mm	U5811
25	37	6	mm	U7457
26	38	6	mm	U7458
27	40	8	mm	U8056
28	38	5	mm	U3811
28	40	6	mm	U8237
28	40	9.5	mm	A0307
28	40	10	mm	U7278

NAK 標準型式

# UNR

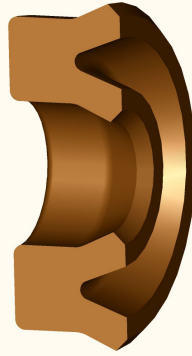
 應用環境：活塞桿(ROD)與活塞  
(PISTON)

 材質：丁腈橡膠(NBR)  
 氟素橡膠(FKM)

尺寸			單位	圖號
軸徑	孔徑	高度		
28	48	10	mm	U7530
30	40	5	mm	U7459
30	40	6	mm	U0713
30	50	10	mm	U8253
32	40	4	mm	U8246
32	40	5	mm	U7810
32	42	7	mm	U7391
32	52	10	mm	U7451
35	45	5	mm	U7460
35	45	6.1	mm	U0562
35	45	7	mm	U7246
35	47	6	mm	U8234
35.5	45	6	mm	U8125
38	50	6	mm	U7471
40	50	5	mm	U4138
40	50	6	mm	U0714
40	50	7	mm	U7450
40	52	6	mm	U8073
40	52.5	8.3	mm	U5627
40	55	11.5	mm	A0308
40	60	10	mm	U7453
44	56	6	mm	U7624
45	55	5	mm	U7452
45	55	10	mm	U1796
45	57	6	mm	U7618
46	56	5	mm	U7531
46	58	6	mm	U8252
47.63	63.50	7.43	mm	U8244
48	60	6	mm	U8245
49.21	69.85	9.52	mm	U8240
50	60	6	mm	U1389
52	62	7	mm	U7620
52	72	10	mm	U8250
53	63	5	mm	U7432
53	63	6	mm	U1390
53	65	6	mm	U7433

尺寸			單位	圖號
軸徑	孔徑	高度		
54	70	12	mm	U5073
57	68	6.5	mm	U8283
57	73.5	8	mm	U5551
60	70	6	mm	U1391
60	75	12	mm	U5074
60	80	10	mm	U5081
65	80	7.5	mm	U8241
65	85	10	mm	U4909
70	80	5	mm	U6952
70	80	6	mm	U1392
70	90	10	mm	U7497
75	95	10	mm	U7426
75	100	15	mm	U7415
80	100	10	mm	U7427
85	95	6	mm	U1393
85	100	7.5	mm	U7434
85	100	9	mm	U1895
85	100	12	mm	
85	105	12	mm	U6567
88.7	101	6.5	mm	U7284
90	100	7	mm	U7763
90	110	10	mm	U7496
90	120	15	mm	U7606
95	110	9	mm	U6640
100	125	12	mm	U7417
101.6	120.65	11.11	mm	U7735
105	125	15	mm	U7332
112	125	8.5	mm	U1394
120	150	15	mm	U7490
130	160	15	mm	U7418
133.35	158.8	12.7	mm	U7495
136	150	8.5	mm	U1395
149	160	9	mm	U7764
150	180	15	mm	U7419
155	200	35	mm	U1567
160	200	20	mm	U7420

E3







NAK 標準型式

# HB

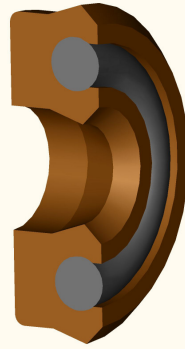
 應用環境：活塞桿(ROD)與活塞  
(PISTON)

材質：聚氨酯(PU)

丁腈橡膠(NBR)

**E3**

尺寸			單位	圖號
軸徑	孔徑	高度		
0.187	0.561	0.187	inch	U3793
0.250	0.500	0.250	inch	U6506
0.250	0.624	0.187	inch	U4757
0.277	0.527	0.187	inch	U5340
0.312	0.562	0.250	inch	U5058
0.312	0.686	0.187	inch	U4368
0.375	0.625	0.125	inch	U3499
0.375	0.625	0.250	inch	U6966
0.375	0.749	0.187	inch	U3647
0.375	0.749	0.250	inch	U3931
0.375	0.749	0.312	inch	U3370
0.437	0.687	0.125	inch	U4469
0.437	0.687	0.250	inch	U3868
0.437	0.811	0.312	inch	U4569
0.437	0.937	0.375	inch	U3903
0.500	0.750	0.125	inch	U3396
0.500	0.750	0.250	inch	U5217
0.500	0.875	0.312	inch	U6485
0.625	0.875	0.125	inch	U5655
0.625	0.875	0.250	inch	U5608
0.625	1.000	0.312	inch	U5288
0.625	1.125	0.250	inch	U7605
0.687	0.937	0.125	inch	U3968
0.687	0.937	0.250	inch	U3941
0.687	1.061	0.312	inch	U3587
0.750	1.000	0.125	inch	U4770
0.750	1.000	0.187	inch	U5152
0.750	1.000	0.250	inch	U5654
0.750	1.125	0.312	inch	U5461
0.750	1.250	0.375	inch	U6512
0.750	1.500	0.375	inch	U4512
0.812	1.062	0.125	inch	U3617
0.812	1.186	0.187	inch	U3940
0.812	1.186	0.312	inch	U3527
0.812	1.312	0.375	inch	U6502
0.812	1.436	0.500	inch	U4376

尺寸			單位	圖號
軸徑	孔徑	高度		
0.875	1.125	0.125	inch	U3634
0.875	1.125	0.250	inch	U5785
0.875	1.249	0.187	inch	U4606
0.875	1.250	0.312	inch	U6510
0.875	1.375	0.375	inch	U4192
0.937	1.187	0.125	inch	U6517
0.937	1.437	0.250	inch	U3374
1.000	1.250	0.156	inch	U5988
1.000	1.250	0.187	inch	U5023
1.000	1.250	0.250	inch	U5204
1.000	1.312	0.156	inch	U3497
1.000	1.312	0.230	inch	U4911
1.000	1.312	0.234	inch	U4161
1.000	1.374	0.250	inch	U4166
1.000	1.374	0.312	inch	U7585
1.000	1.500	0.250	inch	U6417
1.000	1.500	0.375	inch	U4912
1.000	1.624	0.312	inch	U3618
1.000	1.624	0.438	inch	U3379
1.000	1.624	0.500	inch	U4612
1.000	1.750	0.375	inch	U3487
1.062	1.374	0.312	inch	U3946
1.062	1.436	0.312	inch	U4983
1.062	1.562	0.250	inch	U5091
1.062	1.562	0.375	inch	U3951
1.125	1.375	0.250	inch	U5057
1.125	1.499	0.375	inch	U4589
1.125	1.500	0.187	inch	U5375
1.125	1.625	0.250	inch	U3612
1.125	1.625	0.312	inch	U3881
1.125	1.625	0.375	inch	U3386
1.125	1.749	0.500	inch	U3592
1.187	1.500	0.156	inch	U5621
1.187	1.561	0.187	inch	U3637
1.187	1.562	0.312	inch	U6509
1.187	1.687	0.375	inch	U3401

NAK 標準型式

# HB

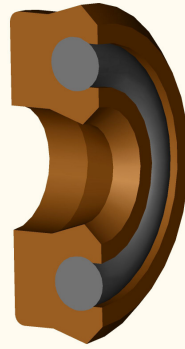
 應用環境：活塞桿(ROD)與活塞  
(PISTON)

材質：聚氨酯(PU)

丁腈橡膠(NBR)

尺寸			單位	圖號
軸徑	孔徑	高度		
1.250	1.500	0.312	inch	U4470
1.250	1.624	0.250	inch	U3501
1.250	1.624	0.312	inch	U7086
1.250	1.625	0.375	inch	U5440
1.250	1.750	0.250	inch	U5027
1.250	1.750	0.375	inch	U5292
1.250	1.874	0.312	inch	U3619
1.250	1.874	0.375	inch	U4372
1.250	1.874	0.500	inch	U3500
1.250	2.000	0.500	inch	U5601
1.250	2.000	0.625	inch	U3913
1.312	1.562	0.125	inch	U6899
1.312	1.562	0.375	inch	U3942
1.375	1.625	0.178	inch	U4868
1.375	1.625	0.250	inch	U3128
1.375	1.749	0.187	inch	U4920
1.375	1.749	0.375	inch	U4031
1.375	1.750	0.250	inch	U5808
1.375	1.750	0.312	inch	U4982
1.375	1.875	0.250	inch	U3365
1.375	1.875	0.375	inch	U5171
1.375	1.999	0.375	inch	U3615
1.375	2.000	0.312	inch	U6163
1.375	2.000	0.500	inch	U6461
1.375	2.125	0.375	inch	U3591
35	45	7	mm	U3432
1.417	1.732	0.312	inch	U5141
1.437	1.687	0.250	inch	U3943
1.500	1.750	0.125	inch	U5168
1.500	1.750	0.187	inch	U3934
1.500	1.750	0.250	inch	U3129
1.500	1.812	0.312	inch	U7000
1.500	1.874	0.187	inch	U5139
1.500	1.874	0.266	inch	U4872
1.500	1.874	0.312	inch	U3134
1.500	1.874	0.375	inch	U4799

尺寸			單位	圖號
軸徑	孔徑	高度		
1.500	2.000	0.250	inch	U5436
1.500	2.000	0.312	inch	U5620
1.500	2.000	0.375	inch	U5409
1.500	2.000	0.500	inch	U7911
1.500	2.124	0.312	inch	U3800
1.500	2.124	0.375	inch	U3616
1.500	2.125	0.500	inch	U6388
1.500	2.250	0.375	inch	U3590
1.500	2.250	0.625	inch	U3621
1.500	2.500	0.750	inch	U5795
1.562	1.936	0.375	inch	U4871
1.625	1.875	0.125	inch	U4760
1.625	1.875	0.250	inch	U6065
1.625	1.999	0.250	inch	U3404
1.625	1.999	0.266	inch	U4758
1.625	2.000	0.187	inch	U5656
1.625	2.000	0.312	inch	U5496
1.625	2.000	0.375	inch	U5605
1.625	2.125	0.250	inch	U3596
1.625	2.125	0.375	inch	U6513
1.625	2.249	0.500	inch	U3594
1.625	2.250	0.375	inch	U7177
1.625	2.375	0.375	inch	U3597
1.687	2.061	0.312	inch	U3830
1.687	2.311	0.500	inch	U3977
1.750	2.000	0.250	inch	U6508
1.750	2.124	0.187	inch	U5059
1.750	2.124	0.250	inch	U3524
1.750	2.124	0.312	inch	U3368
1.750	2.124	0.375	inch	U3586
1.750	2.250	0.250	inch	U3613
1.750	2.250	0.500	inch	U4795
44.45	59.92	12.7	mm	U5323
1.750	2.374	0.312	inch	U3494
1.750	2.374	0.375	inch	U3387
1.750	2.375	0.500	inch	U5445

E3

NAK 標準型式

# HB

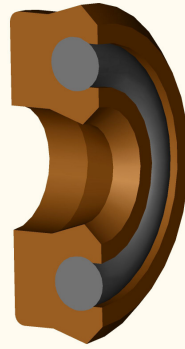
 應用環境：活塞桿(ROD)與活塞  
(PISTON)

材質：聚氨酯(PU)

丁腈橡膠(NBR)

**E3**

尺寸			單位	圖號
軸徑	孔徑	高度		
1.750	2.500	0.375	inch	U4075
1.750	2.500	0.625	inch	U5463
1.750	2.750	0.750	inch	U6483
45	55	7.3	mm	U5131
1.813	2.187	0.312	inch	U3403
1.875	2.125	0.125	inch	U4755
1.875	2.249	0.187	inch	U4167
1.875	2.249	0.266	inch	U4646
1.875	2.249	0.312	inch	U4593
1.875	2.250	0.375	inch	U6395
1.875	2.375	0.375	inch	U3598
1.875	2.499	0.375	inch	U5432
1.875	2.499	0.437	inch	U4752
1.875	2.500	0.312	inch	U5788
1.937	2.311	0.281	inch	U3969
1.937	2.437	0.375	inch	U4749
2.000	2.374	0.312	inch	U4798
2.000	2.374	0.375	inch	U5082
2.000	2.375	0.187	inch	U5169
2.000	2.375	0.275	inch	U5344
2.000	2.500	0.250	inch	U3382
2.000	2.500	0.312	inch	U5890
2.000	2.500	0.375	inch	U4200
2.000	2.624	0.375	inch	U3620
2.000	2.624	0.500	inch	U3535
2.000	2.624	0.562	inch	U3633
2.000	2.625	0.312	inch	U5677
2.000	2.750	0.437	inch	U3622
2.000	2.750	0.500	inch	U5438
2.000	3.000	0.750	inch	U6418
2.125	2.375	0.125	inch	U3944
2.125	2.375	0.250	inch	U6900
2.125	2.500	0.187	inch	U5408
2.125	2.500	0.265	inch	U5348
2.125	2.500	0.375	inch	U5574
2.125	2.625	0.250	inch	U3375

尺寸			單位	圖號
軸徑	孔徑	高度		
2.125	2.625	0.375	inch	U6503
2.125	2.875	0.375	inch	U3682
2.125	3.125	0.500	inch	U3690
2.250	2.500	0.250	inch	U3495
2.250	2.500	0.375	inch	U3945
2.250	2.624	0.187	inch	U3614
2.250	2.624	0.312	inch	U3957
2.250	2.625	0.375	inch	U5350
2.250	2.750	0.375	inch	U5609
2.250	2.875	0.312	inch	U5595
2.250	2.875	0.500	inch	U6384
2.250	3.000	0.375	inch	U3463
2.250	3.000	0.625	inch	U6472
2.250	3.124	0.625	inch	U4018
2.250	3.250	0.500	inch	U3691
2.375	2.749	0.187	inch	U3971
2.375	2.749	0.266	inch	U3972
2.375	2.749	0.500	inch	U3947
2.375	2.750	0.250	inch	U5798
2.375	2.750	0.375	inch	U5647
2.375	2.875	0.250	inch	U4490
2.375	2.875	0.375	inch	U3383
2.375	2.999	0.375	inch	U3683
2.375	2.999	0.500	inch	U3681
2.375	3.000	0.312	inch	U5607
2.375	3.125	0.375	inch	U4076
2.375	3.125	0.625	inch	U6473
2.391	2.953	0.453	inch	U5123
2.500	2.750	0.250	inch	U3593
2.500	2.874	0.187	inch	U3457
2.500	2.874	0.312	inch	U4570
2.500	2.875	0.250	inch	U5648
2.500	2.875	0.375	inch	U5346
2.500	3.000	0.250	inch	U5061
2.500	3.000	0.312	inch	U3139
2.500	3.000	0.375	inch	U5062

NAK 標準型式

# HB

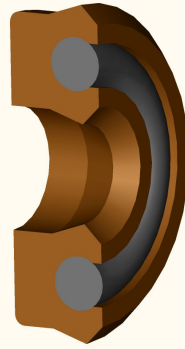
 應用環境：活塞桿(ROD)與活塞  
(PISTON)

材質：聚氨酯(PU)

丁腈橡膠(NBR)

尺寸			單位	圖號
軸徑	孔徑	高度		
2.500	3.000	0.500	inch	U4987
63.5	78.74	12.7	mm	U5324
2.500	3.125	0.312	inch	U7794
2.500	3.125	0.375	inch	U7604
2.500	3.125	0.500	inch	U6493
2.500	3.250	0.375	inch	U3364
2.500	3.250	0.500	inch	U5460
2.500	3.250	0.625	inch	U3384
2.500	3.500	0.500	inch	U3914
2.625	2.999	0.281	inch	U3397
2.625	3.000	0.187	inch	U5403
2.625	3.000	0.250	inch	U6467
2.625	3.000	0.375	inch	U6500
2.625	3.125	0.375	inch	U6514
2.625	3.249	0.312	inch	U3692
2.625	3.375	0.625	inch	U5650
2.750	3.000	0.125	inch	U3372
2.750	3.000	0.250	inch	U3392
2.750	3.124	0.281	inch	U3458
2.750	3.124	0.312	inch	U3684
2.750	3.125	0.375	inch	U6352
2.750	3.250	0.250	inch	U5657
2.750	3.250	0.375	inch	U5334
2.750	3.250	0.500	inch	U5120
2.750	3.374	0.312	inch	U3956
2.750	3.375	0.375	inch	U5596
2.750	3.375	0.500	inch	U6494
2.750	3.500	0.500	inch	U5573
2.750	3.500	0.625	inch	U6497
2.875	3.249	0.250	inch	U4588
2.875	3.249	0.281	inch	U3462
2.875	3.250	0.375	inch	U5336
2.875	3.375	0.375	inch	U4590
2.875	3.499	0.375	inch	U3448
2.875	3.500	0.500	inch	U6495
2.875	3.625	0.375	inch	U3689

尺寸			單位	圖號
軸徑	孔徑	高度		
75	90.5	6.3	mm	U7883
3.000	3.250	0.250	inch	U4645
3.000	3.250	0.375	inch	U5437
3.000	3.374	0.187	inch	U3389
3.000	3.374	0.312	inch	U3135
3.000	3.375	0.375	inch	U5455
3.000	3.500	0.250	inch	U3693
3.000	3.500	0.375	inch	U5476
3.000	3.500	0.500	inch	U5442
3.000	3.624	0.312	inch	U3685
3.000	3.624	0.500	inch	U3385
3.000	3.624	0.562	inch	U3687
3.000	3.750	0.562	inch	U4471
3.000	4.000	0.375	inch	U3915
3.000	4.000	0.500	inch	U3983
3.125	3.499	0.375	inch	U4984
3.125	3.500	0.312	inch	U6064
3.125	3.625	0.250	inch	U3722
3.125	3.625	0.375	inch	U4032
3.125	3.749	0.312	inch	U3958
3.125	3.750	0.500	inch	U6066
3.125	3.875	0.562	inch	U4629
3.250	3.500	0.139	inch	U4072
3.250	3.624	0.375	inch	U3136
3.250	3.750	0.250	inch	U3366
3.250	3.750	0.375	inch	U6492
3.250	3.750	0.500	inch	U4808
3.250	3.874	0.312	inch	U3982
3.250	3.875	0.500	inch	U6337
3.250	4.000	0.500	inch	U3141
3.250	4.000	0.562	inch	U4870
3.250	4.000	0.625	inch	U6382
3.250	4.250	0.500	inch	U4246
3.375	3.749	0.187	inch	U3449
3.375	3.749	0.250	inch	U3371
3.375	3.750	0.375	inch	U6397

E3



NAK 標準型式

# HB

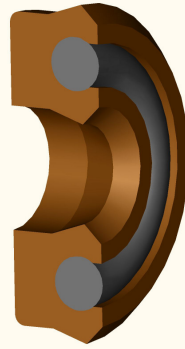
 應用環境：活塞桿(ROD)與活塞  
(PISTON)

材質：聚氨酯(PU)

丁腈橡膠(NBR)

**E3**

尺寸			單位	圖號
軸徑	孔徑	高度		
3.375	3.875	0.375	inch	U4591
3.375	3.999	0.625	inch	U3959
3.375	4.000	0.312	inch	U5511
3.375	4.000	0.500	inch	U6496
3.375	4.375	0.625	inch	U6484
3.500	3.874	0.187	inch	U3464
3.500	3.874	0.281	inch	U4759
3.500	4.000	0.250	inch	U5065
3.500	4.000	0.312	inch	U3974
3.500	4.000	0.375	inch	U3695
3.500	4.000	0.625	inch	U5790
3.500	4.250	0.500	inch	U3686
3.500	4.250	0.562	inch	U3679
3.500	4.250	0.625	inch	U6389
90	105	6.3	mm	U4544
3.625	3.999	0.250	inch	U3450
3.625	3.999	0.375	inch	U3082
3.625	4.375	0.375	inch	U3961
3.625	4.375	0.625	inch	U5434
3.750	4.250	0.250	inch	U3723
3.750	4.250	0.375	inch	U5892
3.750	4.250	0.562	inch	U4128
3.750	4.500	0.375	inch	U4242
3.750	4.500	0.625	inch	U3143
3.750	4.750	0.750	inch	U3966
3.875	4.249	0.375	inch	U3716
3.875	4.250	0.187	inch	U5799
3.875	4.375	0.375	inch	U4592
3.875	4.499	0.375	inch	U4611
4.000	4.374	0.375	inch	U4379
4.000	4.5000	0.312	inch	U5565
4.000	4.5000	0.375	inch	U5443
4.000	4.500	0.562	inch	U6392
4.000	4.625	0.562	inch	U6353
4.000	4.750	0.625	inch	U3734
4.000	4.874	0.625	inch	U3907

尺寸			單位	圖號
軸徑	孔徑	高度		
4.000	5.000	0.500	inch	U4594
4.125	4.499	0.187	inch	U3369
4.125	4.499	0.375	inch	U3137
4.125	4.625	0.562	inch	U3731
4.125	4.875	0.625	inch	U4243
4.125	4.875	0.750	inch	U3733
105	125	9.5	mm	U0769
4.250	4.624	0.281	inch	U4753
4.250	4.624	0.375	inch	U4120
4.250	4.750	0.375	inch	U6334
4.250	5.000	0.375	inch	U3962
4.250	5.000	0.562	inch	U4568
4.250	5.000	0.625	inch	U6385
4.250	5.500	0.750	inch	U5137
4.375	4.875	0.250	inch	U3775
4.375	4.875	0.375	inch	U4021
4.375	4.875	0.562	inch	U3952
4.375	4.999	0.500	inch	U3979
4.375	5.125	0.500	inch	U4511
4.437	4.999	0.500	inch	U4489
4.500	4.874	0.187	inch	U3729
4.500	4.874	0.312	inch	U4794
4.500	4.874	0.375	inch	U3948
4.500	5.000	0.250	inch	U3776
4.500	5.000	0.375	inch	U3732
4.500	5.000	0.500	inch	U4129
4.500	5.000	0.562	inch	U5338
4.500	5.124	0.625	inch	U4121
4.500	5.250	0.375	inch	U4126
4.500	5.250	0.625	inch	U6383
4.500	5.500	0.500	inch	U3453
4.625	5.125	0.250	inch	U3777
4.625	5.375	0.625	inch	U3144
4.687	5.249	0.625	inch	U4790
120	135.5	6.3	mm	U7904
4.750	5.124	0.375	inch	U4509



NAK 標準型式

# HB

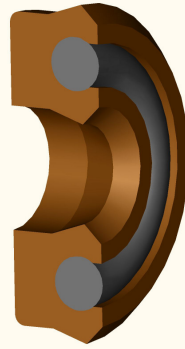
 應用環境：活塞桿(ROD)與活塞  
(PISTON)

材質：聚氨酯(PU)

丁腈橡膠(NBR)

尺寸			單位	圖號
軸徑	孔徑	高度		
4.750	5.250	0.250	inch	U3953
4.750	5.250	0.375	inch	U6336
4.750	5.250	0.500	inch	U5566
4.750	5.250	0.562	inch	U3795
4.750	5.374	0.562	inch	U3911
4.750	5.500	0.500	inch	U6480
4.750	5.500	0.625	inch	U6381
4.875	5.250	0.375	inch	U5564
4.875	5.375	0.375	inch	U4022
4.875	5.625	0.562	inch	U3963
4.875	5.625	0.625	inch	U4244
5.000	5.374	0.312	inch	U3838
5.000	5.500	0.562	inch	U3741
5.000	5.624	0.625	inch	U3912
5.000	5.750	0.500	inch	U3451
5.000	5.750	0.625	inch	U6481
5.000	5.874	0.750	inch	U3908
5.000	6.000	0.500	inch	U3454
5.000	6.000	0.750	inch	U3124
5.125	5.625	0.250	inch	U5029
5.125	5.875	0.625	inch	U4061
5.250	5.874	0.625	inch	U4071
5.250	6.000	0.500	inch	U6482
5.250	6.000	0.562	inch	U4472
5.250	6.250	0.750	inch	U3967
5.375	5.999	0.312	inch	U4037
5.375	5.999	0.562	inch	U3960
5.375	6.000	0.625	inch	U6469
5.437	5.937	0.375	inch	U3749
5.500	6.000	0.375	inch	U3910
5.500	6.000	0.500	inch	U5602
5.500	6.000	0.562	inch	U3763
5.500	6.125	0.625	inch	U7267
5.500	6.250	0.625	inch	U3764
5.500	6.500	0.500	inch	U3455
5.500	6.500	0.750	inch	U4125

尺寸			單位	圖號
軸徑	孔徑	高度		
140	155.5	6.3	mm	U7884
5.625	5.999	0.218	inch	U3949
5.625	6.000	0.375	inch	U7018
5.625	6.125	0.250	inch	U3954
5.750	6.124	0.375	inch	U4750
5.750	6.250	0.562	inch	U3748
5.750	6.500	0.375	inch	U3964
5.750	6.500	0.625	inch	U4168
5.875	6.625	0.625	inch	U4754
6.000	6.374	0.375	inch	U3753
6.000	6.500	0.250	inch	U3778
6.000	6.500	0.375	inch	U3367
6.000	6.500	0.437	inch	U3399
6.000	6.500	0.500	inch	U4077
6.000	6.500	0.562	inch	U4079
6.000	6.624	0.625	inch	U4131
6.000	6.750	0.500	inch	U3750
6.000	6.750	0.625	inch	U3796
6.000	7.000	0.750	inch	U6362
6.250	6.500	0.125	inch	U3792
6.250	6.750	0.375	inch	U3955
6.250	7.000	0.500	inch	U3071
6.250	7.000	0.625	inch	U3766
6.250	7.250	0.750	inch	U3461
6.375	6.999	0.312	inch	U3980
6.500	6.874	0.210	inch	U3950
6.500	7.000	0.250	inch	U7909
6.500	7.000	0.500	inch	U5535
6.500	7.000	0.562	inch	U6348
6.500	7.124	0.625	inch	U4132
6.500	7.250	0.500	inch	U3981
6.750	7.250	0.562	inch	U4130
6.750	7.374	0.500	inch	U5119
6.750	7.500	0.625	inch	U3758
6.875	7.625	0.625	inch	U3452
7.000	7.500	0.250	inch	U3779

E3



NAK 標準型式

# HD

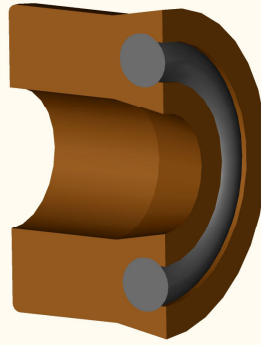
 應用環境：活塞桿(ROD)與活塞  
(PISTON)

材質：聚氨酯(PU)

丁腈橡膠(NBR)

尺寸			單位	圖號
軸徑	孔徑	高度		
0.250	0.500	0.250	inch	U6463
0.375	0.749	0.312	inch	U3498
0.375	0.875	0.375	inch	U6973
0.437	0.811	0.312	inch	U4647
0.500	0.750	0.250	inch	U5148
0.625	0.875	0.250	inch	U4571
0.625	0.999	0.312	inch	U4073
0.625	1.125	0.375	inch	U3904
0.687	0.937	0.250	inch	U4370
0.750	1.000	0.250	inch	U6908
0.750	1.125	0.312	inch	U5563
0.750	1.250	0.375	inch	U3606
0.875	1.125	0.187	inch	U6250
0.875	1.125	0.250	inch	U5226
0.875	1.249	0.312	inch	U3378
1.000	1.374	0.250	inch	U3761
1.000	1.500	0.375	inch	U3607
1.125	1.500	0.312	inch	U5766
1.125	1.625	0.375	inch	U3608
1.187	1.437	0.187	inch	U5170
1.187	1.437	0.250	inch	U5136
1.250	1.500	0.250	inch	U5370
1.250	1.624	0.312	inch	U3133
1.250	1.750	0.375	inch	U3349
1.250	1.874	0.500	inch	U4751
1.375	1.625	0.187	inch	U4613
1.375	1.749	0.312	inch	U3489
1.375	1.750	0.375	inch	U7047
1.375	1.875	0.375	inch	U3609
1.375	1.999	0.375	inch	U4807
1.500	1.750	0.250	inch	U6357
1.500	1.874	0.281	inch	U3080
1.500	1.875	0.375	inch	U6489
1.500	2.000	0.312	inch	U3610
1.500	2.000	0.375	inch	U3350
1.562	1.936	0.250	inch	U3588

尺寸			單位	圖號
軸徑	孔徑	高度		
1.625	1.875	0.25	inch	U7406
1.625	1.999	0.312	inch	U3373
1.625	2.000	0.250	inch	U5289
1.750	2.000	0.250	inch	U6390
1.750	2.250	0.500	inch	U6907
1.875	2.249	0.250	inch	U4644
1.875	2.249	0.375	inch	U4162
2.000	2.375	0.375	inch	U5619
2.000	2.500	0.375	inch	U3632
2.000	2.750	0.625	inch	U5094
2.125	2.375	0.250	inch	U5056
2.125	2.499	0.312	inch	U4060
2.125	2.499	0.375	inch	U3970
2.125	2.625	0.375	inch	U3611
2.125	2.749	0.500	inch	U3459
2.125	2.875	0.625	inch	U4374
2.250	2.624	0.375	inch	U4573
2.250	2.750	0.375	inch	U6460
2.250	2.750	0.562	inch	U3644
2.250	2.875	0.500	inch	U5779
2.250	3.000	0.625	inch	U5589
2.375	2.875	0.375	inch	U5562
2.375	2.999	0.500	inch	U3680
2.500	3.000	0.312	inch	U3699
2.500	3.000	0.375	inch	U5063
2.500	3.125	0.500	inch	U6332
2.625	3.000	0.375	inch	U6347
2.750	3.250	0.375	inch	U3698
2.750	3.500	0.625	inch	U4869
2.875	3.250	0.250	inch	U6468
3.000	3.375	0.375	inch	U6364
3.000	3.500	0.375	inch	U5362
3.000	3.500	0.562	inch	U3697
3.125	3.500	0.375	inch	U6354
3.125	3.625	0.375	inch	U3720
3.250	3.624	0.375	inch	U4985

E3



NAK 標準型式

# HS

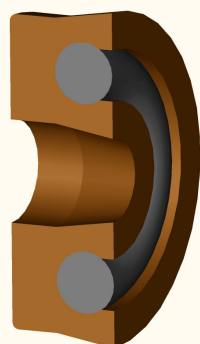
 應用環境：活塞桿(ROD)與活塞  
(PISTON)

材質：聚氨酯(PU)

丁腈橡膠(NBR)

尺寸			單位	圖號
軸徑	孔徑	高度		
0.187	0.437	0.125	inch	U3490
0.250	0.500	0.125	inch	U6499
0.250	0.624	0.187	inch	U3131
0.250	0.750	0.250	inch	U4510
0.312	0.562	0.125	inch	U5431
0.312	0.686	0.187	inch	U3526
0.312	0.748	0.218	inch	U7089
0.375	0.625	0.125	inch	U3126
0.375	0.749	0.187	inch	U3491
0.375	0.875	0.250	inch	U4190
0.437	0.687	0.125	inch	U3395
0.437	0.749	0.156	inch	U4191
0.437	0.811	0.187	inch	U3132
0.437	0.937	0.250	inch	U4371
0.500	0.750	0.125	inch	U5649
0.500	0.874	0.187	inch	U5165
0.500	1.000	0.250	inch	U3646
0.531	0.781	0.125	inch	U4369
0.562	0.812	0.125	inch	U5095
0.562	1.062	0.250	inch	U4373
0.625	0.875	0.125	inch	U5060
0.625	0.937	0.156	inch	U4986
0.625	1.000	0.187	inch	U6486
0.656	1.030	0.187	inch	U4756
0.687	1.062	0.187	inch	U6518
0.750	1.000	0.125	inch	U6507
0.750	1.062	0.156	inch	U7405
0.750	1.124	0.187	inch	U4977
0.750	1.186	0.187	inch	U3973
0.812	1.062	0.125	inch	U4609
0.812	1.436	0.312	inch	U4655
0.812	1.562	0.375	inch	U7634
0.875	1.125	0.125	inch	U5439
0.875	1.250	0.187	inch	U6487
0.875	1.375	0.250	inch	U3645
0.875	1.500	0.312	inch	U7037

尺寸			單位	圖號
軸徑	孔徑	高度		
0.875	1.660	0.375	inch	U3140
0.937	1.187	0.125	inch	U6358
0.938	1.312	0.187	inch	U3402
1.000	1.312	0.156	inch	U6965
1.000	1.374	0.187	inch	U3528
1.000	1.500	0.250	inch	U3602
1.000	1.624	0.312	inch	U5125
1.000	2.000	0.500	inch	U6580
1.062	1.436	0.187	inch	U4649
1.125	1.375	0.125	inch	U3127
1.125	1.437	0.156	inch	U7268
1.125	1.500	0.187	inch	U7049
1.125	1.625	0.250	inch	U6349
1.125	1.750	0.312	inch	U6331
1.125	1.875	0.375	inch	U4074
1.187	1.437	0.125	inch	U4656
1.187	1.500	0.156	inch	U5847
1.187	1.687	0.250	inch	U5462
1.187	1.811	0.312	inch	U5147
1.250	1.500	0.125	inch	U5121
1.250	1.562	0.156	inch	U6465
1.250	1.624	0.187	inch	U3376
1.250	1.750	0.250	inch	U5173
1.250	2.000	0.375	inch	U5618
1.312	1.687	0.187	inch	U5385
1.312	1.812	0.250	inch	U4375
1.312	1.936	0.312	inch	U3976
1.375	1.687	0.156	inch	U6466
1.375	1.750	0.187	inch	U6488
1.375	1.999	0.312	inch	U3595
1.437	1.687	0.125	inch	U4572
1.437	1.811	0.187	inch	U3492
1.437	1.937	0.250	inch	U6251
1.500	1.812	0.156	inch	U4910
1.500	1.875	0.187	inch	U5415
1.500	2.000	0.250	inch	U5138

E3



NAK 標準型式

# HS

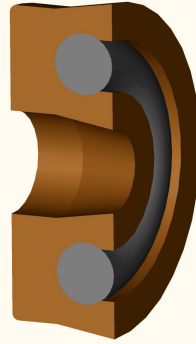
 應用環境：活塞桿(ROD)與活塞  
(PISTON)

材質：聚氨酯(PU)

丁腈橡膠(NBR)

E3

尺寸			單位	圖號
軸徑	孔徑	高度		
1.500	2.124	0.312	inch	U3585
1.500	2.250	0.375	inch	U6471
1.562	1.937	0.187	inch	U5172
1.562	2.312	0.375	inch	U4513
1.625	1.999	0.187	inch	U3589
1.625	2.125	0.250	inch	U3603
1.625	2.249	0.312	inch	U3496
1.625	2.375	0.375	inch	U6329
1.750	2.000	0.125	inch	U3130
1.750	2.124	0.187	inch	U6718
1.750	2.250	0.250	inch	U3138
1.750	2.375	0.312	inch	U6350
1.750	2.624	0.437	inch	U4245
1.875	2.125	0.125	inch	U5891
1.875	2.249	0.187	inch	U3488
1.875	2.375	0.250	inch	U3604
1.875	2.499	0.312	inch	U3400
1.875	2.625	0.375	inch	U3638
1.937	2.311	0.187	inch	U3377
2.000	2.375	0.187	inch	U6511
2.000	2.500	0.250	inch	U4806
2.000	2.625	0.312	inch	U5889
2.000	2.750	0.375	inch	U6363
2.000	3.000	0.500	inch	U6359
2.125	2.625	0.250	inch	U3605
2.125	2.749	0.312	inch	U4035
2.125	2.875	0.375	inch	U3688
2.250	2.625	0.187	inch	U6391
2.250	2.750	0.250	inch	U6491
2.250	2.875	0.312	inch	U6333
2.250	3.000	0.375	inch	U3715
2.312	2.874	0.281	inch	U3975
2.375	2.625	0.125	inch	U6464
2.375	2.875	0.250	inch	U3704
2.375	3.000	0.312	inch	U5848
2.375	3.125	0.375	inch	U3077

尺寸			單位	圖號
軸徑	孔徑	高度		
2.500	2.874	0.187	inch	U5025
2.500	2.936	0.218	inch	U3079
2.500	3.125	0.312	inch	U5571
2.500	3.250	0.375	inch	U5846
2.500	3.375	0.437	inch	U5964
2.500	3.750	0.625	inch	U5218
2.625	2.875	0.125	inch	U3694
2.625	3.125	0.250	inch	U3703
2.625	3.250	0.312	inch	U6462
2.625	3.375	0.375	inch	U3493
2.750	3.000	0.125	inch	U5652
2.750	3.000	0.125	inch	U5651
2.750	3.374	0.312	inch	U4610
2.750	3.500	0.375	inch	U4122
2.750	4.000	0.625	inch	U4030
2.812	3.248	0.218	inch	U5126
2.875	3.125	0.125	inch	U4165
2.875	3.375	0.250	inch	U6356
2.875	3.500	0.312	inch	U5600
2.875	3.625	0.375	inch	U4214
3.000	3.374	0.187	inch	U4034
3.000	3.437	0.218	inch	U5216
3.000	3.500	0.250	inch	U3456
3.000	3.624	0.312	inch	U4070
3.000	3.750	0.375	inch	U5064
3.000	4.000	0.500	inch	U6338
3.125	3.500	0.187	inch	U7750
3.125	3.625	0.250	inch	U5083
3.125	3.749	0.312	inch	U3978
3.125	3.875	0.375	inch	U4377
3.250	3.750	0.250	inch	U3702
3.250	3.875	0.312	inch	U5433
3.250	4.000	0.375	inch	U6498
3.250	4.500	0.625	inch	U5593
3.375	3.749	0.187	inch	U4163
3.375	3.875	0.250	inch	U3701



NAK 標準型式

# HS

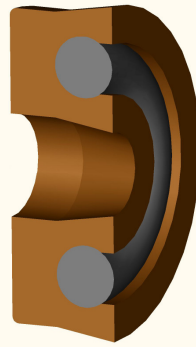
 應用環境：活塞桿(ROD)與活塞  
(PISTON)

材質：聚氨酯(PU)

丁腈橡膠(NBR)

尺寸			單位	圖號
軸徑	孔徑	高度		
3.500	3.875	0.187	inch	U6335
3.500	4.000	0.250	inch	U3718
3.500	4.125	0.312	inch	U6470
3.500	4.250	0.375	inch	U7050
3.625	4.000	0.187	inch	U5441
3.625	4.125	0.250	inch	U3700
3.625	4.375	0.375	inch	U4796
3.625	4.499	0.375	inch	U4029
3.625	4.625	0.500	inch	U5225
3.750	4.250	0.250	inch	U3719
3.750	4.750	0.500	inch	U3730
3.750	5.000	0.625	inch	U5459
3.875	4.249	0.187	inch	U4069
3.875	4.375	0.250	inch	U3740
3.875	4.499	0.312	inch	U3081
4.000	4.374	0.187	inch	U4164
4.000	4.500	0.250	inch	U6365
4.000	4.750	0.375	inch	U6360
4.000	4.874	0.437	inch	U3068
4.000	5.000	0.500	inch	U6361
4.000	5.250	0.625	inch	U5887
4.062	4.812	0.375	inch	U3906
4.125	4.499	0.187	inch	U3794
4.125	5.125	0.500	inch	U3390
4.250	5.000	0.375	inch	U3363
4.250	5.250	0.500	inch	U5592
4.312	5.312	0.500	inch	U3460
4.375	4.875	0.250	inch	U5569
4.437	4.999	0.281	inch	U4059
4.500	4.875	0.187	inch	U5572
4.500	5.000	0.250	inch	U5404
4.500	5.250	0.375	inch	U3744
4.500	5.500	0.500	inch	U6330
4.500	5.750	0.625	inch	U5965
4.625	5.125	0.250	inch	U3747
4.750	5.500	0.375	inch	U3992

尺寸			單位	圖號
軸徑	孔徑	高度		
4.750	6.000	0.625	inch	U4033
4.875	5.375	0.250	inch	U3746
5.000	5.500	0.250	inch	U5492
5.000	5.750	0.375	inch	U4036
5.250	5.750	0.250	inch	U5444
5.375	5.750	0.187	inch	U6459
5.375	5.999	0.312	inch	U4514
5.437	5.999	0.281	inch	U4488
5.437	6.437	0.500	inch	U3752
5.500	6.000	0.250	inch	U5447
5.500	6.250	0.375	inch	U5435
5.500	6.500	0.500	inch	U5410
5.625	6.375	0.375	inch	U4797
5.750	6.250	0.250	inch	U3767
5.875	6.375	0.250	inch	U5494
6.000	6.750	0.375	inch	U3362
6.250	6.750	0.250	inch	U3768
6.500	7.000	0.250	inch	U5448
6.625	7.250	0.312	inch	U5591
6.750	7.250	0.250	inch	U3755
6.765	7.515	0.375	inch	U3757
7.000	7.750	0.375	inch	U6351
7.000	8.250	0.625	inch	U6579
7.125	7.625	0.250	inch	U7014
7.250	7.750	0.250	inch	U3769
7.250	8.000	0.375	inch	U5407
7.250	8.250	0.500	inch	U5570
7.375	8.000	0.312	inch	U6355
7.500	8.000	0.250	inch	U5405
8.000	8.500	0.250	inch	U7013
8.250	8.750	0.250	inch	U6726

E3





NAK 標準型式

# WP1

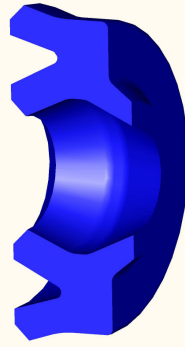
 應用環境：防塵(WIPER)  
 材質：聚氨酯(PU)

E4

尺寸			單位	圖號
軸徑	孔徑	高度		
0.375	0.687	0.194/0.245	inch	U5329
10	16	3.6/4.8	mm	U6590
10	18	5/6.5	mm	U4063
12	18	3.6/4.8	mm	U2920
0.500	0.812	0.194/0.245	inch	U5331
13	20	5/6.5	mm	U4064
14	20	4.8/3.6	mm	U3858
14	22	4.5/6	mm	U6131
0.625	0.937	0.194/0.245	inch	U5333
16	22	3.6/4.8	mm	U1660
16	24	4.5	mm	U6278
16	24	4.5/6	mm	U4145
16	24.3	4.5/6	mm	U1288
18	24	4.8/3.6	mm	U2719
18	26	4.5/6	mm	U3306
0.750	1.062	0.194/0.245	inch	U5335
20	25	4.5/5.8	mm	U6279
20	26	3.6/4.8	mm	U1949
20	28	4.5/6	mm	U3307
20	28	5/6.8	mm	U1162
22	28	3.6/4.8	mm	U2285
22	30	4.5	mm	U5671
22	30	4.5/6	mm	U5685
22	30	5/6.8	mm	U6603
22	30.6	4.4/5.8	mm	U7776
0.875	1.250	0.205/0.265	inch	U5337
22.4	30.4	4.5/5.8	mm	U6148
22.4	30.4	4.5/6	mm	U1289
24	32	4.8/6	mm	U6750
25	31	3.6/4.8	mm	U3031
25	31	4.5/6	mm	U6123
25	33	4.5/6	mm	U2315
25	33	4.8/6	mm	U6149
25	33	5/6.8	mm	U6592
1.000	1.375	0.205/0.265	inch	U5339
28	36	4.5	mm	U3308

尺寸			單位	圖號
軸徑	孔徑	高度		
28	36	4.5/5.8	mm	U2463
28	36	4.5/6	mm	U3308
28	36	4.8/6	mm	U6757
28	36	5/6.8	mm	U3279
1.125	1.500	0.205/0.265	inch	U5341
30	38	5	mm	U2884
30	38	4.5/5.8	mm	U3532
30	38	4.8/6	mm	U5879
30	38	5.8/4.5	mm	A0568
30	38	5/6.5	mm	U0981
30	38	5/6.8	mm	U6606
1.187	1.562	0.205/0.265	inch	U5342
31.5	39.5	5/6.5	mm	U6262
31.5	39.5	5/6.8	mm	U6277
1.250	1.625	0.205/0.265	inch	U5343
32	40	4.8/6	mm	U6751
32	40	5.8/4.5	mm	U2374
32	40	5/6.5	mm	U4616
32	40	5/6.8	mm	U2921
1.375	1.750	0.205/0.265	inch	U5345
35	43	3.5/5	mm	U7809
35	43	5/6.5	mm	U3118
35	43	5/6.8	mm	U2630
35.5	43.5	5/6.5	mm	U4146
36	44	4.5/5.8	mm	U2851
36	44	5/6.8	mm	U3859
38	46	5/6.5	mm	U7324
1.500	1.875	0.205/0.265	inch	U5347
40	48	5	mm	U2720
40	48	4.65/5.95	mm	U7553
40	48	5.8/4.5	mm	U2296
40	48	5/6.5	mm	U2314
40	48	5/6.8	mm	U1163
1.625	2.000	0.205/0.265	inch	U5349
1.750	2.125	0.205/0.265	inch	U5351
45	52.5	5/7.2	mm	U8156

NAK 標準型式

# WP1

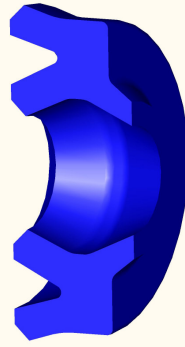
 應用環境：防塵(WIPER)  
 材質：聚氨酯(PU)

尺寸			單位	圖號
軸徑	孔徑	高度		
45	53	4.5/5.8	mm	U3467
45	53	5.8/4.5	mm	A0572
45	53	5/6.5	mm	U3852
45	55	5/6.8	mm	U2333
1.875	2.250	0.205/0.265	inch	U5353
50	58	4.5/5.8	mm	U6589
50	58	5/6.5	mm	U2313
50	58	5/6.8	mm	U6604
50	60	5/6.8	mm	U1421
2.000	2.375	0.205/0.265	inch	U5355
53	61	5/6.5	mm	U6313
2.125	2.500	0.205/0.265	inch	U5357
55	63	5/6.5	mm	U6314
55	63	5/6.8	mm	U6596
55	65	5/6.8	mm	U3635
56	64	5/6.5	mm	U3309
56	64	5/6.8	mm	U6607
56	66	5.3/6.8	mm	U3113
56	66	6.8/5.3	mm	A0573
2.250	2.750	0.268	inch	U5359
60	68	5/6.5	mm	U4617
60	68	5/6.8	mm	U6044
60	70	5/6.8	mm	U3210
2.375	2.875	0.268	inch	U5361
63	71	5/6.5	mm	U1296
63	71	5/6.8	mm	U6593
63	73	5/6.8	mm	U6588
2.500	3.000	0.268/0.325	inch	U5363
65	73	5/6.45	mm	U8144
65	73	5/6.5	mm	U1297
65	73	5/6.8	mm	U6636
65	75	5/6.8	mm	U2721
2.625	3.125	0.268/0.325	inch	U5365
68	78	5/6.8	mm	U7353
2.750	3.250	0.268/0.325	inch	U5367
70	78	5/6.8	mm	U5777

尺寸			單位	圖號
軸徑	孔徑	高度		
70	80	5/6.8	mm	U3008
70	80	6/8	mm	U2312
71	81	6/8	mm	U5793
2.875	3.375	0.268/0.325	inch	U5369
75	83	5/6.8	mm	U6644
75	85	5/7	mm	U6602
75	85	6/8	mm	U5623
75	87	7/9	mm	U2384
3.000	3.500	0.268/0.325	inch	U5371
78	88	7/9	mm	U7466
3.125	3.625	0.268/0.325	inch	U5372
80	90	5.3/6.8	mm	U7240
80	90	6.8/5.3	mm	U2722
80	90	6/8	mm	U3311
80	92	7/9	mm	U4152
82	94	7/9	mm	U7465
3.250	3.750	0.268/0.325	inch	U5373
85	95	6/8	mm	U6752
85	97	7/10	mm	U1157
85	97.2	7.1/10	mm	U7727
3.375	3.875	0.268/0.325	inch	U5374
3.500	4.000	0.268/0.325	inch	U5376
90	100	6.8/5.3	mm	U2668
90	100	6/8	mm	U3310
90	102	7/9	mm	U1158
3.625	4.125	0.268/0.325	inch	U5377
3.687	4.187	0.268/0.325	inch	U5378
95	105	6/8	mm	U7922
95	107	7/9	mm	U1156
3.750	4.250	0.268/0.325	inch	U5379
3.875	4.375	0.268/0.325	inch	U5380
100	110	6/8	mm	U1514
100	112	7/9	mm	U6605
4.000	4.500	0.268/0.325	inch	U5381
104	116	7/9	mm	U7317
4.125	4.625	0.268/0.325	inch	U5382

E4







NAK 標準型式

# WP3

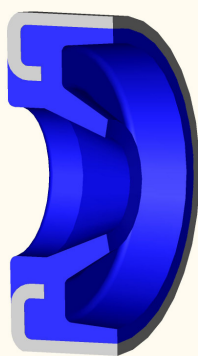
 應用環境：防塵(WIPER)  
 材質：聚氨酯(PU)

E4

尺寸			單位	圖號
軸徑	孔徑	高度		
0.625	1.125	0.312	inch	U5102
16	23	5	mm	U2727
16	24	2.8	mm	U5905
16	26	7	mm	U4596
0.750	1.250	0.312	inch	U5017
20	28	5	mm	U7011
20	30	7	mm	U4597
0.875	1.375	0.312	inch	U4537
0.875	1.375	0.313	inch	U0235
25	32	7	mm	U1246
25	35	4	mm	U5673
25	38	7.5	mm	U2947
1.000	1.250	0.125	inch	U5797
1.000	1.375	0.187	inch	U5664
1.000	1.500	0.312	inch	U4541
1.125	1.625	0.312	inch	U4485
30	38	5	mm	U7532
30	40	4	mm	U4211
30	40	7	mm	U5101
30	43	7.5	mm	U0883
30	45	4	mm	U5897
1.187	1.625	0.250	inch	U5248
1.250	1.687	0.187	inch	U4652
1.250	1.750	0.187	inch	U8089
1.250	1.750	0.250	inch	U5877
1.250	1.750	0.312	inch	U4542
1.250	1.750	0.313	inch	U0149
1.250	2.062	0.312	inch	U5100
1.250	2.062	0.375	inch	U5033
1.375	1.750	0.187	inch	U5465
1.375	1.875	0.312	inch	U4464
35	45	4	mm	U4454
35	50	7.5	mm	U0882
36	46	7	mm	U2724
38	50	7.5	mm	U3861
1.500	1.875	0.187	inch	U5665

尺寸			單位	圖號
軸徑	孔徑	高度		
1.500	1.875	0.250	inch	U5818
1.500	2.000	0.250	inch	U2761
1.500	2.000	0.312	inch	U3332
1.500	2.125	0.312	inch	U4538
1.500	2.250	0.250	inch	U5466
1.500	2.250	0.375	inch	U4477
40	50	3.18	mm	U5902
40	50	4	mm	U4455
40	50	5	mm	U5614
40	50	7	mm	U4462
40	50	8	mm	U7410
40	50	9	mm	U4474
40	52	6	mm	U6559
40	52	7	mm	U4394
40	55	9	mm	U4463
1.625	2.125	0.250	inch	U5262
1.625	2.125	0.312	inch	U5263
44	61.9	10	mm	U3821
1.750	2.125	0.125	inch	U5836
1.750	2.250	0.187	inch	U4482
1.750	2.250	0.250	inch	U3762
1.750	2.250	0.312	inch	U5264
1.750	2.250	0.313	inch	U0233
1.750	2.437	0.375	inch	U4478
44.45	61.94	9.52	mm	U5428
1.750	2.500	0.375	inch	U4465
45	55	3.18	mm	U6878
45	55	3.2	mm	U4522
45	55	4	mm	U4456
45	55	4.5	mm	U5662
45	55	5	mm	U0217
45	55	6	mm	U5756
45	57	7	mm	U4518
45	60	5	mm	U5757
45	60	7.5	mm	U3517
1.875	2.375	0.250	inch	U0833

NAK 標準型式

# WP3

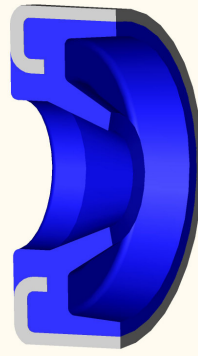
 應用環境：防塵(WIPER)  
 材質：聚氨酯(PU)

尺寸			單位	圖號
軸徑	孔徑	高度		
1.875	2.375	0.312	inch	U5265
1.875	2.562	0.375	inch	U5467
50	60	4	mm	U4548
50	60	4.2	mm	U3521
50	60	4.5	mm	U5882
50	60	5	mm	U3105
50	60	6	mm	U5900
50	60	7	mm	U2725
50	62	7	mm	U3853
50	63	5	mm	U5610
50	63	7.5	mm	U7511
50	64	8	mm	U5247
50	65	5	mm	U5675
50	65	6	mm	U5901
50	65	7.5	mm	U2997
50	65	9	mm	U4475
2.000	2.375	0.187	inch	U5250
2.000	2.375	0.250	inch	U5261
2.000	2.500	0.250	inch	U4746
2.000	2.500	0.312	inch	U3336
2.000	2.625	0.250	inch	U5817
2.000	2.686	0.375	inch	U4479
2.000	2.688	0.313	inch	U3007
2.000	2.750	0.375	inch	U4480
51.5	66	4.75	mm	RD042
2.125	2.500	0.125	inch	U5816
2.125	2.625	0.250	inch	U5837
2.125	2.625	0.313	inch	U5838
2.125	2.875	0.375	inch	U4615
55	65	3.2	mm	U4769
55	65	5	mm	U4461
55	65	7	mm	U4492
55	68	6	mm	U5629
55	69	8	mm	U3854
55	70	5	mm	U5895
55	70	6	mm	U5674

尺寸			單位	圖號
軸徑	孔徑	高度		
55	70	7.5	mm	U3419
56	68	7	mm	U6477
56	70	7.5	mm	U5898
56	71	9	mm	U4483
2.250	2.750	0.187	inch	U5815
2.250	2.750	0.250	inch	U5260
2.250	2.750	0.312	inch	U4539
2.250	2.750	0.313	inch	U0234
2.250	2.997	0.375	inch	U4473
2.250	3.000	0.250	inch	U5246
2.250	3.000	0.375	inch	U4643
2.345	2.727	0.210/0.226	inch	U1374
60	70	5	mm	U3266
60	70	7	mm	U6581
60	73	6	mm	U5245
60	73	8	mm	U6515
60	74	8	mm	U3044
60	75	4	mm	U5653
60	75	5	mm	U5422
60	75	6	mm	U5642
60	75	7	mm	U4536
60	75	7.5	mm	U3106
60	75	8	mm	U2833
2.375	2.875	0.312	inch	U4481
2.375	3.125	0.375	inch	U5814
63	75	7	mm	U4466
63	78	7.5	mm	U4312
63	78	9	mm	U4484
63	83	10	mm	U6516
2.500	3.000	0.187	inch	U4654
2.500	3.000	0.250	inch	U5360
2.500	3.000	0.312	inch	U3335
2.500	3.000	0.375	inch	U5259
2.500	3.250	0.250	inch	U5813
2.500	3.250	0.375	inch	U4505
2.500	3.500	0.375	inch	U5803

E4

NAK 標準型式

# WP3

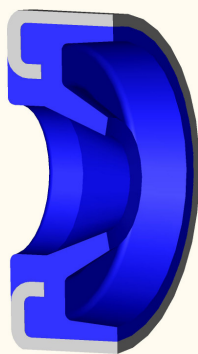
 應用環境：防塵(WIPER)  
 材質：聚氨酯(PU)

E4

尺寸			單位	圖號
軸徑	孔徑	高度		
65	75	7	mm	U3855
65	79	8	mm	U3856
65	80	5	mm	U5644
65	80	7.5	mm	U2250
65	80	8	mm	U5881
2.625	3.125	0.250	inch	U5106
2.734	3.250	0.313	inch	U4067
2.739	3.125	0.210/0.226	inch	U1375
2.750	3.250	0.187	inch	U5827
2.750	3.250	0.312	inch	U5258
2.750	3.250	0.313	inch	U0526
2.750	3.500	0.375	inch	U4467
2.750	3.750	0.500	inch	U5820
70	80	5	mm	U7847
70	80	7	mm	U3857
70	80	8	mm	U7839
70	84	7.5	mm	U1728
70	84	8	mm	U0936
70	85	5	mm	U5643
70	85	7	mm	U4543
70	85	7.5	mm	U2251
70	85	8	mm	U8106
70	85	10	mm	U5464
71	86	5	mm	U5628
71	86	6	mm	U5880
75	89	8	mm	U4201
75	90	6	mm	U5963
75	90	7.5	mm	U2441
75	90	8	mm	U5631
3.000	3.500	0.312	inch	U3334
3.000	3.750	0.250	inch	U5822
3.000	3.750	0.375	inch	U4493
3.000	4.000	0.500	inch	U4501
3.125	3.750	0.375	inch	U5865
3.131	3.518	0.210	inch	U1376
80	90	3.18	mm	U4523

尺寸			單位	圖號
軸徑	孔徑	高度		
80	90	4.5	mm	U5741
80	90	6	mm	U7273
80	90	7	mm	U3445
80	90	8	mm	U7838
80	94	4	mm	U5856
80	94	8	mm	U2391
80	95	5	mm	U3303
80	95	6	mm	U5742
80	95	7.5	mm	U2397
80	95	8	mm	U3642
80	100	10	mm	U4046
3.250	3.750	0.312	inch	U4502
3.250	3.875	0.312	inch	U4668
3.250	4.250	0.500	inch	U4540
85	95	5	mm	U6742
85	95	7	mm	U7742
85	95	8	mm	U7837
85	99	8	mm	U2852
85	100	4	mm	U8229
85	100	6	mm	U5097
85	100	8	mm	U5419
85	100	10	mm	U7603
85	105	10	mm	U3518
3.375	4.000	0.312	inch	U4745
3.500	4.000	0.312	inch	U4494
88.9	101.6	9.52	mm	U7208
3.500	4.000	0.375	inch	U0827
3.500	4.125	0.312	inch	U3333
88.9	107.95	7.93	mm	U5641
3.500	4.500	0.500	inch	U5034
3.528	3.920	0.210/0.226	inch	U1377
90	100	7	mm	U2787
90	100	8	mm	U7836
90	104	8	mm	U3088
90	105	6	mm	U2981
90	105	7	mm	U5249



NAK 標準型式

# WP3

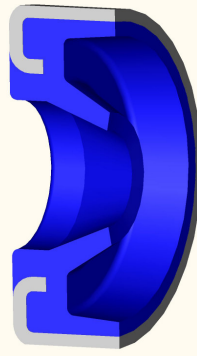
 應用環境：防塵(WIPER)  
 材質：聚氨酯(PU)

尺寸			單位	圖號
軸徑	孔徑	高度		
90	105	8	mm	U8260
90	106	8	mm	U2784
90	110	7	mm	U4506
90	110	8	mm	U0734
90	110	10	mm	U2442
95	109	8	mm	U5423
95	110	6	mm	U6176
95	110	8	mm	U4549
95.25	107.95	9.52	mm	U7005
3.750	4.250	0.375	inch	U0826
3.750	4.375	0.312	inch	U4653
3.750	4.500	0.312	inch	U4495
3.750	4.750	0.500	inch	U5823
100	110	7	mm	U6533
100	110	8	mm	U7832
100	114	8	mm	U3328
100	115	6	mm	U5984
100	115	6.5	mm	U4532
100	115	7	mm	U4496
100	115	7.5	mm	U2982
100	115	8	mm	U8104
100	115	9	mm	U1987
100	116	8	mm	U2785
100	120	4	mm	U6000
100	120	6.5	mm	U8107
100	120	7	mm	U7749
100	120	8	mm	U0736
100	120	10	mm	U2325
4.000	4.500	0.312	inch	U5796
101.6	114.3	9.52	mm	U7019
4.000	4.5000	0.375	inch	U0825
4.000	4.625	0.312	inch	U4533
4.000	4.750	0.312	inch	U5098
4.000	5.000	0.500	inch	U5103
105	120	7	mm	U6608
105	120	8	mm	U5420

尺寸			單位	圖號
軸徑	孔徑	高度		
4.250	4.750	0.187	inch	U4650
4.250	4.750	0.312	inch	U5318
4.250	4.875	0.312	inch	U4498
110	120	7	mm	U7335
110	120	8	mm	U7833
110	125	4	mm	U5904
110	125	8	mm	U4500
110	125	9	mm	U4019
110	126	8	mm	U2783
110	126	9	mm	U2694
110	130	8	mm	U5096
110	130	9	mm	U3523
110	130	10	mm	U2983
110	140	8	mm	U7505
4.500	5.125	0.312	inch	U4651
4.500	5.250	0.312	inch	U4667
4.500	5.500	0.500	inch	U5105
115	130	8	mm	U4314
115	135	8	mm	U5850
120	130	7	mm	U7114
120	130	8	mm	U7834
120	135	8	mm	U2365
120	136	9	mm	U0939
120	140	8	mm	U2655
120	140	10	mm	U4519
120	150	12	mm	U4395
125	140	8	mm	U5421
125	140	9	mm	U4535
125	145	8	mm	U7008
5.000	5.625	0.312	inch	U4534
5.000	5.750	0.312	inch	U4497
5.000	6.000	0.500	inch	U5099
130	145	7.5	mm	U2678
130	146	9	mm	U0937
130	150	7.5	mm	U1510
130	150	8	mm	U3803

E4

NAK 標準型式

# WP3

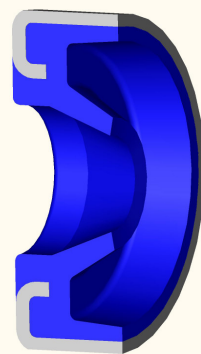

應用環境：防塵(WIPER)  
材質：聚氨酯(PU)

E4

尺寸			單位	圖號
軸徑	孔徑	高度		
130	150	9	mm	U5215
130	150	10	mm	U4425
130	154	8	mm	U3268
130	155	8	mm	U8108
130	155	10	mm	U5849
130	160	12	mm	U4396
5.250	5.750	0.312	inch	U5663
5.500	6.125	0.375	inch	U4503
5.500	6.250	0.312	inch	U5824
140	155	8	mm	U7848
140	160	8	mm	U7829
140	160	10	mm	U3468
140	162	7.5	mm	U5122
140	164	8	mm	U7789
140	165	8	mm	U7280
140	170	8	mm	U5266
140	170	12	mm	U7781
145	160	10	mm	U7830
5.750	6.375	0.375	inch	U5104
150	165	8	mm	U5276
150	170	10	mm	U5132
150	175	8	mm	U5267
150	175	9	mm	U2366
150	180	10	mm	U7215
6.000	6.625	0.375	inch	U4468
6.000	6.750	0.375	inch	U4499
160	175	10	mm	U7007
160	180	5	mm	U8071
160	180	8	mm	U7831
160	180	10	mm	U3267
160	184	8	mm	U5277
160	190	9	mm	U2367
160	190	10	mm	U5268
6.500	7.250	0.312	inch	U5825
170	190	8	mm	U5630
170	190	9	mm	U2368

尺寸			單位	圖號
軸徑	孔徑	高度		
170	200	10	mm	U2369
175	195	10	mm	U5667
7.000	7.750	0.312	inch	U4504
7.000	8.000	0.500	inch	U5826
180	195	9	mm	U6280
180	200	10	mm	U4397
200	220	10	mm	U8289
200	225	12	mm	U6729
8.000	8.750	0.375	inch	U4744
215	240	10	mm	U5676
220	240	16	mm	U5209
230	250	12	mm	U5317

NAK 標準型式

# WP4

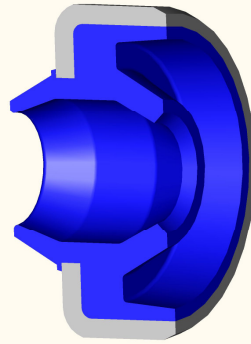
 應用環境：防塵(WIPER)  
 材質：聚氨酯(PU)

尺寸			單位	圖號
軸徑	孔徑	高度		
18	30	6	mm	U5762
19	26	5/7	mm	U1834
19	27	4/6	mm	U8085
19.3	26.1	5/7	mm	U7655
20	32	6/9	mm	U3149
22	34	6/9	mm	U6539
25	37	6/9	mm	U2695
25.4	38	6/9	mm	U4476
25.6	34.8	4.9/5.6	mm	U7301
30	42	6/9	mm	U2558
32	44	7/10	mm	U2548
34	46	7/10	mm	U0523
35	47	7/10	mm	U2252
35	55	7/10	mm	U5293
36	48	7/10	mm	U6600
38	50	7/10	mm	U4414
40	52	7/10	mm	U2396
40	55	7/10	mm	U8131
40	60	7/10	mm	U5291
45	57	7/10	mm	U2297
45	65	7/10	mm	U5294
50	62	7/10	mm	U3107
50	62	8/12	mm	U7673
50	65	7/10	mm	U8134
50	72	8/11	mm	U6601
55	69	8/11	mm	U3097
55	69	8/12	mm	U7390
55	75	7/10	mm	U5295
60	74	8/11	mm	U3022
60	74	8/12	mm	U7387
63	77	8/11	mm	U5308
65	79	8/11	mm	U2676
65	79	8/12	mm	U7388
65	79	8/13	mm	U6977
65	85	7/10	mm	U5296
70	83	8/11	mm	U3278

尺寸			單位	圖號
軸徑	孔徑	高度		
70	84	8/11	mm	U2443
70	84	8/12	mm	U7392
70	84	8/13	mm	U6894
70	85	7/10	mm	U8132
75	89	8/11	mm	U2392
75	89	8/12	mm	U7389
80	94	8/11	mm	U8266
80	94	8/12	mm	U2350
80	94	8/13	mm	U6895
85	99	8/11	mm	U2677
85	99	8/12	mm	U7384
85	99	8/13	mm	U6896
90	104	8/11	mm	U3023
90	104	8/12	mm	U7748
90	104	8/13	mm	U6976
95	109	8/11	mm	U0514
95	109	8/12	mm	U7385
95	109	8/13	mm	U6893
100	114	8/11	mm	U0515
100	114	8/12	mm	U7678
100	114	8/13	mm	U6870
105	121	8/12	mm	U7679
105	121	9/12	mm	U2998
110	126	9/12	mm	U2950
110	126	9/12.5	mm	U7680
115	131	9/12	mm	U3569
115	131	9/12.5	mm	U7672
120	136	9/12	mm	U3150
130	146	9/12	mm	U3151
140	160	10/14	mm	U2835
145	160	10/14	mm	U5659
165	185	10/14.5	mm	U5041
200	216	8/11	mm	U5040
200	225	12/17	mm	U5043
8.125	8.821	0.375/0.500	inch	U6181
210	230	12/17	mm	U5743

E4



NAK 標準型式

# WP5

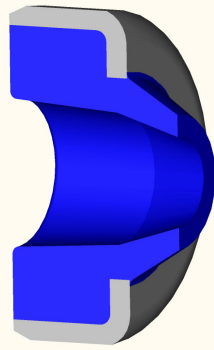
 應用環境：防塵(WIPER)  
 材質：聚氨酯(PU)

尺寸			單位	圖號
軸徑	孔徑	高度		
8	14	3.5/5	mm	U3820
8	14	3/5	mm	U6578
8	18	5/7	mm	U2758
9	19	5/7	mm	U8293
10	16	3.5/5	mm	U5979
10	20	5/8	mm	U2551
12	18	3.5/5	mm	U7079
12	18	3/5	mm	U6577
12	20	4/6	mm	U2352
12	22	5/8	mm	U3086
14	20	3.5/5	mm	U2689
14	22	3/4	mm	U7275
14	24	5/7	mm	U4580
14	25	5/8	mm	U7503
15	21	3.5/5	mm	U4399
15	25	5/8	mm	U0638
16	22	3.5/5	mm	U1694
16	22	3/4	mm	U2667
16	26	5/8	mm	U2907
17	24	3.5/5	mm	U2673
18	28	5/7	mm	U1729
18	28	5/8	mm	U3843
18	28	7/10	mm	U3937
18	30	6/9	mm	U2759
19	26	5	mm	U3033
19	26	5/7	mm	U5539
19	27	6.4/9.5	mm	U1978
20	28	3.5/5	mm	U2781
20	30	4/6	mm	U2674
20	30	5/8	mm	U2326
20	30	7/10	mm	U2240
20	32	6/9	mm	U2373
20	32	7/10	mm	U3290
22	28	5/8	mm	U5978
22	32	5/8	mm	U4792
22	32	7/10	mm	U3928

尺寸			單位	圖號
軸徑	孔徑	高度		
25	32	5/8	mm	U2229
25	35	5/8	mm	U4273
25	35	7/10	mm	U2690
25	35	7/9	mm	U7181
25	37	6/9	mm	U4392
25.4	38	6/9	mm	U5540
27	39	6/9	mm	U1325
28	38	5/8	mm	U3844
28	38	7/10	mm	U3804
28	40	6/9	mm	U1326
28	40	7/10	mm	U5325
28	40.1	6/9.5	mm	U4814
28	42	7/10	mm	U5604
30	40	5/8	mm	U3211
30	40	7/10	mm	U3273
30	42	5/8	mm	U0966
30	42	6/9	mm	U4252
30	45	5/8	mm	U0064
30	47	7/10	mm	U0967
32	40	4/7	mm	U5723
32	42	5/8	mm	U3845
32	42	7/10	mm	U2786
32	44	7/10	mm	U3198
32	45	4/6	mm	U2934
32	45	7/10	mm	U2691
33	43	7/10	mm	U5977
35	45	7/10	mm	U3277
35	47	7/10	mm	U3798
36	45	7/10	mm	U2245
36	46	5/7	mm	U5976
36	46	7/10	mm	U2935
36	50	7/10	mm	U3846
38	48	7/10	mm	U4393
38	50	7/10	mm	U1328
40	50	7	mm	U1897
40	50	5/8	mm	U3630

E4



NAK 標準型式

# WP5

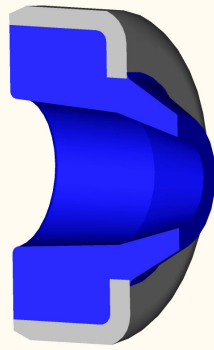
 應用環境：防塵(WIPER)  
 材質：聚氨酯(PU)

E4

尺寸			單位	圖號
軸徑	孔徑	高度		
40	50	7/10	mm	U2454
40	52	7/10	mm	U2517
40	60	7/10	mm	U0202
42	52	5/8	mm	U5975
42	52	7/10	mm	U0843
45	55	5/8	mm	U5794
45	55	7/10	mm	U2755
45	57	7/10	mm	U2232
45	60	7/10	mm	U3104
47	59	7/10	mm	U3503
48	60	7/10	mm	U3790
48	62	7/10	mm	U7077
50	56	5/8	mm	U2996
50	60	5/8	mm	U4992
50	60	7/10	mm	U2228
50	62	7/10	mm	U3199
50	65	7/10	mm	U0965
52	62	7/10	mm	U0853
53	67	8/11	mm	U1331
55	63	7/10	mm	U3428
55	65	5/8	mm	U2057
55	65	7/10	mm	U2233
55	69	8/11	mm	U2669
56	66	5/8	mm	U5973
56	66	7/10	mm	U2550
56	70	8/11	mm	U1333
60	70	5/8	mm	U5972
60	70	7/10	mm	U2253
60	74	5/8	mm	U2670
60	74	8/11	mm	U1334
60	75	7/10	mm	U0964
63	73	5/8	mm	U3516
63	73	7/10	mm	U1887
63	75	7/10	mm	U2631
63	77	8/11	mm	U2937
63	78	7/10	mm	U5896

尺寸			單位	圖號
軸徑	孔徑	高度		
64	78	8/11	mm	U1336
65	75	5/8	mm	U5971
65	75	7/10	mm	U2455
65	79	8/11	mm	U3847
67	81	8/11	mm	U1337
70	80	5/8	mm	U5981
70	80	7/10	mm	U2760
70	84	8/11	mm	U2671
71	85	8/11	mm	U4521
75	83	7/10	mm	U5983
75	85	7/10	mm	U2456
75	89	8/11	mm	U5500
80	88	7/10	mm	U5982
80	90	7/10	mm	U2254
80	94	8/11	mm	U2672
82	92	7/10	mm	U4253
85	95	7/10	mm	U2675
85	99	8/11	mm	U3187
90	100	7/10	mm	U2094
90	104	8/11	mm	U1341
90	110	10/14	mm	U2757
92	106	8/11	mm	U1342
95	105	7/10	mm	U2095
95	109	8/11	mm	U5430
100	110	7/10	mm	U2834
100	114	8/11	mm	U2518
100	115	8/11	mm	U2693
105	115	7/10	mm	U2410
105	121	9/12	mm	U1344
106	122	9/12	mm	U6595
110	120	7/10	mm	U2880
110	126	9/12	mm	U2244
110	130	7/10	mm	U6583
112	128	9/12	mm	U1347
115	125	7/10	mm	U4254
115	131	9	mm	U5045













NAK 標準型式

# WP11

 應用環境：防塵(WIPER)  
 材質：聚氨酯(PU)

E4

尺寸			單位	圖號
軸徑	孔徑	高度		
1.000	1.500	0.313	inch	U0372
1.125	1.625	0.312	inch	U4224
30	38	5	mm	U5208
1.250	1.687	0.187	inch	U1858
1.250	1.750	0.313	inch	U0373
1.375	1.875	0.312	inch	U4233
35	45	7	mm	U3898
1.500	2.000	0.250	inch	
1.500	2.000	0.312	inch	U4212
1.500	2.250	0.375	inch	U4209
40	50	7	mm	U3897
40	50	9	mm	U4219
40	52	4.2	mm	U2953
40	55	9	mm	U4459
1.750	2.437	0.375	inch	U3054
1.750	2.500	0.375	inch	U4234
45	55	7	mm	U3899
50	60	7	mm	U3900
50	65	7.5	mm	U7747
50	65	9	mm	U4220
2.000	2.375	0.187	inch	U1857
2.000	2.500	0.312	inch	U4225
2.000	2.500	0.313	inch	U4943
2.000	2.686	0.375	inch	U4247
2.000	2.750	0.375	inch	U4248
52	68	6	mm	U2453
55	65	5	mm	U4457
55	65	7	mm	U4231
56	71	9	mm	U4221
56	72	6.5	mm	U1954
2.250	2.997	0.375	inch	U4240
60	74	8	mm	U0371
60	75	7.5	mm	U7808
2.375	2.875	0.312	inch	U4249
63	75	7	mm	U4236
63	78	9	mm	U4222

尺寸			單位	圖號
軸徑	孔徑	高度		
2.500	3.000	0.313	inch	U0374
2.500	3.250	0.375	inch	U5326
65	80	5	mm	U0370
2.750	3.250	0.313	inch	U3519
2.750	3.500	0.375	inch	U4458
70	80	7	mm	U3901
70	84	8	mm	U4942
3.000	3.500	0.313	inch	U3053
3	3.75	0.313	inch	U6964
3.000	3.750	0.375	inch	U3051
3.000	4.000	0.500	inch	U4250
80	90	7	mm	U3902
80	95	6	mm	U7807
80	95	8	mm	U7109
3.250	3.750	0.312	inch	U4251
3.250	3.750	0.313	inch	U3052
85	99	8	mm	U7707
85	100	8	mm	U7786
3.500	4.000	0.312	inch	U4227
3.500	4.000	0.313	inch	U0377
3.500	4.125	0.312	inch	U4228
90	100	7	mm	U4232
90	105	8	mm	U7723
90	106	8	mm	U2841
90	110	7	mm	U4229
3.750	4.500	0.312	inch	U4239
3.750	4.500	0.313	inch	U2379
100	114	8	mm	U5714
100	115	7	mm	U4218
100	116	8	mm	U2840
100	120	8	mm	U7112
4.250	4.875	0.312	inch	U4237
110	125	8	mm	U4241
110	130	10	mm	U7806
115	130	7.5	mm	U7688
115	135	8	mm	U7687





NAK 標準型式

# WP21

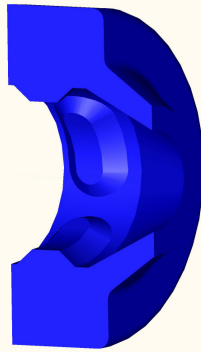

應用環境：防塵(WIPER)  
 材質：聚氨酯(PU)

尺寸			單位	圖號
軸徑	孔徑	高度		
125	137	7/12	mm	U4442
14	20	3.5/5.3	mm	U4695
20	28	5/7	mm	U4441
20	28.6	5.3/6.5	mm	U4817
25	33.6	5.3/6.5	mm	U4818
30	38.6	5.3/6.5	mm	U4815
30	38.6	4.7/6.5	mm	U7811
30	38.6	4.7/6.7	mm	RD078
45	53.6	4.7/6.5	mm	U7798
75	87.2	6.9/12	mm	U7799
110	125	9.5/14	mm	U5834

尺寸			單位	圖號
軸徑	孔徑	高度		

E4







NAK 標準型式

# WPB

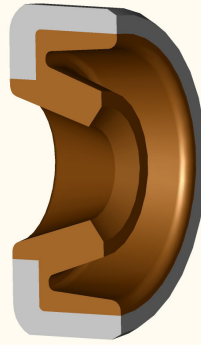

應用環境：防塵(WIPER)  
 材質：丁腈橡膠(NBR)  
 氟素橡膠(FKM)

**E4**

尺寸			單位	圖號
軸徑	孔徑	高度		
9	16	3.3	mm	U7176
0.375	0.563	0.094	inch	U5321
10	16	3.3	mm	U6984
12	16	3	mm	U8175
15	21	3.2	mm	U7778
16	26	7/9.5	mm	23530
0.750	1.250	0.313	inch	14877
20	28	4.7	mm	U7910
25	33	4.7	mm	U8078
25	35	4.8	mm	09147
1.000	1.500	0.313	inch	14876
1.063	1.500	0.187	inch	U1986
1.250	1.625	0.187	inch	U1985
1.125	1.625	0.188	inch	U3675
1.250	1.688	0.187	inch	U6753
1.250	1.750	0.250	inch	U8122
1.250	1.750	0.313	inch	15021
33	45	6.5/8	mm	
1.375	1.875	0.313	inch	14865
1.500	1.875	0.188	inch	
1.500	2.000	0.250	inch	
1.500	2.000	0.313	inch	14866
40	50	12	mm	28644
1.750	2.250	0.250	inch	
1.750	2.250	0.313	inch	14882
44.45	61.91	9.53	mm	U4764
45	55	3.18	mm	U5899
50	60	11.5	mm	23341
2.000	2.375	0.187	inch	U1984
2.000	2.500	0.250	inch	U4875
2.000	2.500	0.313	inch	14881
2.000	2.688	0.250	inch	U3650
52	62	7	mm	15100
2.125	2.500	0.188	inch	37945
2.250	2.750	0.250	inch	U4876
2.250	2.750	0.313	inch	U3677

尺寸			單位	圖號
軸徑	孔徑	高度		
60	70	5	mm	U7399
2.500	3.000	0.188	inch	U4846
2.500	3.000	0.313	inch	14880
63.5	82.55	9.52	mm	U4855
65	79	8	mm	A0503
65	80	5	mm	U4914
65	82.5	11.5	mm	23342
2.625	3.125	0.250	inch	U4847
69.85	82.55	6.35	mm	U7035
2.750	3.250	0.313	inch	U3678
70	85	4	mm	U6947
75	87	5	mm	U3409
3.000	3.500	0.313	inch	14879
80	90	3.18	mm	00775
80	95	4	mm	U6946
80	95	5	mm	U5737
3.250	3.750	0.313	inch	U4849
85	99	8	mm	A0502
3.500	4.000	0.310	inch	U7015
3.500	4.000	0.313	inch	U3676
3.500	4.125	0.313	inch	14878
3.500	4.250	0.313	inch	U4848
3.750	4.375	0.313	inch	U4850
100	114	8	mm	A0505
4.000	4.500	0.250	inch	14862
4.000	4.625	0.313	inch	U4851
4.000	4.750	0.313	inch	U4852
4.250	4.813	0.275	inch	08769
4.500	5.250	0.313	inch	U4853
115	135	6	mm	U7303
115	135	6/9	mm	U1556
4.750	5.375	0.313	inch	U4854
125	140	7	mm	U2495
125	168	18	mm	U5214
5.000	5.750	0.313	inch	21915
131	152.4	6.35	mm	05106









NAK 標準型式

# WPM

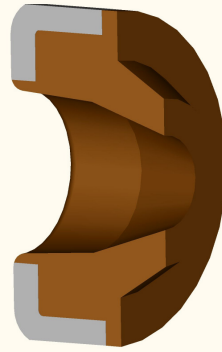

應用環境：防塵(WIPER)  
 材質：丁腈橡膠(NBR)  
 氟素橡膠(FKM)

E4

尺寸			單位	圖號
軸徑	孔徑	高度		
5	10	3/4	mm	U7509
6	13	3/4.5	mm	19528
6.3	13	3/4.5	mm	U4800
8	14	3.3/5	mm	U5956
8	15	3/5	mm	U6549
8	22	3/4.5	mm	21351
10	16	3.5/5	mm	U5809
10	16	3/4.5	mm	U1713
10	16	5/7	mm	18274
10	18	5/8	mm	U2986
10	20	4/6	mm	U3887
10	20	5/7	mm	U6586
10	20	5/8	mm	U4178
12	18	3.5/5	mm	U3885
12	18	3/4	mm	U4179
12	18	4/6	mm	U5918
12	20	4/6	mm	24186
12	22	5/8	mm	U1749
12	25	5/8	mm	U1681
12.7	18	3/4.5	mm	U4517
14	19.8	3/4.5	mm	U5957
14	20	3.5/5	mm	U5919
14	20	4/5	mm	13864
14	22	3/4	mm	U1771
14	25	5/8	mm	U1830
15	21	3.5/5	mm	U5920
15	23	4/7	mm	U2885
15	25	5/8	mm	21440
15	25	7/10	mm	U1680
16	20	3/4	mm	U5145
16	22	3.5/5	mm	U4180
16	22	3/4	mm	U1408
16	22	3/4.5	mm	19856
16	24	3/4	mm	U5917
16	26	5/8	mm	U1258
16	26	7/10	mm	15392

尺寸			單位	圖號
軸徑	孔徑	高度		
17	22	5/7	mm	09891
17	22	5/8	mm	U5320
18	26	3/4	mm	08157
18	26	4/6.5	mm	U7126
18	26	5/7	mm	07663
18	28	5/7	mm	U1896
18	28	7/10	mm	15409
18	28	7/12	mm	04970
18	32	5/8	mm	U5949
19	26	4/6	mm	U2408
19	26	5/8	mm	U6728
19	27	6.4/9.5	mm	U5580
19.05	25.4	3.17/5.55	mm	U1585
19.05	28.57	4.76/7.14	mm	07475
0.750	1.125	0.188/0.281	inch	15036
0.750	1.250	0.188/0.250	inch	09927
20	26	3.5/5	mm	U5958
20	26	4/7	mm	11457
20	26	5/8	mm	23603
20	27	7/10	mm	U1409
20	28	3.5/5	mm	23925
20	28	5/8	mm	U1554
20	30	4/6	mm	U5142
20	30	5/7	mm	U1699
20	30	5/8	mm	20362
20	30	7/10	mm	02170
20	35	7/10	mm	U1678
21	28	3.5/5	mm	U5950
21	28	3.5/5.5	mm	U4363
21	28	4.8/9	mm	U7766
22	28	5/8	mm	U4181
22	28	5/9	mm	U4005
22	30	4/6	mm	U5959
22	30	5/8	mm	23818
22	30	6/11	mm	U6690
22	32	4/6	mm	U1866

NAK 標準型式

# WPM

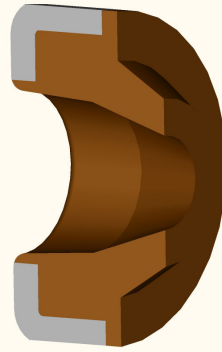

應用環境：防塵(WIPER)  
 材質：丁腈橡膠(NBR)  
 氟素橡膠(FKM)

尺寸			單位	圖號
軸徑	孔徑	高度		
22	32	5/8	mm	24156
22	32	7/10	mm	
22	35	5/8	mm	01706
0.875	1.250	0.188/0.281	inch	15037
23	33	5/8	mm	U5948
24	32	5/7	mm	18339
24	32	5/8	mm	U6587
24	35	5/8	mm	23726
24	35	7/10	mm	14354
25	31	5/7	mm	U2836
25	33	4/7	mm	U5767
25	35	3/4	mm	08156
25	35	5/7	mm	U5257
25	35	5/8	mm	
25	35	7/10	mm	U1370
25	35	7/8	mm	09649
25	35	7/8.8	mm	11074
25	37	6/9	mm	16894
25	43	5/7	mm	U3600
25.4	33.34	4.76/6.35	mm	U3025
1.000	1.313	0.187/0.250	inch	16377
25.4	34	5/8	mm	U1233
25.4	34.92	4.76/6.35	mm	U6591
1.000	1.375	0.187/0.250	inch	11078
1.000	1.375	0.188/0.281	inch	12029
1.000	1.375	0.219/0.297	inch	
26	34	5/8	mm	U4182
26	35	7/10	mm	13893
28	34	5/7	mm	08155
28	38	5/8	mm	U1727
28	38	7/10	mm	16893
28	40	7/10	mm	21287
28	45	7/10	mm	U5960
1.125	1.500	0.188/0.281	inch	09394
29.5	40	7/10	mm	09198
30	40	5/7	mm	09650

尺寸			單位	圖號
軸徑	孔徑	高度		
30	40	5/8	mm	20911
30	40	7/10	mm	U7033
30	42	5/8	mm	19920
30	42	7/10	mm	U1715
30	45	5/8	mm	08712
30	45	7/10	mm	U6971
1.250	1.625	0.188/0.281	inch	06659
1.250	1.625	0.210/0.290	inch	10842
32	40	4/7	mm	06440
32	40	7/10	mm	U1410
32	42	4/6	mm	U1704
32	42	5/7	mm	U1731
32	42	7/10	mm	21288
32	45	4/8	mm	U4183
32	45	5/8	mm	U1679
32	45	7/10	mm	20618
32	50	7/10	mm	U1695
35	45	5/7	mm	U4428
35	45	7/10	mm	U1186
35	47	7/10	mm	U5888
35	48	5/8	mm	22803
35	48	6.5/12	mm	U1576
35	50	9/12	mm	U1676
35	52	7/10	mm	U1675
36	45	7/10	mm	U1730
36	46	5/7	mm	U4184
36	46	7/10	mm	20646
37	47	5/8	mm	U1906
38	48	7/10	mm	24088
38	53	5/8	mm	U5018
1.500	1.875	0.188/0.281	inch	13957
1.500	1.875	0.219/0.297	inch	
39.5	50	7/10	mm	09199
40	50	3.5/5	mm	U1712
40	50	5/10	mm	11928
40	50	5/7	mm	U2729

E4

NAK 標準型式

# WPM

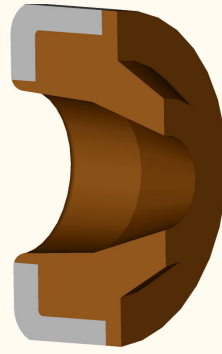

應用環境：防塵(WIPER)  
 材質：丁腈橡膠(NBR)  
 氟素橡膠(FKM)

E4

尺寸			單位	圖號
軸徑	孔徑	高度		
40	50	5/8	mm	05073
40	50	7/10	mm	24189
40	52	5/8	mm	U4185
40	52	7/10	mm	19216
40	53	5/8	mm	U7244
40	55	9/12	mm	U1677
40	62	7/10	mm	24515
42	52	5/7	mm	U5921
42	52	7/10	mm	30525
44	55	5/8	mm	24513
1.750	2.125	0.188/0.281	inch	06657
1.750	2.125	0.219/0.290	inch	18606
45	55	5/7	mm	U4186
45	55	7/10	mm	U2845
45	57	7/10	mm	22692
45	60	7/10	mm	
47	57	7/10	mm	16822
48	60	7/10	mm	23727
50	56	4/6	mm	U1674
50	56	5/7	mm	24187
50	56	5/8	mm	U7128
50	60	5/7	mm	13016
50	60	5/8	mm	U1189
50	60	7/10	mm	U4864
50	62	5/7	mm	U6585
50	62	7/10	mm	U6998
50	63	7/10	mm	U2584
50	63	8/10	mm	09646
50	65	5/7	mm	16904
50	65	5/8	mm	U1702
50	65	7/10	mm	
50	65	8/10	mm	09645
50	70	7/10	mm	12178
50	72	8/11	mm	
2.000	2.375	0.188/0.281	inch	06658
52	62	7/10	mm	

尺寸			單位	圖號
軸徑	孔徑	高度		
55	63	7/10	mm	
55	65	5/7	mm	
55	65	5/8	mm	
55	65	7/10	mm	U2923
55	70	7/10	mm	U6597
55	80	5/8	mm	24315
56	65	7/10	mm	U1673
56	66	5/7	mm	U6674
56	66	7/10	mm	23728
56	70	8/10	mm	U6584
2.250	2.625	0.188/0.281	inch	07674
60	68	5/8	mm	U5234
60	70	5/7	mm	14920
60	70	7/10	mm	U1930
60	70	8/10	mm	09644
60	74	5/8	mm	U1732
60	75	7/10	mm	21439
60	80	7/10	mm	U1719
62	72	7/10	mm	21098
63	73	5	mm	U5922
63	73	7/10	mm	U1716
63	75	7/10	mm	14475
63	83	5/8	mm	U5753
2.500	2.875	0.188/0.281	inch	07675
65	75	5/7	mm	U4187
65	75	7/10	mm	U1419
70	80	5/7	mm	09896
70	80	7/10	mm	35828
70	84	7/10	mm	U7403
70	90	7/10	mm	22095
72	82	7/10	mm	U6339
73	89	7/10	mm	24316
74	85	7/10	mm	U2624
75	85	7/10	mm	U6975
78	88	7/10	mm	13573
80	88	7/10	mm	U5752



NAK 標準型式

# WPR

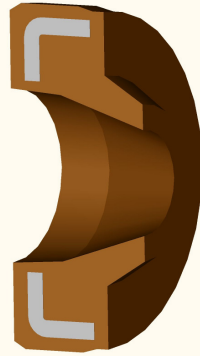

應用環境：防塵(WIPER)  
 材質：丁腈橡膠(NBR)  
 氟素橡膠(FKM)

E4

尺寸			單位	圖號
軸徑	孔徑	高度		
6	13	3/4.5	mm	06944
8	14	3.5/5	mm	09693
10	16	3.5/5	mm	15099
10	20	5/7	mm	U4175
10	20	5/8	mm	U3352
12	18	3.5/5	mm	22668
12	20	4/6	mm	U3193
12	22	5/8	mm	11134
12.7	18	3/4.5	mm	U5787
14	20	3.5/5	mm	14528
14	20	4/6	mm	11204
14	22	3/4	mm	U1821
15	21	3.5/5	mm	11974
15	21	4/5	mm	15032
15	25	5/7	mm	11579
16	22	3.5/5	mm	U7734
16	22	3/4	mm	21068
16	22	4/6	mm	U3194
16	24	3.5/5	mm	U1512
16	26	5/8	mm	U1820
18	24	4/6	mm	16888
18	28	5/7	mm	10375
18	28	7/10	mm	
19	30	5/8	mm	06485
20	28	3.5/5	mm	24364
20	28	7/10	mm	U2273
20	30	4/6	mm	24362
20	30	5/7	mm	14462
20	30	7/10	mm	21188
20	35	7/10	mm	16100
22	32	5/7	mm	
22	32	7/10	mm	06987
24	35	5/8	mm	09161
25	32	5/7	mm	U1693
25	33	4/7	mm	U4420
25	35	5/7	mm	

尺寸			單位	圖號
軸徑	孔徑	高度		
25	35	7/10	mm	
25.4	34	5/8	mm	20588
28	38	5/7	mm	15374
28	40	7/10	mm	U7386
28.57	52.38	9.52/12.70	mm	15377
30	40	5/7	mm	U2731
30	40	7/10	mm	40516
30	42	6/9	mm	
1.250	1.625	0.188/0.281	inch	
32	42	5/7	mm	17242
32	42	7/10	mm	U1418
32	45	4/7	mm	11482
32	45	7/10	mm	20356
1.375	2.250	0.375/0.500	inch	13677
35	45	5/7	mm	U2236
35	45	7/10	mm	11608
36	45	7/10	mm	13367
36	46	5/7	mm	11312
38	48	7/10	mm	12020
40	50	5/7	mm	
40	50	5/8	mm	
40	50	7/10	mm	06441
42	52	5/7	mm	09342
42	52	7/10	mm	16411
44	55	7/10	mm	08502
45	55	5/7	mm	15029
45	55	7/10	mm	
45	60	7/10	mm	08572
1.812	2.750	0.500/0.625	inch	18376
48	60	7/10	mm	09019
1.937	2.500	0.375/0.500	inch	19795
50	58	5/7	mm	11628
50	60	5/7	mm	13939
50	60	7/10	mm	03619
50	65	7/10	mm	16579
2.000	2.375	0.188/0.281	inch	15254









NAK 標準型式

# WP12

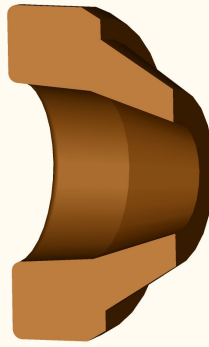

應用環境：防塵(WIPER)  
 材質：丁腈橡膠(NBR)  
 氟素橡膠(FKM)

尺寸			單位	圖號
軸徑	孔徑	高度		
12	18	3/5.3	mm	U7536
16	20	2.9/3.9	mm	U5700
16	22	3/5.3	mm	U7153
16	22	5/7	mm	U5768
17	25	3.9/7	mm	U7134
18	22	2.9/3.9	mm	U5576
18	24	3/5.3	mm	U7125
22	26	2.9/3.9	mm	U5577
22	30	5/7	mm	U4833
24	30	4.3/5.8	mm	U8255
24	32	5/7	mm	U7535
0.970	1.238	0.125/0.260	inch	U7903
25	33	5/7	mm	U5489
1.000	1.250	0.125/0.213	inch	U2019
27.95	35	3.5/5.3	mm	U0846
28	36	5/7	mm	U5221
29	35.5	2.6/4.5	mm	U1019
30	38	5/7	mm	U4832
33	40	3.5/5.3	mm	U2728
33	41	5/7	mm	U7168
34.5	40.65	2.5/3.8	mm	U1008
35	43	5/7	mm	U7159
36	44	5/7	mm	U5222
38	46	5/7	mm	U8239
40	46	4.3/5.8	mm	U5683
40	48	5/7	mm	U5781
40	50	7/9	mm	U4831
42	50	5/7	mm	U7154
42	54	6/9	mm	04238
44	52	3.9/7	mm	U7537
45	53	5/7	mm	U7149
45	53.5	5/8.5	mm	U7150
45	55	5/7	mm	U5223
50	58	5/7	mm	U5780
50	60	5/7	mm	U7169
51	59	3.9/7	mm	U7135

尺寸			單位	圖號
軸徑	孔徑	高度		
52	60	3.9/7	mm	U7152
53	61	5/7	mm	U7170
55	63	5/7	mm	U7171
55	65	5/7	mm	U7160
56	64	5/7	mm	U5224
56	66	5/7	mm	U5243
60	70	5/7	mm	U4830
63	71	5/7	mm	U5232
65	73	5/7	mm	U7161
65	75	5/7	mm	U4829
70	78	5/7	mm	U7162
70	80	5/7	mm	U5233
70	82	7/11.5	mm	U7166
73	81	5/7	mm	U7136
75	83	5/7	mm	U7528
75	87	7/12	mm	U7163
78	92	7/12	mm	U4825
80	88	5/7	mm	U7164
80	92	7/12	mm	U4826
85	97	7/12	mm	U4827
88	100	12/7	mm	U4828
90	98	5/7	mm	U5244
90	102	7/12	mm	U7155
93	101	3.9/7	mm	U7156
95	103	3.9/7	mm	U7529
95	107	7/12.5	mm	U7151
100	108	4/7	mm	U8230
100	112	7/12	mm	U7167
110	122	7/12	mm	U5235
115	127	7/12	mm	U7157
116	130	7/12	mm	U4859
125	137	7/12.5	mm	U7158
125	140	10/16	mm	U7138
130	142	7/12.5	mm	U7146
135	149	7/12	mm	U7147
140	152	7/12.5	mm	U7131

E4





















NAK 標準型式

# O-ring

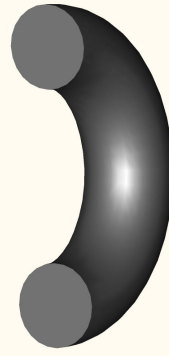

材質：丁腈橡膠(NBR)  
氟素橡膠(FKM)

尺寸		單位	圖號
內徑	線徑		
0.74	1.02	mm	R1001
0.9	0.95	mm	R0441
1.0	0.6	mm	
1	1	mm	R0101
1.07	1.27	mm	R1002
1.2	0.7	mm	R0261
1.25	2.62	mm	R1051
1.3	0.7	mm	R0260
1.4	0.6	mm	R0265
1.42	1.52	mm	R1003
1.5	1	mm	
1.5	1.5	mm	
1.78	1.78	mm	R1004
1.80	1.00	mm	R0723
1.8	1.4	mm	R0550
2	1	mm	
2	1.35	mm	
2	1.5	mm	
2.06	2.62	mm	R1052
2.1	1	mm	
2.2	1	mm	
2.2	1.6	mm	
2.5	0.5	mm	R0617
2.5	0.52	mm	
2.5	1.0	mm	
2.5	1.5	mm	
2.57	1.78	mm	R1005
2.7	1	mm	
2.7	1.6	mm	
2.75	1.6	mm	
2.8	0.9	mm	
2.8	1	mm	
2.8	1.4	mm	
2.8	1.6	mm	
2.8	1.9	mm	R2001
2.84	2.62	mm	R1053

尺寸		單位	圖號
內徑	線徑		
2.90	1.78	mm	R1006
3	0.5	mm	R0707
3	1	mm	R0686
3	1.5	mm	R0721
3	2	mm	
3.1	1.6	mm	
3.2	1.0	mm	R0266
3.2	1.5	mm	
3.22	1.016	mm	
3.3	1.02	mm	
3.3	1.5	mm	R0605
3.5	1	mm	R0334
3.5	1.1	mm	
3.5	1.5	mm	
3.5	1.78	mm	
3.63	2.62	mm	R1054
3.68	1.78	mm	R1007
3.7	1.1	mm	R0270
3.75	2.5	mm	
3.8	0.6	mm	
3.8	1.4	mm	R0625
3.8	1.5	mm	
3.8	1.9	mm	R2002
4	1	mm	R0525
4.0	1.2	mm	
4	1.5	mm	
4	2	mm	
4	3	mm	
4.00	144.60	mm	
4.1	1	mm	51276
4.1	1.3	mm	R0507
4.34	3.53	mm	R1128
4.42	2.62	mm	R1055
4.47	1.78	mm	R1008
4.5	1	mm	R0262
4.5	1.5	mm	R6001

E5



NAK 標準型式

# O-ring

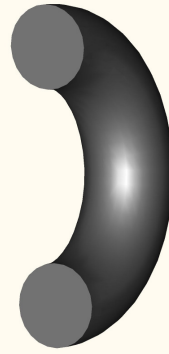
 材質：丁腈橡膠(NBR)  
 氟素橡膠(FKM)

E5

尺寸		單位	圖號
內徑	線徑		
4.5	1.8	mm	
4.5	2	mm	R0619
4.7	0.8	mm	
4.70	1.42	mm	R1358
4.7	2	mm	R0472
4.8	1.5	mm	
4.8	1.9	mm	R2003
5	1	mm	R0621
5	1.5	mm	
5	2	mm	
5	5	mm	
5.23	2.62	mm	R1056
5.28	1.78	mm	R1009
5.3	1	mm	
5.3	2.4	mm	R8053
5.33	0.08	mm	
5.5	1.3	mm	
5.5	1.4	mm	
5.5	1.5	mm	
5.5	2	mm	
0.220	0.063	inch	
5.63	2.24	mm	
5.8	1.9	mm	R2004
5.94	3.53	mm	R1129
6	1	mm	R0121
6	1.1	mm	
6	1.5	mm	
6	1.8	mm	
6	2	mm	
6	2.3	mm	R0510
6	2.62	mm	
6	3	mm	
6	5	mm	R0067
6.02	2.62	mm	R1057
6.07	1.63	mm	R1359
6.07	1.78	mm	R1010

尺寸		單位	圖號
內徑	線徑		
6.1	1.2	mm	
0.248	0.048	inch	
6.3	1.8	mm	R0476
6.3	2.4	mm	R0647
6.4	1.5	mm	
6.4	1.9	mm	
6.5	1	mm	
6.5	1.5	mm	
0.256	0.062	inch	R0672
6.7	1.8	mm	
6.7	2.1	mm	R0568
0.265	0.078	inch	
6.8	1.9	mm	R2005
6.8	2	mm	R0110
6.86	1.78	mm	
7	1	mm	
7	1.1	mm	
7	1.5	mm	
7	1.7	mm	R0197
7	2	mm	R0450
7	2.62	mm	
7.25	2.14	mm	R0041
7.3	2.2	mm	R0535
7.3	2.4	mm	R0493
7.5	0.8	mm	R0620
7.5	1	mm	
7.5	1.5	mm	R0079
7.5	2	mm	
7.5	2.1	mm	R0466
7.5	2.5	mm	
7.52	3.53	mm	R1130
0.299	0.103	inch	U3131
7.59	2.62	mm	R1058
7.6	2.4	mm	
7.65	1.63	mm	R1360
7.65	1.78	mm	R1011

NAK 標準型式

# O-ring

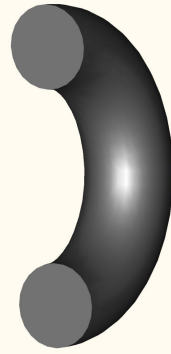
 材質：丁腈橡膠(NBR)  
 氟素橡膠(FKM)

尺寸		單位	圖號
內徑	線徑		
7.7	1.5	mm	
7.7	1.9	mm	R0656
7.7	2.3	mm	R0657
7.8	1.3	mm	R0320
7.8	1.8	mm	R0475
7.8	1.9	mm	R2006
7.8	2.4	mm	
7.8	3	mm	
7.8	3.5	mm	
8	1	mm	
8	1.1	mm	R0622
8	1.2	mm	R0477
8	1.3	mm	
8	1.5	mm	
8	2	mm	
8	2.5	mm	
8	3	mm	
8.1	1.6	mm	R0628
8.11	1.65	mm	R0139
8.3	2	mm	
8.3	2.4	mm	R0026
8.5	1.7	mm	
8.5	1.8	mm	
8.5	1.95	mm	R0513
8.5	2	mm	
8.73	1.78	mm	
8.8	1.9	mm	R2007
8.8	2.5	mm	
0.351	0.072	inch	
8.92	1.83	mm	R1361
9	1	mm	
9	1.4	mm	
9	1.5	mm	
9	1.6	mm	R0083
9	1.65	mm	
9	1.8	mm	

尺寸		單位	圖號
內徑	線徑		
9	1.92	mm	
9	2	mm	
9	3	mm	
9.12	3.53	mm	R1131
9.19	2.62	mm	R1059
9.2	1.8	mm	R0154
9.2	3	mm	
9.2	3.5	mm	R0333
9.5	1.5	mm	R1012
9.3	1.0	mm	
9.30	2.92	mm	
9.4	2.4	mm	R0090
9.4	2.5	mm	
9.4	3.53	mm	R0610
9.5	1.5	mm	R0078
9.5	2	mm	
9.5	2.4	mm	R0608
9.5	2.5	mm	
9.5	3.5	mm	
9.5	3.6	mm	R0368
9.6	1.5	mm	R0013
9.6	2.4	mm	
9.7	1.3	mm	R0136
9.8	1.9	mm	R2008
9.8	2.4	mm	R2009
9.92	2.62	mm	R0570
10	1	mm	R0639
10	1.4	mm	
10	1.5	mm	
10	1.6	mm	R0089
10	1.78	mm	R0439
10	2	mm	R0237
10	2.3	mm	
10	2.5	mm	
10	3	mm	R0520
10	4.5	mm	

E5

NAK 標準型式

# O-ring

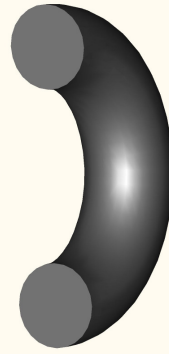

材質：丁腈橡膠(NBR)  
氟素橡膠(FKM)

E5

尺寸		單位	圖號
內徑	線徑		
10.1	1.1	mm	
10.16	1.57	mm	R0138
10.46	5.33	mm	R1212
10.5	1	mm	
10.5	1.5	mm	
10.5	2	mm	
10.5	2.7	mm	R0033
10.52	1.83	mm	R1362
10.6	3.5	mm	
10.69	3.53	mm	R1132
10.7	1.5	mm	
10.7	2.4	mm	R0473
10.77	2.62	mm	R1060
10.8	1	mm	
10.8	1.1	mm	
10.8	2.4	mm	R2010
10.82	1.78	mm	R1013
0.426	0.050	inch	R0068
0.426	0.070	inch	U3126
10.9	1.76	mm	R0561
11	1	mm	
11	1.5	mm	
11	1.9	mm	R0551
11	2	mm	
11	2.4	mm	R2011
11	2.50	mm	R0712
11	3	mm	
11	6.4	mm	
11.08	2.5	mm	R0364
11.1	2.5	mm	R0606
11.2	1.35	mm	R0778
11.25	1.78	mm	R0137
11.3	1.3	mm	R0085
11.3	2	mm	R0733
11.3	2.4	mm	R0649
11.5	1.5	mm	

尺寸		單位	圖號
內徑	線徑		
11.63	1.35	mm	R0032
11.79	2.4	mm	R0684
11.8	2.4	mm	R2012
11.83	2.3	mm	R0730
0.468	0.078	inch	R0772
11.89	1.98	mm	R1363
11.9	1.42	mm	
11.91	2.62	mm	R0498
12	1.0	mm	
12	1.45	mm	
12	1.5	mm	R0623
12	1.9	mm	
12	2	mm	R0058
12	2.5	mm	
12	3	mm	
0.473	0.079	inch	
12.07	5.33	mm	R1213
12.2	2	mm	
12.29	3.53	mm	R1133
12.3	1.6	mm	
12.3	2.16	mm	
12.3	2.4	mm	R2013
12.37	2.62	mm	R1061
12.4	1.8	mm	
12.42	1.78	mm	R1014
12.5	1.5	mm	
12.5	2	mm	
0.495	0.078	inch	
12.8	2.1	mm	
12.8	2.4	mm	R2135
12.85	2.7	mm	
0.506	0.078	inch	
12.9	1.9	mm	
12.9	2.5	mm	R0713
13	1	mm	
13	1.5	mm	

NAK 標準型式

# O-ring

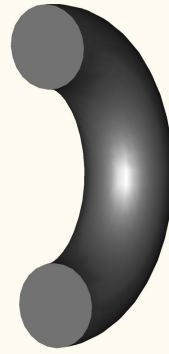
 材質：丁腈橡膠(NBR)  
 氟素橡膠(FKM)

尺寸		單位	圖號
內徑	線徑		
13	1.9	mm	
13	2	mm	R8303
13	2.2	mm	R8087
13	2.5	mm	R0221
13	2.8	mm	R0192
13	3	mm	R0655
13.1	1	mm	R0086
13.1	1.6	mm	R0500
13.2	1.3	mm	R0755
13.2	1.9	mm	R0715
0.525	0.078	inch	
13.46	2.08	mm	R1364
13.5	1.5	mm	
13.5	2	mm	
13.5	2.2	mm	
13.5	3	mm	
13.64	5.33	mm	R1214
13.7	1.36	mm	
13.7	1.5	mm	
13.8	1.3	mm	
13.8	1.9	mm	R0548
13.8	2.4	mm	R2014
13.8	2.5	mm	R0088
13.87	3.53	mm	R1134
13.9	1.78	mm	
13.94	2.62	mm	R1062
0.551	0.070	inch	
14	1	mm	
14	1.3	mm	
14	1.5	mm	R0765
14	1.78	mm	R1015
14	2	mm	R0502
14	2.5	mm	
14	3	mm	
14	4	mm	R0268
14.34	1.30	mm	

尺寸		單位	圖號
內徑	線徑		
14.5	1.5	mm	
14.5	2	mm	
14.5	2.62	mm	R0602
14.5	1.5	mm	
0.575	0.062	inch	
14.63	3.08	mm	
14.8	1.9	mm	
14.8	2.4	mm	
14.8	2.5	mm	R0549
14.9	2.3	mm	
15	1	mm	
15	1.5	mm	R0037
15	2	mm	R0009
15	2.5	mm	R0674
15	2.7	mm	
15	3	mm	
15.08	2.05	mm	R0680
15.08	2.62	mm	R0018
0.594	0.103	inch	
15.1	2.57	mm	
15.2	1.5	mm	R0194
15.2	1.8	mm	
15.2	2.5	mm	
15.24	5.33	mm	R1215
15.3	1.2	mm	U7757
15.3	1.5	mm	
15.3	2.2	mm	
15.3	2.4	mm	R0615
15.4	2.1	mm	
15.47	3.53	mm	R1135
15.5	1.5	mm	
15.5	2.4	mm	R0739
15.54	2.62	mm	R1063
0.614	0.070	inch	
15.60	1.78	mm	R1016
15.6	2.6	mm	

E5

NAK 標準型式

# O-ring

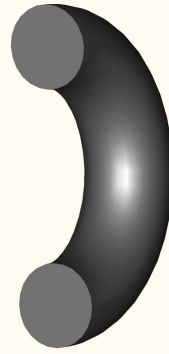
 材質：丁腈橡膠(NBR)  
 氟素橡膠(FKM)

E5

尺寸		單位	圖號
內徑	線徑		
15.75	1.8	mm	R0474
15.8	2.4	mm	R2016
15.82	2.4	mm	R0607
0.625	0.219	inch	R0066
16	1	mm	
16	1.5	mm	
16	1.7	mm	R0455
16	2	mm	R0017
16	2.4	mm	R0591
16	2.5	mm	
16	3	mm	
16.3	2.35	mm	
16.36	2.21	mm	R1365
16.5	3.9	mm	
16.6	1.95	mm	R0751
16.7	1.9	mm	
16.7	2	mm	
16.7	3.38	mm	R0556
16.7	3.5	mm	
16.8	1.5	mm	
16.8	2.4	mm	
16.81	5.33	mm	R1216
17	1	mm	
17	1.2	mm	
17	1.5	mm	
17	2	mm	R0015
17	2.5	mm	R0087
17	2.6	mm	
17	5.5	mm	
17.04	3.53	mm	R1136
17.12	2.62	mm	R1064
17.17	1.78	mm	R1017
17.17	2.62	mm	R0546
17.5	1.5	mm	R0776
17.5	2.5	mm	
17.5	2.85	mm	R0536

尺寸		單位	圖號
內徑	線徑		
17.6	1.26	mm	
17.8	2.4	mm	R2017
17.93	2.46	mm	R1366
18	1	mm	
18	1.5	mm	
18	1.7	mm	
18	2	mm	
18	2.5	mm	44015
18	3	mm	R0106
18	3.5	mm	R0098
18.2	1	mm	
18.3	3.6	mm	R0027
18.4	1.8	mm	R0746
18.42	5.33	mm	R1217
18.64	3.53	mm	
18.66	3.53	mm	R1137
18.72	2.62	mm	R1065
18.77	1.78	mm	R1018
18.8	2.4	mm	R2137
18.8	2.6	mm	
19	1.5	mm	
19	2	mm	R0650
19	2.5	mm	
19	3	mm	
19	3.5	mm	
19.18	2.46	mm	R1367
19.2	2.5	mm	
19.4	3.1	mm	
19.5	1.3	mm	
19.5	1.5	mm	
19.5	1.75	mm	R0456
19.5	2	mm	
19.7	1.6	mm	
19.71	2.54	mm	24149
19.8	1.3	mm	
19.8	2.4	mm	R2018

NAK 標準型式

# O-ring

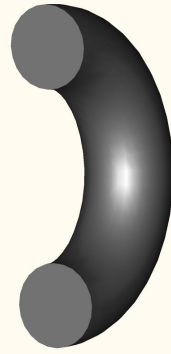

材質：丁腈橡膠(NBR)  
氟素橡膠(FKM)

尺寸		單位	圖號
內徑	線徑		
19.99	5.33	mm	R1218
20	1	mm	
20	1.5	mm	
20	1.78	mm	
20	1.9	mm	R0614
20	2	mm	R0396
20	2.5	mm	R0097
20	2.8	mm	R0696
20	3	mm	
20.0	3.0	mm	
20	3.5	mm	R0443
20	4	mm	
20	4.5	mm	
20.22	3.53	mm	R1138
20.29	2.62	mm	R1066
20.3	1.3	mm	
20.3	1.5	mm	
20.3	2.62	mm	
20.35	1.78	mm	R1019
20.5	1	mm	
20.5	3	mm	
20.6	1.80	mm	R0737
20.6	2.8	mm	
20.7	1.51	mm	
20.8	1.5	mm	
20.8	2.4	mm	R2019
21	1	mm	
21	1.5	mm	
21	2	mm	
21	2.5	mm	
21	3	mm	
21	3.53	mm	
21.2	1.2	mm	
21.2	2.4	mm	R0659
21.2	2.5	mm	R0754
21.2	3	mm	R0766

尺寸		單位	圖號
內徑	線徑		
21.25	3.35	mm	
21.5	1.5	mm	
21.5	2.0	mm	
21.59	5.33	mm	R1219
21.6	1.15	mm	
21.7	3	mm	
21.7	3.5	mm	R2021
21.8	2.4	mm	R2020
21.82	3.53	mm	R1139
21.89	2.62	mm	
21.9	2.41	mm	
21.90	2.62	mm	R1067
21.92	2.95	mm	R1368
0.864	0.070	inch	R0062
21.95	1.78	mm	R1020
22	1.5	mm	
22	2	mm	R0244
22	2.5	mm	
22	3	mm	
22	3.5	mm	
22	4	mm	
22	5	mm	
22.1	3.5	mm	R2022
22.8	1.9	mm	R0445
0.900	0.062	inch	
22.9	2	mm	
23	1.0	mm	
23	1.5	mm	
23	1.8	mm	R0742
23	2	mm	
23	2.5	mm	
23	3	mm	
23	3.5	mm	R0467
23	3.53	mm	
23	4.5	mm	
23.16	5.33	mm	R1220

E5



NAK 標準型式

# O-ring

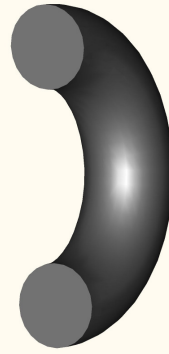
 材質：丁腈橡膠(NBR)  
 氟素橡膠(FKM)

E5

尺寸		單位	圖號
內徑	線徑		
23.4	1.9	mm	
23.47	2.62	mm	R1068
23.47	2.95	mm	R1369
23.5	2	mm	
23.5	2.1	mm	R0660
23.52	1.78	mm	R1021
23.6	1.90	mm	
23.7	2.4	mm	R0745
23.7	3.5	mm	R2023
24	1.5	mm	
24	2	mm	
24	2.2	mm	R0437
24	2.4	mm	R0747
24	3	mm	
24	3.1	mm	
24.4	3.1	mm	R3001
24.5	2	mm	
24.7	0.8	mm	R0145
24.7	2.6	mm	
24.7	3	mm	
24.7	3.5	mm	R2024
24.77	5.33	mm	R1221
24.8	1.5	mm	
24.99	3.53	mm	R1141
25	1.5	mm	
25	1.6	mm	
25	2	mm	
25	2.4	mm	R0107
25	2.5	mm	
25	2.62	mm	
25	3	mm	R0499
25	3.5	mm	R0259
25	4	mm	
25	4.5	mm	
25	5	mm	
25	5.5	mm	R0486

尺寸		單位	圖號
內徑	線徑		
25.04	2.95	mm	R1370
25.07	2.62	mm	R1069
25.1	2.30	mm	R0752
25.1	3.1	mm	R0392
24.9	1.7	mm	R0397
25.2	3.5	mm	R2025
25.4	2	mm	
25.2	20	mm	R6011
25.5	1.5	mm	
25.5	1.78	mm	
25.5	4	mm	
25.6	3.3	mm	
25.7	3.5	mm	R2026
25.8	2.4	mm	
25.8	3	mm	
25.8	3.53	mm	
26	1	mm	
26	1.5	mm	
26	2	mm	
26	2.2	mm	R0438
26	2.5	mm	
26	3	mm	
26.34	5.33	mm	R1222
26.58	3.53	mm	R1142
26.59	2.95	mm	R1371
26.59	3	mm	
26.65	2.62	mm	R1070
26.70	1.78	mm	R1023
26.7	3.4	mm	
27	1.5	mm	
27	2	mm	R0080
27	2.5	mm	
27	2.62	mm	U1369
27	3	mm	
27	3.5	mm	R0588
27	4	mm	

NAK 標準型式

# O-ring

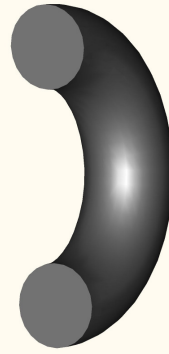

材質：丁腈橡膠(NBR)  
氟素橡膠(FKM)

尺寸		單位	圖號
內徑	線徑		
27	4.5	mm	
27	5	mm	
27	6	mm	
27.1	2.4	mm	R0748
27.4	2.4	mm	R0096
27.5	2	mm	
27.5	2.1	mm	R0725
27.6	1.9	mm	R0053
27.7	3.45	mm	R0366
27.7	3.5	mm	R2027
27.72	3.27	mm	
27.75	3.15	mm	R0365
27.94	5.33	mm	R1223
28	1	mm	
28	1.9	mm	
28	2	mm	
28	2.5	mm	
28	3	mm	
28	4	mm	
28.17	3.53	mm	R1143
28.24	2.62	mm	
28.25	2.62	mm	R1071
28.30	1.78	mm	R1024
28.5	2	mm	
28.6	3.1	mm	
28.7	3.5	mm	R2028
28.9	3.1	mm	
1.140	0.125	inch	
29	2	mm	
29	2.5	mm	
29.1	1	mm	R0100
29.2	3.5	mm	R2029
1.156	0.297	inch	R0005
29.4	3.1	mm	
29.5	1.5	mm	
29.5	2.0	mm	R6002

尺寸		單位	圖號
內徑	線徑		
29.51	5.33	mm	R1224
29.7	3.5	mm	R2030
29.74	2.95	mm	R1373
29.74	3.53	mm	R1144
29.8	2.5	mm	
29.82	2.62	mm	R1072
1.176	0.07	inch	U3127
29.87	1.78	mm	R1025
30	1.5	mm	
30	2	mm	
30	2.5	mm	
30	3	mm	
30	3.5	mm	
30	4	mm	R0703
30	4.5	mm	
30	5	mm	
30.2	3.2	mm	
1.200	0.123	inch	
30.5	2.6	mm	R0029
30.5	3	mm	
30.7	3.5	mm	R2031
30.8	3.2	mm	R0081
1.219	0.094	inch	
31	1.5	mm	
31	1.7	mm	R0661
31	1.75	mm	
31	2	mm	
31	2.7	mm	R0662
31	3	mm	
31	4	mm	
31	4.7	mm	
31.12	5.33	mm	R1225
31.19	1.87	mm	
31.2	1.5	mm	
31.2	3.5	mm	R2032
31.2	4.1	mm	

E5

NAK 標準型式

# O-ring

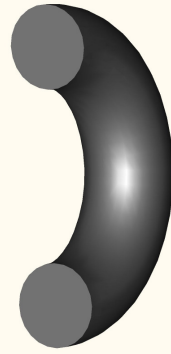

材質：丁腈橡膠(NBR)  
氟素橡膠(FKM)

E5

尺寸		單位	圖號
內徑	線徑		
31.35	3.53	mm	R1145
31.42	2.62	mm	R1073
31.47	1.78	mm	R1026
31.5	2	mm	R6009
31.5	3	mm	
31.6	1	mm	
31.7	3.5	mm	R2033
31.75	2.38	mm	R0491
31.8	36	3 mm	A1034
31.85	2	mm	R0398
32	1	mm	
32	1.5	mm	
32	1.8	mm	R0611
32	1.9	mm	R0663
32	2	mm	
32	2.5	mm	
32	3	mm	
32	3.5	mm	
32	3.70	mm	
32	4	mm	
32	5	mm	
32.5	2.5	mm	
32.69	5.33	mm	R1226
32.7	2	mm	
32.92	3.53	mm	R1146
32.99	2.62	mm	R1074
32.99	2.62	mm	
1.299	0.103	inch	U3133
33	1.5	mm	
33	1.9	mm	R0664
33	2	mm	
33	2.5	mm	
33	2.62	mm	R1074
33	3	mm	
33	3.5	mm	
33	4.5	mm	

尺寸		單位	圖號
內徑	線徑		
33.05	1.78	mm	R1027
33.1	2.2	mm	R0558
33.3	2.4	mm	
33.5	1.5	mm	
33.5	2	mm	
33.5	3	mm	R0199
33.5	3.7	mm	R0564
33.7	1.9	mm	
33.7	3.5	mm	R2034
33.8	2.7	mm	
34	1.9	mm	R0665
34	2	mm	
34	3	mm	
34	3.5	mm	R0530
34	4	mm	
34.1	3.6	mm	
34.29	5.33	mm	R1227
34.4	3.1	mm	R3003
34.42	2.95	mm	R1374
34.5	1.2	mm	
34.5	2	mm	R6008
34.5	2.5	mm	
34.52	3.5	mm	
34.52	3.53	mm	R1147
34.59	2.62	mm	R1075
34.60	2.62	mm	R1075
1.364	0.07	inch	U3128
34.65	1.78	mm	R1028
34.7	3.5	mm	R2035
35	1.5	mm	
35	2	mm	A0391
35	2.5	mm	
35	3	mm	R0095
35	4	mm	
35	4.5	mm	
35	5	mm	

NAK 標準型式

# O-ring

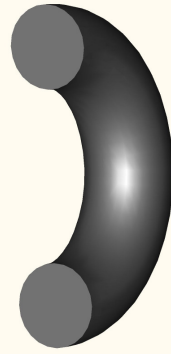
 材質：丁腈橡膠(NBR)  
 氟素橡膠(FKM)

尺寸		單位	圖號
內徑	線徑		
35	7	mm	
35.2	3.5	mm	R2036
35.4	3.1	mm	R0363
35.5	1.0	mm	R0547
35.5	2	mm	
35.7	3.5	mm	R2037
36	1.5	mm	
36	2	mm	
36	3	mm	
36	4	mm	
36	5	mm	R0705
36	5.2	mm	R0335
36.09	3.53	mm	R1148
36.17	2.62	mm	R1076
36.5	2	mm	R0590
36.5	3.0	mm	R0727
36.7	1.9	mm	
37	1	mm	
37	1.5	mm	
37	2	mm	
37	2.5	mm	
37	3	mm	
37	3.5	mm	
37	4	mm	
37	4.2	mm	
37	4.5	mm	
37.1	1.6	mm	R0658
37.47	3.00	mm	R1375
37.47	5.33	mm	R1228
37.5	2.0	mm	
37.5	42	3 mm	A1032
37.69	3.5	mm	R0578
37.69	3.53	mm	R1149
37.7	3.5	mm	R2038
37.77	2.62	mm	R1077
37.82	1.78	mm	R1029

尺寸		單位	圖號
內徑	線徑		
1.489	0.070	inch	U3129
38	1.5	mm	
38	2	mm	R0211
38	3	mm	
38	3.5	mm	
38	4	mm	
38	6	mm	
38.1	1.8	mm	R0054
38.5	2	mm	
38.7	3.5	mm	R2039
38.8	1.9	mm	
39	1.5	mm	
39	3.0	mm	
39	3.5	mm	R0336
39	4	mm	
1.549	0.103	mm	U3134
39.35	2.62	mm	R1078
39.4	3.1	mm	R3004
39.5	1	mm	R0063
39.5	2	mm	
39.7	2.4	mm	R0749
39.7	3.5	mm	R2040
39.8	2.2	mm	R0666
40	1.5	mm	
40	1.9	mm	R0667
40	2	mm	
40	2.5	mm	
40	3	mm	
40	3.5	mm	
40	4	mm	
40	4.5	mm	
40	5	mm	
40	8	mm	
40.08	2.64	mm	R0494
40.2	3	mm	R0238
40.64	5.33	mm	R1229

E5

NAK 標準型式

# O-ring

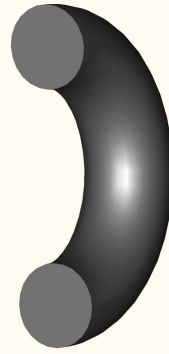
 材質：丁腈橡膠(NBR)  
 氟素橡膠(FKM)

E5

尺寸		單位	圖號	
內徑	線徑			
40.64	6.99	mm	R0681	
40.7	1.5	mm		
40.7	3.5	mm	R2041	
40.87	3.53	mm	R1150	
40.95	2.62	mm	R1079	
41	1.78	mm	R1030	
41	2	mm		
41	3	mm		
41	4	mm		
41	5	mm	R0706	
41	5.5	mm	R0449	
41.2	3.5	mm		
41.5	2	mm	R0332	
41.7	2.5	mm	R0183	
41.7	3.5	mm	R2042	
42	1	mm		
42	1.5	mm		
42	2	mm		
42	2.4	mm		
42	2.5	mm		
42	3	mm	R0239	
42	4	mm		
42.2	2.4	mm		
42.2	3	mm	R0653	
42.2	45.5	1.65	mm	A0348
42.3	3	mm		
42.5	3	mm		
42.52	2.62	mm	R1080	
42.7	1	mm	R0321	
43	1.5	mm		
43	2	mm		
43	2.5	mm		
43	3	mm		
43	3.5	mm		
43	4.5	mm		
43	5	mm		

尺寸		單位	圖號
內徑	線徑		
1.713	0.078	inch	
43.69	3.00	mm	R1376
43.7	3.5	mm	R2043
43.82	5.33	mm	R1230
44	2	mm	R0691
44	4	mm	
44.04	3.53	mm	R1151
44.12	2.62	mm	R1081
1.739	0.07	mm	U3130
44.17	1.78	mm	R1031
44.2	2.3	mm	R0744
44.2	3	mm	R0654
44.2	5.7	mm	
44.3	1.4	mm	
44.4	3.1	mm	R3005
44.5	1.85	mm	
44.5	2	mm	
44.6	1.9	mm	R0056
44.7	2.4	mm	R0554
44.7	3.5	mm	R2044
45	1.5	mm	
45	1.9	mm	
45	2	mm	
45	2.5	mm	
45	2.7	mm	
45	3	mm	
45	3.5	mm	
45	4	mm	
45	4.5	mm	
45	5	mm	
45	8	mm	
45.2	1.5	mm	
45.3	5.7	mm	
45.5	2	mm	
45.7	2.62	mm	R1082
45.7	3.5	mm	R2045

NAK 標準型式

# O-ring

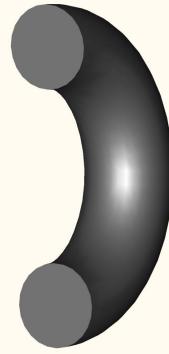
 材質：丁腈橡膠(NBR)  
 氟素橡膠(FKM)

尺寸		單位	圖號
內徑	線徑		
46	1.5	mm	
46	2	mm	
46.5	1.50	mm	
46.5	1.77	mm	
46.5	2	mm	
46.5	2.5	mm	
46.8	1.5	mm	
46.8	2.2	mm	R0668
46.99	5.33	mm	R1231
47	1.5	mm	
47	2	mm	
47	2.5	mm	R0182
47	3	mm	
47	4.5	mm	
47	5	mm	
47	6.4	mm	R0542
47.22	3.53	mm	R1152
47.29	2.62	mm	R1083
47.35	1.78	mm	R1032
47.5	2	mm	
47.6	5.7	mm	R2047
47.7	3.5	mm	R2046
48	1.5	mm	R0627
48	2	mm	
48	2.25	mm	R0634
48	4	mm	R0704
48	6	mm	R0324
48.5	2.0	mm	R0544
48.6	3.1	mm	
48.7	3.5	mm	R2048
48.8	5	mm	
48.90	2.62	mm	R1084
49	1.77	mm	R0454
49	2	mm	
49	3.53	mm	
49.2	5.7	mm	

尺寸		單位	圖號
內徑	線徑		
49.4	1.0	mm	R0038
49.4	3.1	mm	R3006
49.5	2	mm	
49.5	2.5	mm	
49.6	5.7	mm	R2050
49.7	3.5	mm	R2049
49.8	1.5	mm	
1.962	0.079	inch	
50	1.5	mm	
50	2	mm	R0543
50	2.5	mm	
50	3	mm	
50	3.5	mm	
50	4	mm	
50	4.5	mm	
50	5	mm	
50	8	mm	
50.17	5.33	mm	R1232
50.39	3.53	mm	R1153
50.47	2.62	mm	R1085
50.52	1.78	mm	R1033
50.9	2.45	mm	R0562
51.5	1.5	mm	
51.6	5.7	mm	R2051
51.62	3.13	mm	
51.8	1.5	mm	
51.82	1.5	mm	
52	2	mm	
52	3	mm	R0774
52	4	mm	
52	5	mm	
52.07	2.62	mm	R1086
52.2	2	mm	R0638
52.6	5.7	mm	R2052
53	2	mm	
53	3	mm	

E5



NAK 標準型式

# O-ring

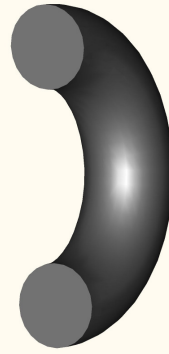
 材質：丁腈橡膠(NBR)  
 氟素橡膠(FKM)

E5

尺寸		單位	圖號
內徑	線徑		
53	3.5	mm	
53	5	mm	
53.09	3.00	mm	R1377
53.3	1.78	mm	R0714
53.34	5.33	mm	R1233
53.5	2.0	mm	R6004
53.57	3.53	mm	R1154
53.64	2.62	mm	R1087
53.7	1.78	mm	R1034
53.97	1.78	mm	R0384
2.125	0.125	inch	
54	2	mm	
54.2	3	mm	
54.4	3.1	mm	R3007
54.5	1.5	mm	
54.5	1.8	mm	
54.5	2	mm	R0331
54.6	5.7	mm	R2054
55	1	mm	
55	2	mm	
55	2.5	mm	
55	3	mm	
55	3.5	mm	
55	4	mm	
55	5	mm	
55	6	mm	
2.175	0.070	inch	R0226
55.25	2.62	mm	R1088
55.4	3.1	mm	R3047
55.5	2	mm	
55.6	5.7	mm	R2055
56	3.5	mm	
56	8	mm	
56.52	5.33	mm	R1234
56.74	3.53	mm	R1155
56.8	3.0	mm	

尺寸		單位	圖號
內徑	線徑		
2.237	0.103	inch	U0111
56.82	2.62	mm	R1089
56.87	1.78	mm	R1035
57	1.5	mm	
57	2	mm	
57	2.5	mm	
57	3	mm	
57	4	mm	
57	5	mm	
57.2	2.8	mm	R0731
57.4	3.1	mm	
57.4	7	mm	R0717
57.6	5.7	mm	R2056
58	1.5	mm	
58	1.78	mm	R0716
58	3	mm	R0769
58	5	mm	
58.42	2.62	mm	R1090
58.92	3.14	mm	
59	3.5	mm	R0468
59.36	3.00	mm	R1378
59.4	3.1	mm	R3008
59.5	1.9	mm	R0055
59.5	2.0	mm	
59.6	5.7	mm	R2057
59.69	5.33	mm	R1235
59.92	3.53	mm	R1156
59.99	2.62	mm	R1091
60	1.5	mm	
60	1.9	mm	
60	2	mm	
60	2.40	mm	
60	2.5	mm	
60	3	mm	
60	3.5	mm	
60	4	mm	

NAK 標準型式

# O-ring

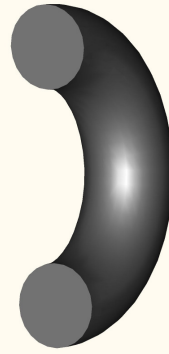
 材質：丁腈橡膠(NBR)  
 氟素橡膠(FKM)

尺寸		單位	圖號
內徑	線徑		
60	4.5	mm	
60	4.6	mm	R8138
60	5	mm	
60	7	mm	
60.05	1.78	mm	R1036
60.5	3.0	mm	
61	1.5	mm	R0060
61	2.5	mm	R0240
61.3	3.1	mm	
61.60	2.62	mm	R1092
61.6	5.7	mm	R2058
61.7	1.78	mm	
62	1.5	mm	
62	2	mm	
62	2.5	mm	
62	3	mm	R0702
62	4	mm	
62	5	mm	
62	5.3	mm	
62.3	1.2	mm	R0040
62.5	2.0	mm	
62.5	2.3	mm	
62.5	3.5	mm	R0604
62.6	5.7	mm	R2059
62.8	2.7	mm	
62.87	5.33	mm	R1236
63	2	mm	
63	3.5	mm	
63	4	mm	R0612
63.09	3.53	mm	R1157
63.17	2.62	mm	R1093
63.22	1.78	mm	R1037
63.4	2	mm	
63.5	3	mm	R0378
63.5	6.35	mm	
63.8	3.0	mm	R0603

尺寸		單位	圖號
內徑	線徑		
64	2.3	mm	R0563
64	4	mm	
64.2	2.6	mm	R0758
64.4	3.1	mm	R3009
64.5	2	mm	
64.6	5.7	mm	R2060
64.77	2.62	mm	R1094
65	2	mm	
65	2.5	mm	
65	3	mm	R0499
65	3.5	mm	
65	4	mm	
65	4.5	mm	
65	5	mm	
65.5	1.5	mm	
65.6	2.4	mm	
66	2	mm	R0762
66	2.46	mm	R0099
66	2.5	mm	
66	3	mm	
66	4	mm	
66.04	5.33	mm	R1237
66.27	3.53	mm	R1158
66.34	2.62	mm	R1095
2.614	0.070	inch	U3593
66.40	1.78	mm	R1038
66.6	5.7	mm	R2061
67	1.5	mm	
67	2	mm	
67	2.5	mm	
67	3	mm	
67	3.5	mm	
67	4	mm	
67	8	mm	
67.5	6.3	mm	
67.6	2.4	mm	

E5

NAK 標準型式

# O-ring

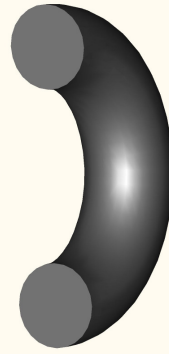

材質：丁腈橡膠(NBR)  
氟素橡膠(FKM)

E5

尺寸		單位	圖號
內徑	線徑		
67.95	2.62	mm	R1096
68	3.57	mm	
68	8	mm	R0613
68.45	2.83	mm	
69	4	mm	
69.2	5.7	mm	R0641
69.22	5.33	mm	R1238
69.4	3.1	mm	R3010
69.44	3.53	mm	R1159
69.5	2	mm	
69.52	2.62	mm	R1097
69.57	1.78	mm	R1039
69.6	5.7	mm	R2062
70	1.5	mm	
70	2	mm	
70	2.5	mm	
70	3	mm	
70	3.5	mm	
70	4	mm	
70	4.5	mm	
70	5	mm	
70.4	2.4	mm	
70.6	5.7	mm	R2063
70.7	2	mm	R0051
71.12	2.62	mm	R1098
71.3	2	mm	R0419
71.5	2.4	mm	R0741
71.7	2.5	mm	
71.8	3.1	mm	
72	2	mm	
72.39	5.33	mm	R1239
72.5	3.1	mm	
72.62	3.53	mm	R1160
72.69	2.62	mm	U7188
72.70	2.62	mm	R1099
72.75	1.78	mm	R1040

尺寸		單位	圖號
內徑	線徑		
73	2.5	mm	
73	3	mm	
73	3.5	mm	
73	4	mm	R0609
73	5	mm	
73.91	3.53	mm	R0517
74	1	mm	
74	1.78	mm	R0771
74	3	mm	
2.924	0.103	inch	
74.4	3.1	mm	R3011
74.5	2	mm	R6007
74.5	3.55	mm	R0728
74.6	5.7	mm	R2064
75	2	mm	R0760
75	2.5	mm	
75	3	mm	
75	3.5	mm	
75	4	mm	
75	5	mm	
75	6	mm	
75.57	5.33	mm	R1240
75.79	3.53	mm	R1161
75.87	2.62	mm	R1100
75.92	1.78	mm	R1041
76	4	mm	
76.3	4.3	mm	
77	1.5	mm	
77	2.35	mm	
77.1	1.25	mm	R0526
77.6	5.7	mm	
78	2.5	mm	
78.74	5.33	mm	R1241
78.9	1.8	mm	R0757
78.97	3.53	mm	R1162
79	2	mm	

NAK 標準型式

# O-ring

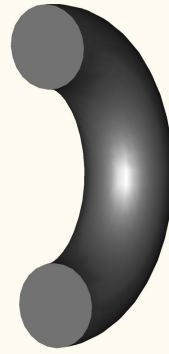
 材質：丁腈橡膠(NBR)  
 氟素橡膠(FKM)

尺寸		單位	圖號
內徑	線徑		
79.2	1.2	mm	R0034
79.4	3.1	mm	R3012
79.5	2	mm	R6006
79.6	5.7	mm	R2065
80	2	mm	
80	2.4	mm	R0726
80	2.5	mm	U7187
80	3	mm	
80	3.5	mm	
80	4	mm	
80	5	mm	
80	6	mm	
80	8	mm	R0555
80.4	1.5	mm	
81	2.4	mm	R0779
81.92	3.5	mm	
81.92	5.33	mm	R1242
82	3	mm	
82.14	3.53	mm	R1163
82.22	2.62	mm	R1101
82.27	1.78	mm	R1042
82.5	2.5	mm	
83	2.4	mm	R0729
83	3	mm	R0210
83	3.5	mm	
83.35	2.50	mm	R0740
83.5	3	mm	R0465
84	2.5	mm	R0750
84	3.5	mm	
84	4	mm	R0682
84.1	5.7	mm	R0642
84.4	3.1	mm	R3013
84.5	2	mm	
84.5	2.1	mm	R0052
84.5	2.45	mm	R0675
84.5	2.5	mm	R0646

尺寸		單位	圖號
內徑	線徑		
84.5	3.1	mm	
84.6	5.7	mm	R2066
85	2	mm	
85	2.1	mm	
85	2.5	mm	
85	3	mm	
85.0	3.58	mm	
85	4	mm	
85	5	mm	
85.09	5.33	mm	R1243
85.32	3.53	mm	R1164
85.8	1.25	mm	R0640
86	2.5	mm	U0770
86	3	mm	
87	3	mm	R0767
87	5	mm	
87.6	2.59	mm	R0709
87.65	3.2/3.9	mm	R0325
88	3	mm	
88	4	mm	
88.27	5.33	mm	R1244
88.49	3.53	mm	R1165
88.5	2	mm	R0697
88.57	2.62	mm	R1102
88.62	1.78	mm	R1043
88.85	3.25	mm	R0322
89.1	1.9	mm	
89.1	5.7	mm	R0643
89.4	3.1	mm	R3014
89.50	2	mm	
89.6	5.7	mm	R2067
90	2	mm	
90	2.5	mm	
90	4	mm	
90	4.5	mm	
90	5	mm	

E5

NAK 標準型式

# O-ring

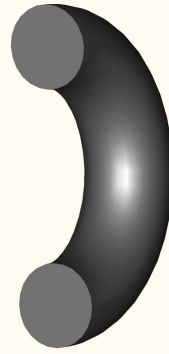
 材質：丁腈橡膠(NBR)  
 氟素橡膠(FKM)

E5

尺寸		單位	圖號
內徑	線徑		
91	3.15	mm	
91	5	mm	R0469
91.44	5.33	mm	R1245
91.5	3	mm	R0645
91.67	3.53	mm	R1166
91.69	1.78	mm	R0552
92	3.1	mm	
93	3	mm	
93.4	4	mm	
94	2.2	mm	R0669
94	3	mm	R0200
94	3.55	mm	
94	4	mm	
94.1	5.7	mm	
94.4	3.1	mm	R3015
94.5	2	mm	
94.5	2.5	mm	
94.6	5.7	mm	R2068
94.62	5.33	mm	R1246
94.7	3	mm	R0559
94.8	2.93	mm	
94.84	3.53	mm	R1167
94.92	2.62	mm	R1103
94.97	1.78	mm	R1044
94.97	2.04	mm	
95	2	mm	
95	2.4	mm	
95	3	mm	
95	3.5	mm	
95	4	mm	
95	4.5	mm	
95	5	mm	
95	6	mm	
96.2	6	mm	
96.6	4	mm	R0327
97	5	mm	

尺寸		單位	圖號
內徑	線徑		
97.79	5.33	mm	R1247
98.02	3.53	mm	R1168
98.1	3.1	mm	
99	1.2	mm	R0061
99	2	mm	R0111
99	3	mm	R0204
99.1	5.7	mm	
99.4	3.1	mm	R3016
99.5	2	mm	
99.6	5.7	mm	R2069
100	2	mm	
100	3	mm	
100	3.5	mm	
100	4	mm	
100	5	mm	
100	6	mm	
100.34	5.33	mm	R0557
100.6	5.7	mm	R0567
100.97	5.33	mm	R1248
101.19	3.53	mm	R1169
101.2	3.1	mm	R0678
101.27	2.62	mm	R1104
101.32	1.78	mm	R1045
101.6	5.7	mm	R2070
102	3	mm	
103	3.5	mm	
103	6	mm	
104	3.1	mm	
104	4.6	mm	
104.1	5.7	mm	R0652
104.14	5.33	mm	R1249
104.3	6	mm	R0464
104.37	3.53	mm	R1170
104.4	3.1	mm	R3017
104.6	5.7	mm	R2071
105	2.4	mm	R0692

NAK 標準型式

# O-ring

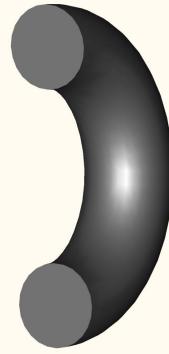

材質：丁腈橡膠(NBR)  
氟素橡膠(FKM)

尺寸		單位	圖號
內徑	線徑		
105	2.6	mm	R0306
105	3	mm	
105	3.5	mm	
105	4	mm	
105	5	mm	
105	5.5	mm	R0598
105	6	mm	
105	112	3.9 mm	R0065
106	2	mm	
107	2.0	mm	R0108
107	4.7	mm	A0451
107	5	mm	
107.32	5.33	mm	R1250
107.54	3.53	mm	R1171
107.62	2.62	mm	R1105
107.67	1.78	mm	R1046
107.7	3.17	mm	R0676
108	2.0	mm	
108	4	mm	
109	5	mm	
109.4	3.1	mm	R3018
109.5	2	mm	
109.6	5.7	mm	R2072
110	2	mm	
110	2.2	mm	R0670
110	3	mm	
110	3.5	mm	
110	4	mm	R0326
110	4.5	mm	
110	5	mm	U0769
110	6	mm	
110.49	5.33	mm	R1251
110.72	3.53	mm	R1172
111.6	5.7	mm	R2073
112	3	mm	
112	5	mm	

尺寸		單位	圖號
內徑	線徑		
112.26	3.55	mm	
112.3	3.43	mm	R0685
113.5	2.52	mm	R0700
113.67	5.33	mm	R1252
113.67	6.99	mm	R1299
113.89	3.53	mm	R1173
113.97	2.62	mm	R1106
114	2.2	mm	R0671
114	6	mm	
114.02	1.78	mm	R1047
114.3	5.7	mm	R0644
114.4	3.1	mm	R3019
114.5	2	mm	
114.6	5.7	mm	R2074
115	3	mm	
115	4	mm	
115	4.5	mm	
115	5	mm	
115.5	3	mm	R0701
115.5	3.5	mm	
116	4	mm	
116.4	3.175	mm	
116.5	2	mm	
116.84	5.33	mm	R1253
116.84	6.99	mm	R1300
117	4	mm	
117.07	3.53	mm	R1174
118	4.5	mm	
118	6	mm	
119.4	3.1	mm	R3020
119.5	2	mm	R6012
119.6	5.7	mm	R2075
120	2	mm	
120	3	mm	
120	4	mm	
120	4.5	mm	

E5



NAK 標準型式

# O-ring

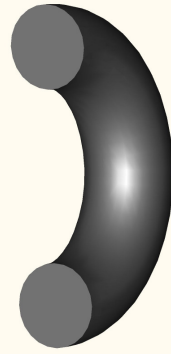
 材質：丁腈橡膠(NBR)  
 氟素橡膠(FKM)

E5

尺寸		單位	圖號
內徑	線徑		
120	5	mm	
120	6	mm	
120.02	5.33	mm	R1254
120.02	6.99	mm	R1301
120.24	3.53	mm	R1175
120.32	2.62	mm	R1107
120.37	1.78	mm	R1048
121.5	2	mm	R0677
122	3	mm	
122	5	mm	R0471
122.5	4.8	mm	
122.76	1.95	mm	R0504
122.8	2	mm	R0693
123.19	5.33	mm	R1255
123.19	6.99	mm	R1302
123.42	3.53	mm	R1176
124.14	2.01	mm	R0695
124.4	3.1	mm	R3021
124.5	2	mm	
124.6	2.4	mm	
124.6	5.7	mm	R2076
125	2	mm	
125	3	mm	
125	4	mm	
125	6	mm	
126	4.5	mm	
126.37	5.33	mm	R1256
126.37	6.99	mm	R1303
126.59	3.53	mm	R1177
126.67	2.62	mm	R1108
126.72	1.78	mm	R1049
127	3.5	mm	
127	4	mm	
128.7	3.5	mm	
129.29	5.81	mm	
129.3	5.7	mm	

尺寸		單位	圖號
內徑	線徑		
129.4	3.1	mm	R3022
129.5	2	mm	
129.54	5.33	mm	R1257
129.54	6.99	mm	R1304
129.6	5.7	mm	R2077
129.77	3.53	mm	R1178
130	2	mm	
130	3.5	mm	
130	4	mm	
130	4.5	mm	
130	6	mm	
131	3.5	mm	
131.6	5.7	mm	R2078
131.8	3.2	mm	R0560
132	3.1	mm	
132.72	5.33	mm	R1258
132.72	6.99	mm	R1305
132.94	3.53	mm	R1179
133	4	mm	
133.02	2.62	mm	R1109
133.07	1.78	mm	R1050
134.3	5.7	mm	
134.4	3.1	mm	R3023
134.5	2	mm	
134.5	3	mm	
134.6	5.7	mm	R2079
135	4	mm	
135	6	mm	
135.89	5.33	mm	R1259
135.89	6.99	mm	R1306
136.12	3.53	mm	R1180
137	4	mm	
139.07	5.33	mm	R1260
139.07	6.99	mm	R1307
139.30	3.53	mm	R1181
139.37	2.62	mm	R1110

NAK 標準型式

# O-ring

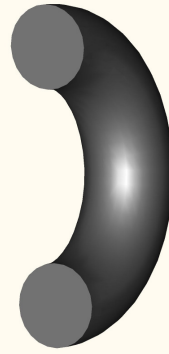
 材質：丁腈橡膠(NBR)  
 氟素橡膠(FKM)

尺寸		單位	圖號
內徑	線徑		
139.4	3.1	mm	R3024
139.6	5.7	mm	R2080
140	2	mm	
140	4	mm	
140	6	mm	
141.3	2	mm	R0722
142.24	5.33	mm	R1261
142.24	6.99	mm	R1308
142.47	3.53	mm	R1182
144	4	mm	
144.3	5.7	mm	
144.4	3.1	mm	R3025
144.5	2.0	mm	R0687
144.6	5.7	mm	R2081
144.94	1.95	mm	R0505
145	4	mm	
145.42	5.33	mm	R1262
145.42	6.99	mm	R1309
145.64	3.53	mm	R1183
145.72	2.62	mm	R1111
146.1	4.2	mm	R0694
148.59	5.33	mm	R1263
148.59	6.99	mm	R1310
148.82	3.53	mm	R1184
149.3	5.7	mm	R3026
149.4	3.1	mm	R0688
149.5	2.2	mm	
149.5	8.4	mm	R2083
149.6	5.7	mm	R2082
150	2	mm	
150	2.5	mm	R0203
150	4	mm	
150	6	mm	
151.77	5.33	mm	R1264
151.77	6.99	mm	R1311
151.99	3.53	mm	R0582

尺寸		單位	圖號
內徑	線徑		
152	3.53	mm	R1185
152.07	2.62	mm	R1112
154.3	5.7	mm	R3027
154.5	8.4	mm	R2084
158.12	5.33	mm	R1265
158.12	6.99	mm	R1312
158.34	3.53	mm	R1186
158.42	2.62	mm	R1113
159.3	5.7	mm	R3028
159.5	8.4	mm	R2085
160	6	mm	R0433
164.3	3.1	mm	
164.3	5.7	mm	R3029
164.4	3.1	mm	R0689
164.47	5.33	mm	R1266
164.47	6.99	mm	R1313
164.5	2.4	mm	
164.5	8.4	mm	R2086
164.70	3.53	mm	R1187
164.77	2.62	mm	R1114
165	5	mm	
169.3	3.1	mm	
169.3	5.7	mm	R3030
169.5	8.4	mm	R2087
170	3	mm	R0426
170	6	mm	
170.82	5.33	mm	R1267
170.82	6.99	mm	R1314
171.04	3.53	mm	R1188
171.12	2.62	mm	R1115
174.3	5.7	mm	R3031
174.5	8.4	mm	R2088
175	6	mm	
177	1.5	mm	
177.17	5.33	mm	R1268
177.17	6.99	mm	R1315

E5

NAK 標準型式

# O-ring

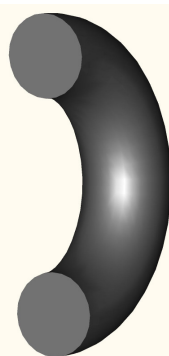
 材質：丁腈橡膠(NBR)  
 氟素橡膠(FKM)

E5

尺寸		單位	圖號
內徑	線徑		
177.39	3.53	mm	R1382
177.40	3.53	mm	R1189
177.47	2.62	mm	R1116
7.040	7.820	0.405/0.310 inch	A0011
179.3	3.1	mm	
179.3	5.7	mm	R3032
179.5	8.4	mm	R2089
180	4	mm	
180	6	mm	
183.52	5.33	mm	R1269
183.52	6.99	mm	R1316
183.74	3.53	mm	R1190
183.82	2.62	mm	R1117
184	3	mm	R0424
184.3	5.7	mm	R3033
184.5	8.4	mm	R2090
185	4	mm	
185	6	mm	
187	3	mm	
189.3	5.7	mm	R3034
189.5	8.4	mm	R2091
189.87	5.33	mm	R1270
189.87	6.99	mm	R1317
190	3	mm	R0361
190	4	mm	
190	6	mm	
190.09	3.53	mm	R1191
190.17	2.62	mm	R1118
193	3	mm	
193	8	mm	R0589
194	8	mm	
194.3	5.7	mm	R3035
194.5	8.4	mm	R2092
195	6	mm	
195	8	mm	R8086
196.22	5.33	mm	R1271

尺寸		單位	圖號
內徑	線徑		
196.22	6.99	mm	R1318
196.44	3.53	mm	R1192
196.52	2.62	mm	R1119
197	3.5	mm	
198	3	mm	R0425
199	3	mm	R0201
199.3	5.7	mm	R3036
199.5	8.4	mm	R2093
200	3	mm	
200	4	mm	
200	6	mm	
202.57	5.33	mm	R1272
202.57	6.99	mm	R1319
202.79	3.53	mm	R1193
202.87	2.62	mm	R1120
204	3	mm	R0423
204.5	8.4	mm	R2094
205	6	mm	
207.5	5.7	mm	
208.5	8.4	mm	R2095
208.9	6.99	mm	R1320
208.92	5.33	mm	R1273
209.14	3.53	mm	R1194
209.22	2.62	mm	R1121
209.3	5.7	mm	R3037
209.5	8.4	mm	R2096
210	6	mm	
211.8	3	mm	
214	3	mm	R0422
214.5	8.4	mm	R2097
215	6	mm	
215.27	5.33	mm	R1274
215.27	6.99	mm	R1321
215.50	3.53	mm	R1195
215.57	2.62	mm	R1122
219.3	5.7	mm	R3038

NAK 標準型式

# O-ring

 材質：丁腈橡膠(NBR)  
 氟素橡膠(FKM)

尺寸		單位	圖號
內徑	線徑		
219.5	8.4	mm	R2098
220	6	mm	
221.60	6.99	mm	R1322
221.62	5.33	mm	R1275
221.84	3.53	mm	R1196
221.92	2.62	mm	R1123
222.3	3.1	mm	R0753
223	3	mm	R0432
224.3	5.7	mm	
224.5	8.4	mm	R2099
224.9	3.53	mm	
227	4	mm	R0683
227.97	5.33	mm	R1276
227.97	6.99	mm	R1323
228.19	3.53	mm	R1197
228.20	3.53	mm	R1197
228.27	2.62	mm	R1124
229.3	5.7	mm	R3039
229.5	8.4	mm	R2100
230	6	mm	
232	3	mm	
234	3	mm	R0431
234.3	5.7	mm	
234.3	6.99	mm	R1324
234.32	5.33	mm	R1277
234.5	8.4	mm	R2101
234.55	3.53	mm	R1198
234.62	2.62	mm	R1125
235	10	mm	
239.3	5.7	mm	R3040
239.5	8.4	mm	R2102
240	4	mm	
240	5	mm	
240	6	mm	
240.67	5.33	mm	R1278
240.67	6.99	mm	R1325

尺寸			單位	圖號
內徑	線徑			
240.90	3.53		mm	R1199
244.5	8.4		mm	R2103
245	5		mm	
246	5.33		mm	R0637
247	6.99		mm	R1326
247.02	5.33		mm	R1279
247.25	3.53		mm	R1200
247.32	2.62		mm	R1127
249.3	5.7		mm	R3041
249.5	8.4		mm	R2104
253.37	5.33		mm	R1280
253.37	6.99		mm	R1327
9.980	10.760	0.405/0.310	inch	A0013
253.60	3.53		mm	R1201
254.3	5.7		mm	
254.5	8.4		mm	R2105
259.3	5.7		mm	R3042
259.5	8.4		mm	R2106
259.7	6.99		mm	R1328
261	5		mm	R0718
264	3		mm	R0430
264.5	8.4		mm	R2107
265	3		mm	
266.07	5.33		mm	R1281
266.07	6.99		mm	R1329
266.29	3.53		mm	R1202
269.3	5.7		mm	R3043
269.5	8.4		mm	R2108
270	4		mm	
272	3		mm	R0429
272.4	6.99		mm	R1330
274.5	8.4		mm	R2109
278.77	5.33		mm	R1282
278.77	6.99		mm	R1331
278.99	3.53		mm	R1203
279.3	5.7		mm	R3044

E5

NAK 標準型式

# O-ring

 材質：丁腈橡膠(NBR)  
 氟素橡膠(FKM)

E5

尺寸		單位	圖號
內徑	線徑		
279.5	8.4	mm	R2110
284	6	mm	R0202
284.5	8.4	mm	R2111
285.1	6.99	mm	R1332
285.6	3.4	mm	R0571
289.3	5.7	mm	R3045
289.5	8.4	mm	R2112
290	4	mm	
291.47	5.33	mm	R1283
291.47	6.99	mm	R1333
291.69	3.53	mm	R1204
294.5	8.4	mm	R2113
295	3	mm	R0074
297.87	6.99	mm	R1334
299.3	5.7	mm	R3046
299.5	8.4	mm	R2114
300	5.5	mm	R0599
304.17	5.33	mm	R1284
304.17	6.99	mm	R1335
304.39	3.53	mm	R1205
310	3	mm	R0428
310	4	mm	
310	10	mm	R0710
312	4.1	mm	R0636
314.5	8.4	mm	R2117
315	4	mm	
316.87	6.99	mm	R1336
319.2	3.53	mm	
319.3	5.7	mm	
319.5	8.4	mm	R2118
320	5.5	mm	R0597
325	5.5	mm	R0596
329.5	8.4	mm	R2120
329.57	5.33	mm	R1285
329.57	6.99	mm	R1337
329.79	3.53	mm	R1206

尺寸		單位	圖號
內徑	線徑		
334.5	8.4	mm	R2121
335	3	mm	R0427
339.5	8.4	mm	R2122
342.27	6.99	mm	R1338
342.27	7	mm	
344.5	8.4	mm	R2123
349.5	8.4	mm	R2124
351.5	8.4	mm	
354.5	8.4	mm	R2125
354.97	5.33	mm	R1286
354.97	6.99	mm	R1339
355.19	3.53	mm	R1207
356.5	3.63	mm	R0635
359.5	8.4	mm	R2126
360	5.5	mm	R0593
364.5	8.4	mm	R2127
367	3.5	mm	
367.67	6.99	mm	R1340
369.5	8.4	mm	R2128
374.5	8.4	mm	R2129
379.5	8.4	mm	R2130
380.37	5.33	mm	R1287
380.37	6.99	mm	R1341
380.59	3.53	mm	R1208
384.5	8.4	mm	R2131
389.5	8.4	mm	R2132
393.07	6.99	mm	R1342
394.5	8.4	mm	R2133
399.5	8.4	mm	R2134
405.26	3.53	mm	R1209
405.26	5.33	mm	R1288
405.26	6.99	mm	R1343
415	8	mm	R0594
416	10	mm	
417.96	6.99	mm	R1344
430.66	3.53	mm	R1210







NAK 標準型式

# X-ring

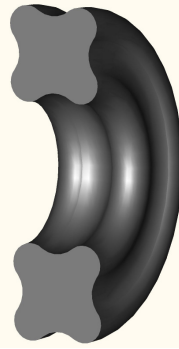
 材質：丁腈橡膠(NBR)  
 氟素橡膠(FKM)

E5

尺寸		單位	圖號
內徑	線徑		
0.74	1.02	mm	R4008
1.07	1.27	mm	R4057
1.25	2.62	mm	R4265
1.42	1.52	mm	R4058
1.78	1.78	mm	R4059
2.06	2.62	mm	R4266
2.57	1.78	mm	
2.84	2.62	mm	R4273
2.9	1.78	mm	
3.63	2.62	mm	R4259
3.68	1.78	mm	
4.34	3.53	mm	R4324
4.42	2.62	mm	
4.48	1.78	mm	R4084
5.23	2.62	mm	R4233
5.28	1.78	mm	R4085
5.94	3.53	mm	
6.02	2.62	mm	R4091
6.07	1.78	mm	
7.52	3.53	mm	R4245
7.59	2.62	mm	
7.65	1.78	mm	R4099
9.12	3.53	mm	R4311
9.19	2.62	mm	R4115
9.25	1.78	mm	R4082
10.46	5.33	mm	R4247
10.69	3.53	mm	
10.77	2.62	mm	R4116
10.82	1.78	mm	R4052
11.5	1.3	mm	A0316
12.07	5.33	mm	R4248
12.29	3.53	mm	R4308
12.37	2.62	mm	R4100
12.42	1.78	mm	R4108
13.64	5.33	mm	
13.87	3.53	mm	

尺寸		單位	圖號
內徑	線徑		
13.94	2.62	mm	R4081
14	1.78	mm	R4149
14.25	3	mm	R0128
15.24	5.33	mm	
15.47	3.53	mm	
15.54	2.62	mm	R4006
15.6	1.78	mm	R4055
16.2	2.62	mm	R4231
16.82	5.33	mm	
17	2.3	mm	R4320
17.04	3.53	mm	
17.12	2.62	mm	R0213
17.17	1.78	mm	R4109
18.2	3.53	mm	R4294
18.42	5.33	mm	
18.66	3.53	mm	R4005
18.72	2.62	mm	R0173
18.77	1.78	mm	R4053
19.8	2.4	mm	R4264
19.99	5.33	mm	R4249
20.07	2.62	mm	
20.22	3.53	mm	R4133
20.29	2.62	mm	R4117
20.3	2.62	mm	
20.35	1.78	mm	R4110
20.8	2.4	mm	R4196
21.59	5.33	mm	R4250
21.82	3.53	mm	R4087
21.85	2.6	mm	R4314
21.89	2.62	mm	R0160
21.95	1.78	mm	R4004
22.72	3.53	mm	R4312
23.17	5.33	mm	
23.39	3.53	mm	R4106
23.47	2.62	mm	R4118
23.52	1.78	mm	R4060

NAK 標準型式

# X-ring

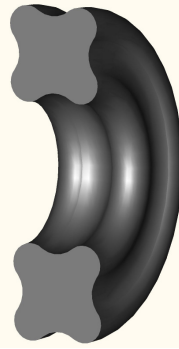
 材質：丁腈橡膠(NBR)  
 氟素橡膠(FKM)

尺寸		單位	圖號
內徑	線徑		
23.7	3.5	mm	R4198
24.77	5.33	mm	R4232
24.99	3.53	mm	R4134
25.07	2.62	mm	R4119
25.12	1.78	mm	R4111
25.37	6.99	mm	R4068
26.34	5.33	mm	
26.57	3.53	mm	R0178
26.58	3.53	mm	
26.64	2.62	mm	R4001
26.70	1.78	mm	R4112
27.7	3.5	mm	R4195
27.94	5.33	mm	
28.17	3.53	mm	R4095
28.24	2.62	mm	R4120
28.3	1.78	mm	R4061
29.52	5.33	mm	
29.74	3.53	mm	R4135
29.82	2.62	mm	R4121
29.87	1.78	mm	R4062
31.34	35.3	mm	R0180
31.42	2.62	mm	R4122
31.47	1.78	mm	R4063
32.2	2.6	mm	R0214
32.47	5.33	mm	
32.69	5.33	mm	
32.92	3.53	mm	R4051
32.99	2.62	mm	R4123
33.05	1.78	mm	R4064
34.1	3.53	mm	R0130
34.25	3	mm	R0129
34.29	5.33	mm	R4218
34.52	3.53	mm	R4136
34.59	2.62	mm	R4124
34.65	1.78	mm	R4056
36.09	3.53	mm	R4105

尺寸		單位	圖號
內徑	線徑		
36.17	2.62	mm	R4003
37.47	5.33	mm	R4151
37.47	5.34	mm	
37.69	3.53	mm	R4137
37.77	2.62	mm	R4125
37.82	1.78	mm	R4150
39.34	2.62	mm	R4126
40.04	3.53	mm	
40.65	5.34	5.34 mm	R4152
40.87	3.53	mm	R4138
40.94	2.62	mm	R4127
41	1.78	mm	R4179
42.52	2.62	mm	R4009
43.82	5.33	mm	R4153
43.82	5.34	mm	
44.04	3.53	mm	R4139
44.12	2.62	mm	R4010
44.17	1.78	mm	R4093
45.69	2.62	mm	R4128
46.99	5.33	mm	R4154
46.99	5.34	mm	
47.22	3.53	mm	R4140
47.29	2.62	mm	R4203
47.35	1.78	mm	R4180
48.9	2.62	mm	R4204
50.17	5.33	mm	R4155
50.17	5.34	mm	
50.39	3.53	mm	R4141
50.47	2.62	mm	R4205
50.52	1.78	mm	R4181
52.07	2.62	mm	R4129
53.34	5.33	mm	R4156
53.34	5.34	mm	
53.57	3.53	mm	R4002
53.64	2.62	mm	R4206
53.7	1.78	mm	R4103

E5

NAK 標準型式

# X-ring

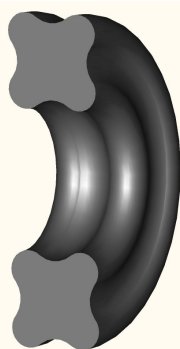
 材質：丁腈橡膠(NBR)  
 氟素橡膠(FKM)

E5

尺寸		單位	圖號
內徑	線徑		
55.25	2.62	mm	R4130
55.44	1.78	mm	R4163
56.52	5.33	mm	R4157
56.52	5.34	mm	
56.74	3.53	mm	R4142
56.82	2.62	mm	R4207
56.87	1.78	mm	R4182
58.42	2.62	mm	R4208
59.0	1.78	mm	R0102
59.5	72.5	5.4 mm	R4159
59.69	5.33	mm	R4164
59.69	5.34	mm	
59.92	3.53	mm	R4143
59.99	2.62	mm	R4209
60.05	1.78	mm	R4183
61.6	2.62	mm	R4210
62.87	5.33	mm	R4165
62.87	5.34	mm	
63.09	3.53	mm	R4011
63.17	2.62	mm	R4160
63.22	1.78	mm	R4113
63.25	3.5	mm	R4316
64.77	2.62	mm	R4131
66.04	5.33	mm	R4166
66.04	5.34	mm	
66.27	3.53	mm	R4012
66.34	2.62	mm	R4158
66.4	1.78	mm	R4199
67.95	2.62	mm	R4132
69.20	5.33	mm	
69.22	5.33	mm	R4167
69.3	3.5	mm	R4317
69.44	3.53	mm	R4013
69.52	2.62	mm	R4211
69.57	1.78	mm	R4185
71.12	2.62	mm	R4212

尺寸		單位	圖號
內徑	線徑		
72.39	5.33	mm	R4168
72.62	3.53	mm	R4014
72.69	2.62	mm	R4213
72.75	1.78	mm	R4187
73.07	3.5	mm	R4315
75.57	5.33	mm	R4169
75.57	5.34	mm	
75.79	3.53	mm	R4016
75.87	2.62	mm	R4214
75.92	1.78	mm	R4188
78.74	5.33	mm	R4170
78.74	5.34	mm	
78.97	3.53	mm	R4017
81.92	5.33	mm	R4171
81.92	5.34	mm	
82.14	3.53	mm	R4018
82.22	2.62	mm	R4215
82.27	1.78	mm	R4189
85.09	5.33	mm	R4172
85.09	5.34	mm	
85.32	3.53	mm	R4019
88.27	5.33	mm	R4173
88.27	5.34	mm	
88.49	3.53	mm	R4020
88.57	2.62	mm	R4186
88.62	1.78	mm	R4190
91.44	5.33	mm	R4174
91.44	5.34	mm	
91.67	3.53	mm	R4021
94.62	5.33	mm	R4175
94.62	5.34	mm	
94.84	3.53	mm	R4022
94.92	2.62	mm	R4216
94.97	1.78	mm	R4191
97.79	5.33	mm	R4025
98.02	3.53	mm	R4023

NAK 標準型式

# X-ring

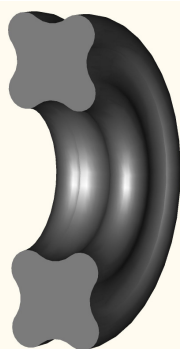
 材質：丁腈橡膠(NBR)  
 氟素橡膠(FKM)

尺寸		單位	圖號
內徑	線徑		
100.97	5.33	mm	R4026
101.19	3.53	mm	R4024
101.27	2.62	mm	R4217
101.32	1.78	mm	R4192
104.14	5.33	mm	R4027
104.37	3.53	mm	R4145
107.32	5.33	mm	R4176
107.54	3.53	mm	R4277
107.62	2.62	mm	R4219
107.67	1.78	mm	R4193
110.49	5.33	mm	R4028
110.72	3.53	mm	R4088
113.66	5.33	mm	
113.67	5.33	mm	R4029
113.67	7	mm	R4030
113.89	3.53	mm	R4276
113.97	2.62	mm	R4220
114.02	1.78	mm	R4194
116.84	5.33	mm	
116.84	7	mm	R4031
117.07	3.53	mm	
120.02	5.33	mm	
120.02	6.99	mm	R4178
120.24	3.53	mm	R4293
120.32	2.62	mm	R4221
120.37	1.78	mm	R4200
123.19	5.33	mm	
123.19	7	mm	R4032
123.42	3.53	mm	R4279
126.37	5.33	mm	
126.37	7	mm	R4033
126.59	3.53	mm	R4146
126.67	2.62	mm	R4222
126.72	1.78	mm	R4201
129.54	5.33	mm	R4177
129.54	6.99	mm	R4034

尺寸		單位	圖號
內徑	線徑		
129.77	3.53	mm	R4283
132.72	5.33	mm	
132.72	6.99	mm	R4035
132.94	3.53	mm	R4104
133.02	2.62	mm	
133.07	1.78	mm	R4202
135.89	5.33	mm	
135.89	6.99	mm	R4050
135.89	7	mm	R4096
136.12	3.53	mm	R4282
139.07	5.33	mm	
139.07	7	mm	R4036
139.3	3.53	mm	R4301
139.37	2.62	mm	R4224
142.24	5.33	mm	
142.24	6.99	mm	R4037
142.47	3.53	mm	
145.42	5.33	mm	
145.42	6.99	mm	R4038
145.64	3.53	mm	R4147
145.65	3.53	mm	A0732
145.72	2.62	mm	R4296
148.58	6.99	mm	R4039
148.59	5.33	mm	
148.82	3.53	mm	
151.77	5.33	mm	
151.77	6.99	mm	R4079
151.77	7	mm	R4097
151.99	3.53	mm	R4089
152.07	2.62	mm	R4226
158.12	5.33	mm	R4291
158.12	6.99	mm	R4040
158.35	3.53	mm	
158.42	2.62	mm	R4227
160.5	6.98	mm	R4325
160.5	7	mm	R0400

E5

NAK 標準型式

# X-ring

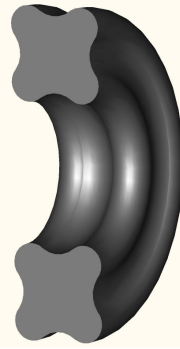
 材質：丁腈橡膠(NBR)  
 氟素橡膠(FKM)

E5

尺寸		單位	圖號
內徑	線徑		
161.02	6.99	mm	R0059
164.47	5.33	mm	R4280
164.47	6.99	mm	R4041
164.7	3.53	mm	R4302
164.77	2.62	mm	R4228
170.82	5.33	mm	R4304
170.82	6.99	mm	R4042
171.04	3.53	mm	
171.12	2.62	mm	R4284
177.17	5.33	mm	R4290
177.17	6.99	mm	R4043
177.4	3.53	mm	
177.47	2.62	mm	R4234
183.52	5.33	mm	R4161
183.52	5.34	mm	
183.52	6.99	mm	R4045
183.74	3.53	mm	
183.82	2.62	mm	
189.87	5.33	mm	
189.87	7	mm	R4044
190.1	3.53	mm	
190.17	2.62	mm	R4235
196.22	5.33	mm	
196.22	7	mm	R4046
196.44	3.53	mm	
196.52	2.62	mm	R4236
202.57	5.33	mm	
202.57	7	mm	R4015
202.80	3.53	mm	
202.87	2.62	mm	R4237
208.92	5.33	mm	
209.14	3.53	mm	
209.22	2.62	mm	R4238
215.27	5.33	mm	R4090
215.27	6.99	mm	R4065
215.50	3.53	mm	

尺寸		單位	圖號
內徑	線徑		
215.57	2.62	mm	R4239
221.62	5.33	mm	
221.84	3.53	mm	R4246
221.92	2.62	mm	R4240
227.97	5.33	mm	R4298
227.97	6.99	mm	R4066
228.20	3.53	mm	
228.27	2.62	mm	R4241
234.32	5.33	mm	
234.55	3.53	mm	R4267
234.62	2.62	mm	R4242
240.67	5.34	mm	R4007
240.67	6.99	mm	R4067
240.90	3.53	mm	
240.97	2.62	mm	R4243
247.02	5.33	mm	
247.25	3.53	mm	
247.32	2.62	mm	R4244
253.37	5.33	mm	R4229
253.37	6.99	mm	R4068
253.6	3.53	mm	
266.07	5.33	mm	R4230
266.07	6.99	mm	R4069
266.29	3.53	mm	
278.77	5.33	mm	R4272
278.77	6.99	mm	R4070
278.99	3.53	mm	R4297
291.47	5.33	mm	R4162
291.47	6.99	mm	R4049
291.69	3.53	mm	
304.17	5.33	mm	
304.17	6.99	mm	R4071
304.39	3.53	mm	
316.87	6.99	mm	R4072
329.57	5.33	mm	R4263
329.57	6.99	mm	R4073







NAK 標準型式

# SQ-ring

 材質：丁腈橡膠(NBR)  
 氟素橡膠(FKM)

E5

尺寸			單位	圖號
內徑	外徑	厚度		
3.7	7.6	0.95	mm	R8454
5	13	3	mm	R8192
5.2	1.8	1.8	mm	A0514
5.57	36.2	1.4	mm	R8099
5.6	27.15	1.4	mm	R8098
6	1.75/1.75		mm	R0359
8	13	1.08	mm	R8232
8.5	14.5	5	mm	R8440
0.346	0.536	0.182	inch	R0534
10.67	15.25	2.93	mm	R0310
0.5	0.0625		inch	R0399
13.8	2.7	2.7	mm	A0510
15	19	1.7	mm	R0355
15.3	2.5/2		mm	R0303
18	22	3.8	mm	R8102
20	23	1.6	mm	R8191
20.32	23.11	1.45	mm	R8248
21.1	31.5	4.9	mm	R8215
21.3	37.6	1.65	mm	R8465
21.5	25.5	3.8	mm	R8103
21.5	27.8	3.75	mm	R8205
22	28	8	mm	R0533
22.5	29.2	3.5	mm	R8125
23.3	26.7	1.8	mm	R8311
23.5	30	2.6	mm	R0463
23.52	1.68		mm	R8133
23.6	1.7		mm	R0020
24	39.5	1.5	mm	R8100
25	29	3.8	mm	R8104
26	62	4	mm	R8114
28.5	40	0.8	mm	A0939
30	12.5	10	mm	R0484
30.5	36.5	3.15	mm	R0528
31	39	6.2	mm	R8105
32	38.5	3.2	mm	R8101
32	39	5	mm	R8106

尺寸			單位	圖號
內徑	外徑	厚度		
32.4	37.4	2.8	mm	R8439
32.6	37.6	2.5	mm	R8307
32.7	37.9	2.5	mm	R8324
33	1.75/1.75		mm	R0360
34	38	3.75	mm	R8107
34.3	40.3	3.2	mm	R8420
35	41	2.5	mm	R8203
35	41	3	mm	R8034
35	46.4	0.8	mm	53601
35.3	45.5	1.0	mm	50566
36	40	0.5	mm	50465
36	42	3.15	mm	R0529
36.5	2.7		mm	A0512
38	48.3	0.5	mm	53055
38.2	44.5	3.2	mm	R0315
38.5	43	2.7	mm	R8457
38.5	44.8	3.2	mm	R8284
38.6	44.6	3.3	mm	R8159
38.7	56.9	4	mm	R8271
38.8	44.8	3.0	mm	51377
39.1	44.3	2.5	mm	R8325
39.5	45.5	3.25	mm	R8158
39.7	46.1	4.4	mm	U7841
39.9	3		mm	
40	46	3	mm	R8035
40.5	48.05	0.8	mm	50564
40.6	48	2.7	mm	A0037
41.0	47.2	3.2	mm	R0312
41.4	46.4	2.5	mm	R8308
41.4	47.4	3.2	mm	R8282
42	48	3	mm	R8036
42	50	6.2	mm	R8108
42	56	2	mm	A2029
42.65	48.65	3.2	mm	R8241
43	48	2.5	mm	R8414
43	49	2.8	mm	R8302

NAK 標準型式

# SQ-ring

 材質：丁腈橡膠(NBR)  
 氟素橡膠(FKM)

尺寸			單位	圖號
內徑	外徑	厚度		
43	49	3	mm	R8037
44	52	0.8	mm	49654
44.45	50.47	3.18	mm	R0600
45	49.5	0.8	mm	49655
45	51	3	mm	R8038
45.0	51.1	3.2	mm	R0313
45.5	2.5	2.5	mm	A0509
46	49.7	6.2	mm	R8272
46	52	3.25	mm	R8329
46.7	50.38	0.8	mm	50490
47	1.6		mm	A0513
47	53	3	mm	R8160
47	58.3	5.5	mm	U7842
47.25	53.25	3.2	mm	R8242
47.5	76.2	14/15.7	mm	51747
47.74	53.65	3.18	mm	R8072
47.74	55.65	3.18	mm	
48	54	3	mm	R8039
48	68	1.8	mm	R0522
48.3	54.3	3.2	mm	R8415
48.5	52.5	2.5	mm	R8008
48.8	54.8	3.25	mm	R8413
50	110	4	mm	R8115
50.5	56.5	3.4	mm	R8438
50.8	55.9	2.85	mm	R8408
51	57	3	mm	R8040
51	3/1.9		mm	R0304
51.2	56	2.4	mm	R8212
51.6	56.8	2.6	mm	R8312
52.07	57.09	2.51	mm	R8135
53	60.55	1	mm	50562
53.9	60	3.2	mm	R8418
54	60	3	mm	R8041
54.2	60	3.2	mm	R0511
54.4	60.4	3.2	mm	R0531
55	60	2.7	mm	R8109

尺寸			單位	圖號
內徑	外徑	厚度		
55.07	61.13	3.17	mm	R0206
55.5	61.5	3.2	mm	R0236
56	71	4	mm	R0481
56.6	61.8	2.5	mm	R8323
57	63	3	mm	R8042
57	63	6.2	mm	R8110
57.5	62.5	2.5	mm	R8254
57.7	63.6	3.2	mm	R0311
58.80	2.50		mm	R0021
59	64	2.5	mm	R8280
59.7	65.8	3.15	mm	R8417
60	66	3	mm	R8043
60	70.2	0.8	mm	53595
60.4	66.5	3.2	mm	R0314
60.5	66.5	3	mm	R8044
61	67	3	mm	51385
61.5	2.5	2.5	mm	A0508
62.5	69.3	3.4	mm	R8315
2.470	2.830	0.245	inch	R8139
62.95	70.5	1.85	mm	R0382
63	66.5	2	mm	R0470
63.09	69.89	3.40	mm	R8136
63.5	68.6	2.85	mm	R8409
64.5	70.5	3	mm	R0485
65	70.5	5.5	mm	R8111
65	73	1	mm	50573
65	80	8	mm	50575
65.2	73.8	5	mm	R8211
66	78	0.5	mm	50574
66.5	72.5	3.9	mm	R8214
67.5	74.8	3.3	mm	R8433
69.3	3.4		mm	R0022
69.50	3.50		mm	R8152
70	73	1.1	mm	42657
71	2.6	2.6	mm	A0511
72.2	79.20	3.50	mm	R8309

E5







# 設計履歷

客戶/部門	客戶編號	日期
地址	城市/州別/郵遞區號	接洽者
電話	傳真	E-mail

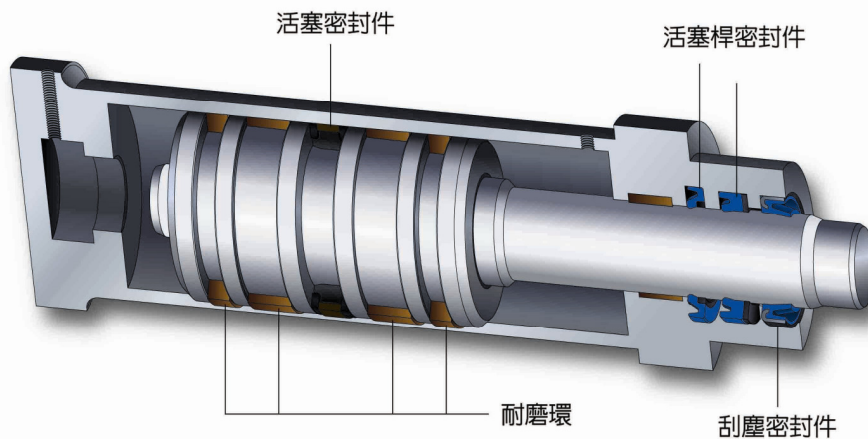

應用環境		使用設備		每年使用量	<input type="checkbox"/> OEM
				每月使用量	
膠料物性	<input type="checkbox"/> 依NAK標準 (ASTM) <input type="checkbox"/> 依客戶規範			特殊操作說明：	
品質檢驗	<input type="checkbox"/> 依NAK標準 (AQL 4.0, C=0) <input type="checkbox"/> 依客戶規範				
設計依據	<input type="checkbox"/> 依NAK標準 <input type="checkbox"/> ODM <input type="checkbox"/> 客戶原樣 <input type="checkbox"/> 客戶原圖				
溫度					
最低	正常	最高	<input type="checkbox"/> °C <input type="checkbox"/> °F		
壓力					
最低	正常	最高	<input type="checkbox"/> Bar <input type="checkbox"/> Psi <input type="checkbox"/> Mpa		
密封流體					
種類	廠牌與等級		黏度		
速度					
循環週期數/ 每分鐘	行程		平均速度		

## 安裝位置與尺寸

A. 動態密封面尺寸： \_\_\_\_\_

D. 最小導角尺寸： \_\_\_\_\_

B. 靜態密封面尺寸： \_\_\_\_\_

E. 靜態密封面尺寸： \_\_\_\_\_

C. 靜態溝槽密封面尺寸： \_\_\_\_\_

### 活塞 1：

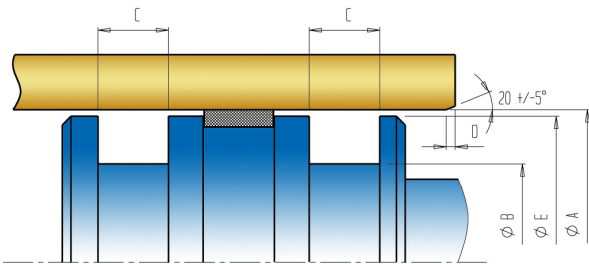

### 活塞 2：

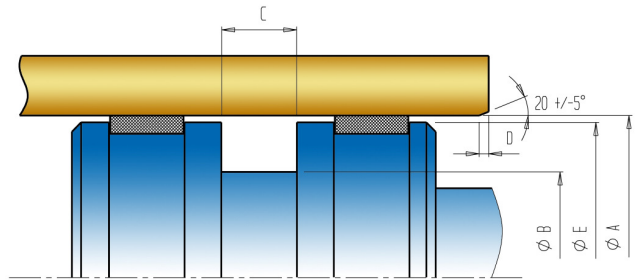

A. 動態密封面尺寸： \_\_\_\_\_

D. 最小導角尺寸： \_\_\_\_\_

B. 靜態密封面尺寸： \_\_\_\_\_

E. 動態密封面尺寸： \_\_\_\_\_

C. 靜態溝槽密封面尺寸： \_\_\_\_\_

F. 最小導角尺寸： \_\_\_\_\_

### 活塞桿 1：

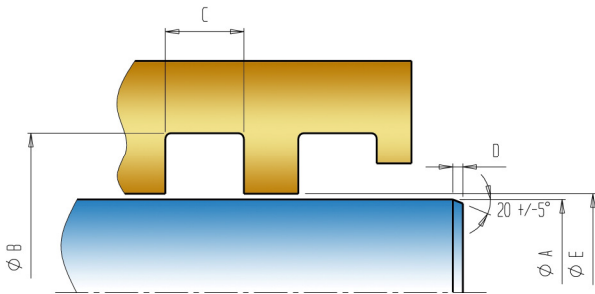

### 活塞桿 2：

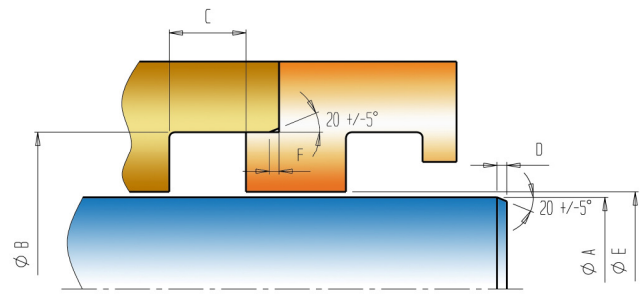

A. 動態密封面尺寸： \_\_\_\_\_

D. 最小導角尺寸： \_\_\_\_\_

B. 靜態密封面尺寸： \_\_\_\_\_

E. 動態密封面尺寸： \_\_\_\_\_

C. 靜態溝槽密封面尺寸： \_\_\_\_\_

F. 最小導角尺寸： \_\_\_\_\_

### 刮塵 1：

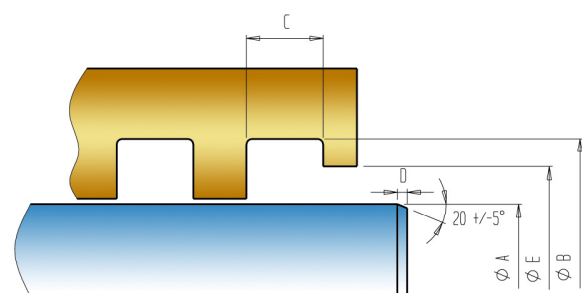

### 刮塵 2：

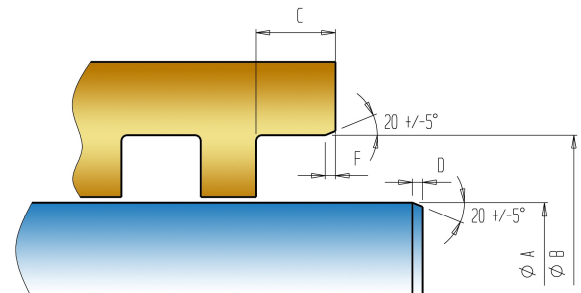







# 茂順全球分佈圖

● 工廠 ● 服務據點與發貨倉庫 ● 服務據點



## Taiwan (NAK Headquarters)

茂順密封元件科技股份有限公司  
南投市南崗工業區工業路336號 54065 台灣  
TEL : 886-49-2255011  
FAX : 886-49-2250035  
E-mail : service@mail.nak.com.tw  
www.nak.com.tw

## China

昆山茂順密封件工業有限公司  
江蘇省昆山市周市鎮新浦路271號 郵編：215337  
TEL : 86-512-57666240; 86-512-57665788  
FAX : 86-512-57665827; 86-512-57664409  
E-mail : sales@nak.com.cn  
www.ksnak.com

## Iran

KISH NAK OIL SEAL MFG. CO., LTD.  
No.67, Eshghyar St. Khorramshahr Ave.,  
Tehran 15339, Iran  
TEL : 98-21-88761965  
FAX : 98-21-88741319  
E-mail : kishnak@parsonline.net

## Thailand

NAK SEALING PRODUCTS(THAILAND) CO., LTD.  
120/36 Moo 12 Soi 21/2 Kingkaew-Bangplee Road, Tumbul  
Rachatewa, Ampur Bangplee Samutprakarn 10540, Thailand  
TEL : 66-2-750-1988  
FAX : 66-2-750-1868  
E-mail : sales@mail.thainak.com

## Russia

NAK INTERNATIONAL LTD.  
Russia, Postal Index 143956, Moscow Region, Balashiha,  
Mikroraion Nikolsko-Arhangelskiy, Vishnyakovskoe Shosse,  
56, "NAK INTERNATIONAL LTD."  
TEL : 7-495-545-94-00  
FAX : 7-495-646-79-29  
E-mail : info@naksealing.ru  
www.naksealing.ru

## India

NAK SEALING TECHNOLOGIES (INDIA)  
PRIVATE LIMITED  
P-1, Phase II, Dr.Vikram Sarabhai Industrial Estate,  
Thiruvanniyur, Chennai - 600 041, Tamilnadu, India.  
TEL : 91-44-64586657; 91-44-64586661  
E-mail : marketing@nakindia.com

## Brazil

NAK DO BRASIL INDUSTRIA E COMERCIO DE  
COMPONENTES DE VEDACAO LTDA  
Rua Soldado Benedito Eliseo Dos Santos, NRO 10 CEP  
02177-020, Sao Paulo S.P, Brazil  
TEL : 55-11-3807-3001  
FAX : 55-11-3807-3002  
E-mail : nakbrasil@nakbrasil.com.br  
comercial@nakbrasil.com.br

### 免責聲明

1. NAK產品並未被意圖使用、安裝或應用於任何與航空相關之儀器或設備。任何此類的使用、安裝或應用係被禁止的，且將使任何明示或默示的擔保失其效力。
2. 有以下任一情況者，NAK不負任何明示或默示的擔保責任：
  - 2.1 被修改或被竄改
  - 2.2 被誤用、濫用或盜用
  - 2.3 被使用在嚴苛環境或特殊設備上，卻未取得NAK事先書面同意
  - 2.4 其使用未依照NAK材料說明書
  - 2.5 由於化學結構的自然老化、分解或硬化所致損害
3. 如果NAK的產品需被使用在特殊要求的環境或特定設備上，則必須在該產品之樣品得到NAK的正式技術確認並通過買方樣品測試之後，該產品才可進行量產。