



# 地矿工具合金

CEMENTED CARBIDE FOR  
MINING & CONSTRUCTION TOOLS



## 公司简介

厦门金鹭特种合金有限公司，是一家中外合资的国家级高新技术企业，是国有上市公司厦门钨业股份有限公司（股票代码：SH600549）的骨干成员。成立于1989年，主要从事钨粉、碳化钨粉、硬质合金、切削刀具等钨系列产品的生产；是中国最大的钨粉、碳化钨粉供应商和出口商；是高品质合金及其精密切削工具的制造商。

公司拥有一支自强不息的、高素质员工团队，拥有国际一流的工艺技术、生产设备和检测仪器；其生产的“金鹭”牌系列产品以优良的品质和完善的服务，享誉国内外；客户遍布全球四十多个工业发达国家和地区。

公司建立了国家级技术中心，独立承担并完成了多项“国家科技支撑计划”项目、“国家科技重大专项”项目、“国家科技攻关计划”项目、“国家火炬计划”项目、“国家重点新产品”开发项目及省市重点研究课题，被评为“国家重点高新技术企业”、“先进技术企业”、“出口型企业”。

公司坚持以诚信为本的理念，致力于不断创新、发展成为“设备一流”、“技术一流”、“管理一流”、“质量一流”、“服务一流”的现代化企业。

## ABOUT GESAC

Xiamen Golden Egret Special Alloy Co., Ltd. (GESAC) is a Sino-foreign joint venture company established in 1989. It is designated by the State as a high-tech enterprise. GESAC is the largest subsidiary of the Shanghai Stock Exchange listed company: Xiamen Tunsten Co., LTD. (Stock code: SH600549). Its main products are tungsten metal powder, tungsten carbide powder, cemented carbide, cutting tools and other tungsten related products. GESAC is the largest producer and exporter of tungsten metal powder and tungsten carbide powder in China and also enjoys good reputation in manufacturing high quality cemented carbide and precision cutting tools.

GESAC has a team of talented staff constantly striving to be stronger. GESAC is equipped with the world's most advanced technologies, manufacturing equipment and testing facilities. The "Golden Egret" brand products are renowned for high quality and excellent service. Our clients are spread across more than forty developed countries and regions all over the world.

GESAC owns a national level R&D center, and has undertaken and finished many national and provincial research projects independently, such as National Science and Technology Support Plan project, National major special science and technology project, National Key Technologies R&D Program, National Torch Program, National Important New Products project etc. GESAC has received numerous awards such as "National Standard High-tech Enterprise", "Enterprise with Advanced Technology" and "Export-oriented Enterprise" from the state government.

GESAC adheres to the philosophy of "sincerity and dependability are our essence" and strives to develop into a modern enterprise with "first class equipment, first class technology, first class management, first class quality and first class service".



● 金鹭工厂分布 | GESAC Facilities

## 产品链

### Product Chain

金鹭具有从矿石开采到钨粉末，硬质合金制品及精密切削刀具的完整的钨产品链。

GESAC has a complete tungsten product chain from tungsten ore to tungsten powder, cemented carbide products and cutting tools.

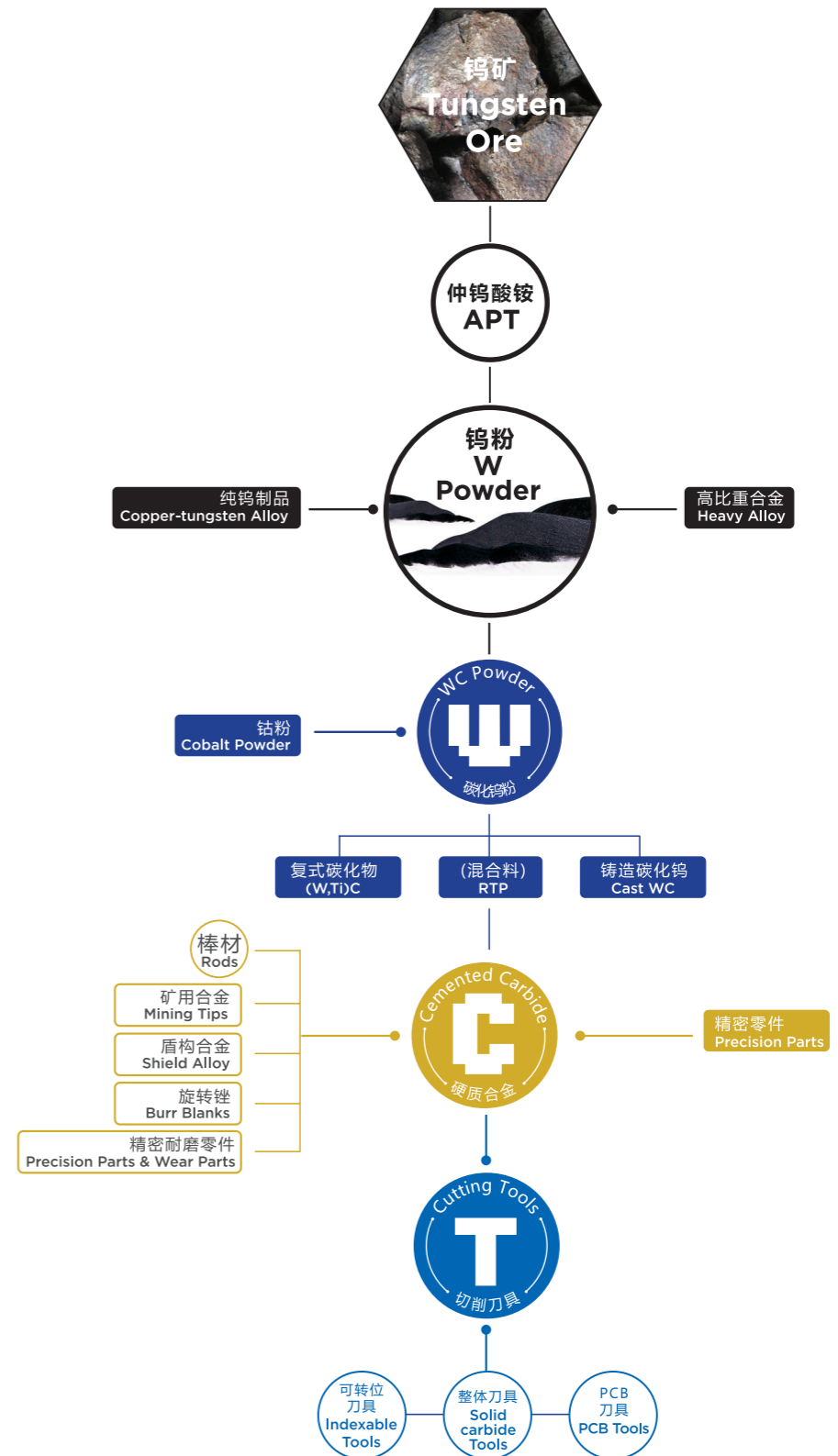

## 目录 Contents

### 基本信息 — A Basic Information

地矿工具合金产品分类 Product Category	002
常规合金牌号编码规则 The Rules of The Old Grades	004
新开发合金牌号编码规则 The Rules of The New Grades	004
型号表示规则 The Rules of The Codes	005
尺寸公差标准 Standard Tolerances	005

### 产品应用领域及信息 — B The Applications and Information of products

矿山开采用齿概况 Inserts for Mining	008
矿山开采用齿牌号 Grades for Mining	009
矿山开采用齿齿形 Shape of Inserts	010
油田牙轮钻齿概况 Inserts for Oilfield & Gas	018
油田牙轮钻齿牌号 Grades for Oilfield & Gas	019
油田牙轮钻齿齿形 Shape of Inserts for Oilfield & Gas	020
煤炭采掘用齿概况 Inserts for Coal Cutting	028
煤炭采掘用齿牌号 Grades for Coal Cutting	028
煤炭采掘用齿齿形 Shape of Inserts for Coal Cutting	029
工程、建筑用合金齿概况 Inserts for Construction	036
工程、建筑用合金齿牌号 Grades for Construction	037
工程、建筑用合金齿齿形 Shapes of Inserts	038

### 附录 — C Appendix

岩石硬度等级划分 Rock Hardness Grading	043
硬度换算表 Hardness Comparison	044

## 基本信息 Basic Information

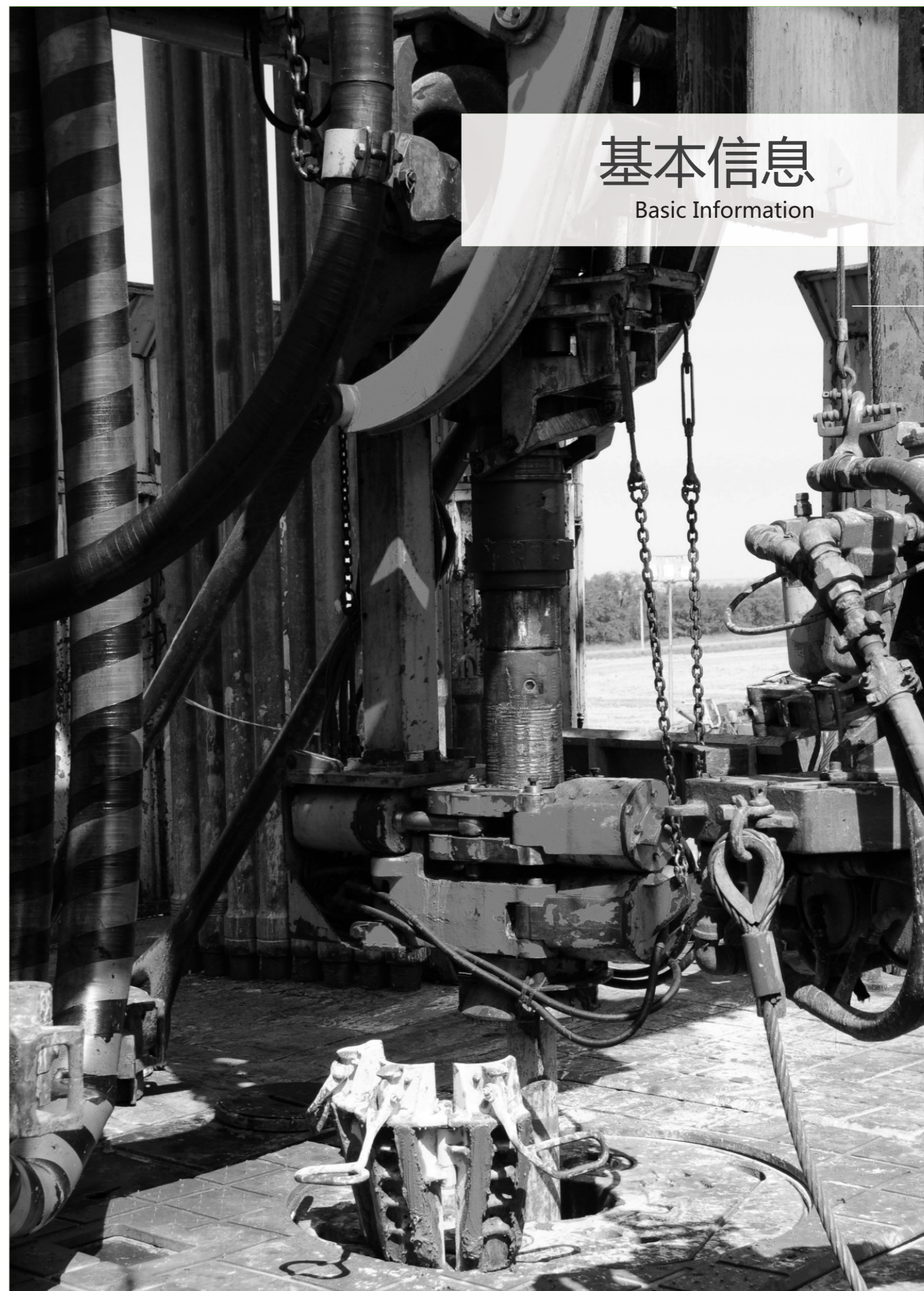

## 地矿工具合金产品分类

## Product Category

分类 Subcategory	常用牌号 Grades	相关齿形分类 Insert Classify by Shapes	齿形代码 Code of Shapes
矿山开采用齿 Inserts for Mining	GD25、GD25A、GD30A、GD30	边楔齿 Wedge Crested Chisel Inserts	SB
	GF20A、GF20Q、GL0602D、 GL0602H、GL1002R	弹形齿 Parabolic Inserts	SD
	GF20D、GF25D	平顶齿 Flat Inserts	SP
	GF20A、GF20Q、GD25 GL1002R、GL0602D、GL0602H	球形齿 Ovoid Inserts	SQ
	GF20A、GD25A、GD30A	锯齿齿 Serrated flat Inserts	SU
	GD25、GD25A、GD30A、GD30	楔形齿 Chisel Inserts	SX
	GF20A、GF20Q、GD25、GD25A、GD30A、 GD30、GL0602D、GL0602H、GL1002R	锥形齿 Conical Inserts	SZ
	GD30A	异形齿 Special-shaped Inserts	SY
油田牙轮钻齿 Inserts for Oilfield & Gas	GD25A、GD30F	边楔齿 Wedge Crested Chisel Inserts	SB
	GF20D、GF25D	平顶齿 Flat Inserts	SP
	GF20D、GD25A	球形齿 Ovoid Inserts	SQ
	GD25、GD60A、GD60C	勺形齿 Scoop Inserts	SS
	GF20D、GD25A	锯齿齿 Serrated flat Inserts	SU
	GD25A、GD30F、GD60、GD60A、GD60C	楔形齿 Chisel Inserts	SX
	GD25、GD25A、GD30F、GD60A	锥形齿 Conical Inserts	SZ

## 地矿工具合金产品分类

## Product Category

分类 Subcategory	常用牌号 Grades	相关齿形分类 Insert Classify by Shapes	齿形代码 Code of Shapes
煤矿截齿 Inserts for Coal Cutting	GF40	片状截齿 Flake Inserts for Coal Mine	M
	GD20A、GD30C、GL0809F、GL0812F、 GL0612C	柱状截齿 Columnar Inserts for Coal Cutting	SD、SZ
	GD30C、GL0809F、GL0812F	异形截齿 Special-shaped Inserts for Coal Cutting	SW、M
工程用齿 Inserts for Construction	GD10、GD10S、GL0603M、GL0605M	帽状路面铣刨齿 Cap-shaped Inserts for Road Plane Milling	SW
	GD10、GL0603M	柱状路面铣刨齿 Columnar Inserts for Road Plane Milling	SZ
	GD30C、GL0809F、GL0812F	旋挖齿 Rotary drilling Insert	SD
	GF50	地质勘探合金 Geological prospecting Insert	T

## 常规合金牌号编码规则

The Rules of The Old Grades



①：牌号分类码代表使用原料WC的平均晶粒度(WC Mean Grain Size)

GU类：≤0.8μ  
GK类：0.9μ-1.9μ  
GF类：2.0μ-3.9μ  
GD类：≥4.0μ

②：牌号分组号代表钴含量范围(Content of Co)

③：牌号细分号(Grade Subdivision)

## 新开发合金牌号编码规则

The Rules of The New Grades

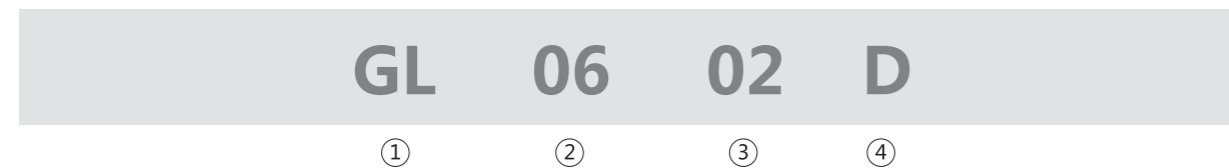

①：金鹭领先牌号 GESAC leading Grade

②：钴含量 Cobalt Content

③：合金平均晶粒度范围 WC Average Grain Size

④：合金产品应用领域范围 Typical Code of Applications

各应用领域 Applications	代表字母 Typical Code
锥度连接钎头齿 Tapered Drilling Bit	T
牙轮钻齿(油田、矿用) Rotary Bit	R
路面铣刨齿(沥青、水泥) Milling Bits for Road	M
截齿(挖渠、管道、煤矿、铁矿)或滚刀 Cutter	C
潜孔钻齿 DTH	D
螺纹钎头齿 Hydraulic Drilling Bit	H
旋挖钻齿 Foundation Drilling Bit	F

## 型号表示规则

The Rules of The Codes

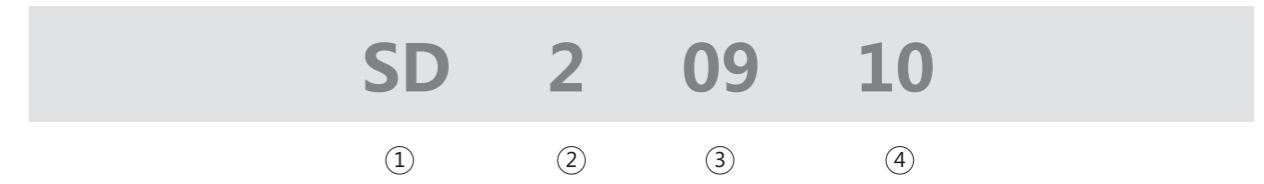

①：表示齿形(Shapes)

②：该齿形下部的形状系数(Specification)

③：柱齿外径(Outside Diameter)

④：柱齿高度(Height)

## 尺寸公差标准

Standard Tolerances

精品直径 Ground Diameter		毛坯直径 Blank Diameter		高度 Height	
标准尺寸 Diameter	公差 Tolerance	标准尺寸 Diameter	公差 Tolerance	标准尺寸 Height	公差 Tolerance
0~10	±0.003	0~10	+0.4/+0.2	0~10	±0.10
10~25	±0.004	10~15	+0.5/+0.2	10~15	±0.15
25~30	±0.005	15~30	+0.6/+0.2	15~30	±0.20
30~50	±0.006	30~50	+0.7/+0.2	30~50	±0.25

B

## 产品应用领域及信息

The Applications and Information of products



矿山开采用齿  
Inserts for mining

### 矿山开采用齿概况

Inserts For Mining

钻头类别 Classify by Bit	常用牌号 Grade	相关齿形 Shapes	齿形代码 Shape Code	应用工况 The Application Conditions
锥度钎头 Tapered Drilling Tools	GF20A	球形齿 Ovoid Insert	SQ	适用于极硬f15-f20岩层 Super Hard Rock Formation F15-F20
	GF20A	弹形齿 Parabolic Insert	SD	适用于中硬f10-f15岩层 Medium Hard Rock Formation F10-F15
	GF20A	锥形齿 Conical Insert	SZ	适用于中硬f10-f15岩层 Medium Hard Rock Formation F10-F15
螺纹钎头、 潜孔钻 Thread Drill Bit, Dth Bit	GF20Q、GL0602D、 GL0602H	球形齿 Ovoid Insert	SQ	适用于极硬f15-f20岩层 Super Hard Rock Formation F15-F20
	GF20Q、GL0602D、 GL0602H	弹形齿 Parabolic Insert	SD	适用于中硬f10-f15岩层 Medium Hard Rock Formation F10-F15
	GF20Q、GL0602D、 GL0602H	锥形齿 Conical Insert	SZ	适用于中硬f10-f15岩层 Medium Hard Rock Formation F10-F15
矿用牙轮钻头 Cone Bit	GD25、GD25A、 GD30A、GD30	边楔齿 Wedge Crested Chisel Insert	SB	适用于中硬f10-f15岩层的外排齿等 Medium Hard Rock Formation F10-F15
	GD25A、GD25、 GL1002R	弹形齿 Parabolic Insert	SD	适用于中硬f10-f15岩层 Medium hard rock formation f10-f15
	GF20D、GF25D	平顶齿 Flat Insert	SP	保径齿 Gauge Insert
	GD25A、GD25 GL1002R	球形齿 Ovoid Insert	SQ	适用于极硬f15-f20岩层 Super Hard Rock Formation F15-F20
	GF20A、GD25A、 GD30A	锯齿形齿 Serrated Falt Insert	SU	保径齿，对孔径精度要求较低 Gauge Insert
	GD25、GD25A、 GD30A、GD30、	楔形齿 Chisel Insert	SX	适用于中软f5-f10岩层 Medium Hard Rock Formation F5- F10
	GD30A	异形齿 Special-shaped Insert	SY	适用于软岩f3-f8层 Soft Rock Formation F3-F8
	GD25、GD25A、 GD30A、GD30 GL1002R	锥形齿 Conical Insert	SZ	适用于中硬f5-f10岩层 Medium Hard Rock Formation F5- F10

### 矿山开采用齿牌号及应用领域

Grades & Applications

牌号 Grade	钴含量 Cobalt (%)	密度Den. (g/cm <sup>3</sup> )	硬度 Hardness HRA	晶粒度 Grain Size	抗弯强度 TRS	牌号描述 Grades Descriptions
GL0602H	6	14.95	90.8	细 Fine	2600	改进牌号，高耐磨性和韧性，适用于各种规格的螺纹钎头齿，岩层为中硬岩层。 upgrade, excellent wear resistance and toughness, Suitable for thread drilling bits of various sizes. Can be used on medium hard rock formations.
GF20A	6	14.95	90.5	细 Fine	2800	高耐磨性，适用于各种锥度连接钎头齿，岩层为中硬岩层。 excellent wear resistance, Suitable for small size inserts for tapered drilling bits. Can be used on medium hard rock formations.
GL0602D	6	14.95	90.3	细 Fine	2600	改进牌号，高耐磨性和韧性，通用性强适用于各种规格高压的潜孔钻用齿，岩层为中硬岩层。 upgrade, excellent wear resistance and toughness, Suitable for DTH bits of various sizes. Can be used on medium hard rock formations.
GF20Q	6	14.95	90.3	细 Fine	2600	高耐磨性和韧性，适用于各种规格的螺纹钎头和潜孔钻用齿，岩层为中硬岩层。 excellent wear resistance and toughness, Suitable for percussion drilling and DTH bits of various sizes. Can be used on medium hard rock formations.
GF25D	7.8	14.75	89.2	中 Moderate	2800	高韧性，适用于各种规格的冲击钻和潜孔钻用齿，部分用于牙轮钻用齿，岩层为复杂的中硬岩层。 With excellent toughness, The toughness higher than GF20K, Suitable for percussion drilling, DTH bits and partly used in cone bits for drilling complex medium hard rock formations.
GL1002R	10	14.5	89	细 Fine	2900	改进牌号，耐磨性优于GD25A，适用于各种规格的牙轮钻和扩孔钻用齿，岩层为中硬岩层。 upgrade, The wear resistance is better than GD25A Suitable for cone bits and reamer bits of various sizes. Can be used on medium hard rock formations.
GD25A	10	14.5	88.5	中 Moderate	2900	耐磨性优于GD25，适用于各种规格的牙轮钻和扩孔钻用齿，岩层为中硬岩层。 The wear resistance is better than GD25 Suitable for cone bits and reamer bits of various sizes. Can be used on medium hard rock formations.
GD25	10	14.5	87.5	粗 Coarse	2850	韧性优于GD25A，适用于各种规格矿用牙轮钻和扩孔钻用齿，岩层为中软、中硬岩层。 The toughness higher than GD25A, Suitable mining tips, cone bits and reamer bits of various sizes. Can be used on soft and medium hard rock formations.
GD30A	11	14.4	87.7	中 Moderate	2900	耐磨性优于GD30，适用于较大规格的牙轮钻和扩孔钻用齿，岩层为中硬岩层。 The wear resistance is better than GD30, Suitable for big size cone bits and reamer bits. Can be used on medium hard rock formations.
GD30	11	14.4	87	粗 Coarse	2800	韧性优于GD30A，适用于各种规格矿用牙轮钻和扩孔钻用齿，岩层为中软、中硬岩层。 The toughness higher than GD30A, Suitable mining tips, cone bits and reamer bits of various sizes. Can be used on soft and medium hard rock formations.

矿山开采用齿齿形 Shape of Inserts

### 球形齿

Dome Inserts

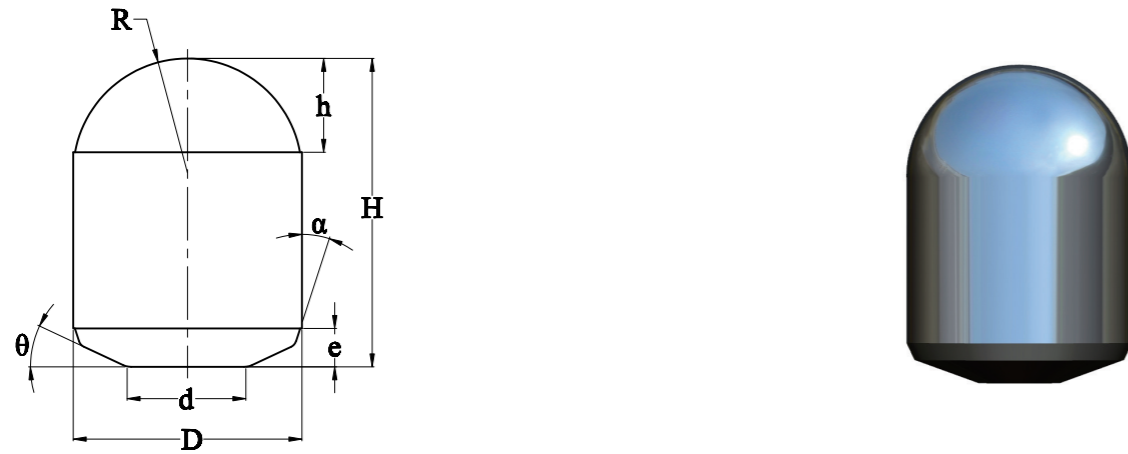

型号 Type	D		H	h	R	e	α	θ
	精品尺寸 Finished Diameter	毛坯尺寸 Blank Diameter						
SQ20810	8.030	8.03 <sup>+0.4</sup> / <sub>+0.2</sub>	10.85	2.60	4.4	1.50	20°	20°
SQ20913	9.040	9.04 <sup>+0.4</sup> / <sub>+0.2</sub>	13.00	3.40	4.7	1.80	20°	24°
SQ21013	10.045	10.05 <sup>+0.4</sup> / <sub>+0.2</sub>	13.50	3.42	5.4	1.90	20°	24°
SQ21115	11.130	11.13 <sup>+0.5</sup> / <sub>+0.2</sub>	15.50	4.51	5.7	2.15	25°	25°
SQ21216	12.045	12.05 <sup>+0.5</sup> / <sub>+0.2</sub>	16.00	4.73	6.2	2.35	20°	24°
SQ21319	13.045	13.05 <sup>+0.5</sup> / <sub>+0.2</sub>	19.00	5.17	6.7	2.45	20°	24°
SQ21420	14.050	14.05 <sup>+0.5</sup> / <sub>+0.2</sub>	20.00	5.90	7.2	2.75	25°	20°
SQ21522	15.950	15.95 <sup>+0.5</sup> / <sub>+0.2</sub>	22.25	5.76	8.4	2.65	15°	15°
SQ21623	16.150	16.15 <sup>+0.5</sup> / <sub>+0.2</sub>	23.00	6.75	8.2	3.00	25°	20°
SQ21823	18.100	18.10 <sup>+0.6</sup> / <sub>+0.2</sub>	23.00	7.55	9.2	3.30	25°	20°
SQ21925	19.070	19.07 <sup>+0.6</sup> / <sub>+0.2</sub>	25.50	8.00	9.7	3.60	25°	20°
SQ22029	20.010	20.01 <sup>+0.6</sup> / <sub>+0.2</sub>	29.00	8.20	10.3	3.70	25°	20°

注：可按客户要求规格生产。  
Note: Can be customized according to customer's requirements.

### 锥形齿

Conical Inserts

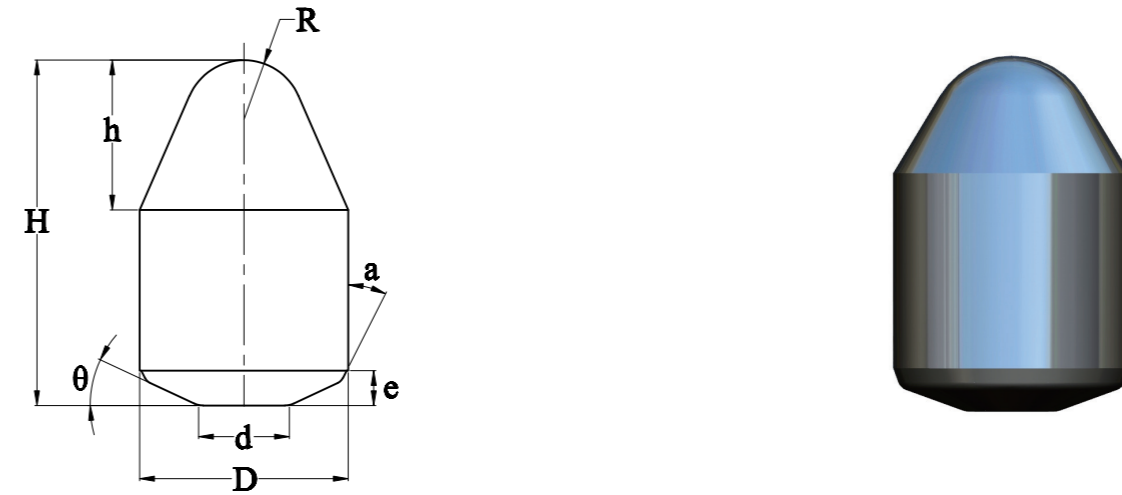

型号 Type	D		H	h	R	e	α	θ
	精品尺寸 Finished Diameter	毛坯尺寸 Blank Diameter						
SZ20710	7.020	7.02 <sup>+0.4</sup> / <sub>+0.2</sub>	10.60	3.50	2.5	1.30	20°	20°
SZ20811	8.020	8.02 <sup>+0.4</sup> / <sub>+0.2</sub>	11.50	4.05	3.0	1.50	20°	20°
SZ20912	9.020	9.02 <sup>+0.4</sup> / <sub>+0.2</sub>	12.60	4.55	3.0	1.60	20°	20°
SZ21014	10.040	10.04 <sup>+0.4</sup> / <sub>+0.2</sub>	14.25	6.15	2.0	1.87	21°	24°
SZ21117	11.040	11.04 <sup>+0.5</sup> / <sub>+0.2</sub>	17.90	6.51	2.5	2.17	21°	24°
SZ21319	13.010	13.01 <sup>+0.5</sup> / <sub>+0.2</sub>	19.90	8.00	4.0	1.95	25°	20°
SZ21522	15.010	15.01 <sup>+0.5</sup> / <sub>+0.2</sub>	22.00	9.05	5.0	2.50	25°	20°
SZ22028	20.690	20.69 <sup>+0.6</sup> / <sub>+0.2</sub>	28.25	10.92	7.9	3.30	15°	20°
SZ22342	23.925	23.93 <sup>+0.6</sup> / <sub>+0.2</sub>	42.70	18.45	7.0	4.05	15°	20°
SZ22844	28.600	28.60 <sup>+0.6</sup> / <sub>+0.2</sub>	44.40	22.25	7.6	4.05	15°	20°

注：可按客户要求规格生产。  
Note: Can be customized according to customer's requirements.



### 弹形齿

Parabolic Inserts

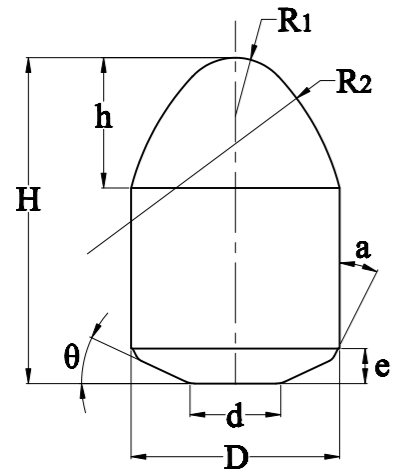

型号 Type	D		H	h	R1	R2	α	θ
	精品尺寸 Finished Diameter	毛坯尺寸 Blank Diameter						
SD20610	6.010	6.01 <sup>+0.4</sup> / <sub>+0.2</sub>	10.20	3.40	1.8	4.0	20°	20°
SD20709	7.050	7.05 <sup>+0.4</sup> / <sub>+0.2</sub>	9.80	3.90	1.9	8.5	25°	20°
SD20811	8.050	8.05 <sup>+0.4</sup> / <sub>+0.2</sub>	11.10	4.45	2.2	9.8	25°	20°
SD20911	9.100	9.10 <sup>+0.4</sup> / <sub>+0.2</sub>	11.45	5.00	2.4	11.0	25°	20°
SD21013	10.050	10.05 <sup>+0.4</sup> / <sub>+0.2</sub>	13.50	5.50	3.0	12.0	25°	20°
SD21118	11.045	11.05 <sup>+0.5</sup> / <sub>+0.2</sub>	18.00	6.80	3.0	12.0	21°	24°
SD21219	12.010	12.01 <sup>+0.5</sup> / <sub>+0.2</sub>	19.00	7.00	3.2	13.0	25°	20°
SD21320	13.010	13.01 <sup>+0.5</sup> / <sub>+0.2</sub>	20.00	7.20	3.3	15.5	25°	20°
SD21422	14.010	14.01 <sup>+0.5</sup> / <sub>+0.2</sub>	22.00	7.70	3.5	16.7	25°	20°
SD21626	16.010	16.01 <sup>+0.6</sup> / <sub>+0.2</sub>	26.00	11.00	4.7	44.5	25°	20°

注：可按客户要求规格生产。  
Note: Can be customized according to customer's requirements.

### 边楔齿

Side Wedged Inserts

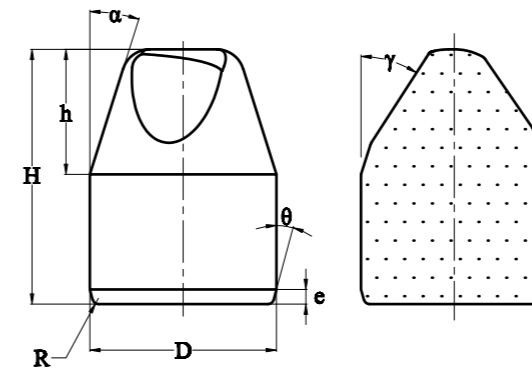

型号 Type	D		H	h	α	γ	θ	e
	精品尺寸 Finished Diameter	毛坯尺寸 Blank Diameter						
SB21115	11.070	11.07 <sup>+0.4</sup> / <sub>+0.2</sub>	15.30	5.30	20°	30°	15°	1.20
SB21317	13.070	13.07 <sup>+0.4</sup> / <sub>+0.2</sub>	17.50	6.50	20°	32°	15°	1.20
SB21419	14.335	14.34 <sup>+0.4</sup> / <sub>+0.2</sub>	19.85	9.50	20°	29°	15°	1.25
SB21521	15.950	15.95 <sup>+0.5</sup> / <sub>+0.2</sub>	21.80	10.70	17.5°	32.9°	15°	1.25
SB21931	19.125	19.13 <sup>+0.5</sup> / <sub>+0.2</sub>	31.90	15.25	15°	29°	15°	1.90
SB22026	20.070	20.07 <sup>+0.5</sup> / <sub>+0.2</sub>	26.00	10.00	22°	36°	15°	1.70
SB22231	22.070	22.07 <sup>+0.5</sup> / <sub>+0.2</sub>	31.00	13.00	20°	33°	15°	1.70

注：可按客户要求规格生产。  
Note: Can be customized according to customer's requirements.

### 楔形齿

Chisel Inserts

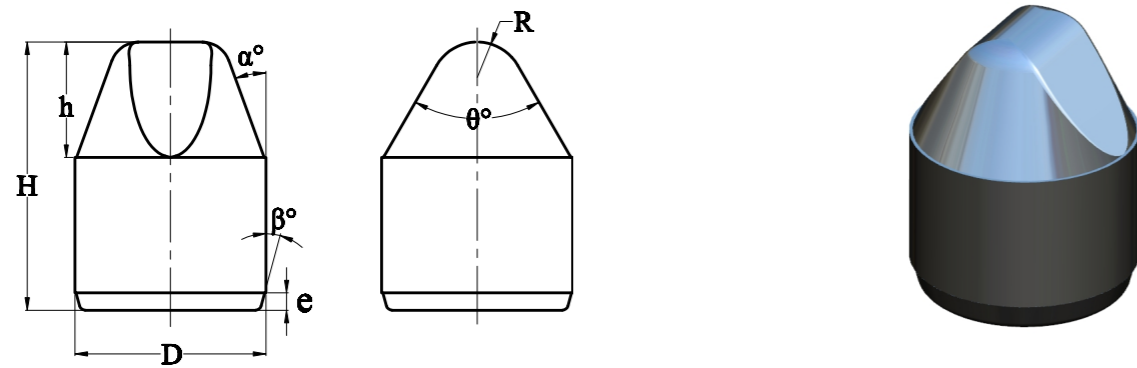

型号 Type	D		H	h	R1	R2	α	θ
	精品尺寸 Finished Diameter	毛坯尺寸 Blank Diameter						
SX10607	6.430	6.43 <sup>+0.4</sup> / <sub>+0.2</sub>	7.50	3.00	22°	80°	1.5	22°
SX10810	8.035	8.04 <sup>+0.4</sup> / <sub>+0.2</sub>	10.55	5.23	25°	59°	2.0	15°
SX10912	9.635	9.64 <sup>+0.4</sup> / <sub>+0.2</sub>	12.70	6.35	19.5°	63.5°	1.9	15°
SX11014	10.070	10.07 <sup>+0.4</sup> / <sub>+0.2</sub>	14.00	6.00	15°	80°	1.0	15°
SX11112	11.070	11.07 <sup>+0.5</sup> / <sub>+0.2</sub>	12.40	4.40	15°	91.5°	2.5	15°
SX11215	12.070	12.07 <sup>+0.5</sup> / <sub>+0.2</sub>	15.00	7.00	15°	90°	1.0	15°
SX11316	13.070	13.07 <sup>+0.5</sup> / <sub>+0.2</sub>	16.50	7.50	20°	62.7°	3.5	15°
SX11420	14.070	14.07 <sup>+0.5</sup> / <sub>+0.2</sub>	20.10	9.10	20°	58°	4.2	15°
SX11520	15.950	15.95 <sup>+0.6</sup> / <sub>+0.2</sub>	20.00	9.70	18°	72.5°	3.2	15°
SX11625	16.070	16.07 <sup>+0.6</sup> / <sub>+0.2</sub>	25.00	12.00	13°	52°	3.5	15°
SX11926	19.125	19.13 <sup>+0.6</sup> / <sub>+0.2</sub>	26.65	12.40	22°	64°	4.2	15°
SX12233	22.300	22.30 <sup>+0.6</sup> / <sub>+0.2</sub>	33.00	16.50	18°	55°	4.8	15°
SX12550	25.470	25.47 <sup>+0.6</sup> / <sub>+0.2</sub>	50.80	25.40	11°	47°	2.8	15°

注：可按客户要求规格生产。  
Note: Can be customized according to customer's requirements.

### 平顶齿

Flat Inserts

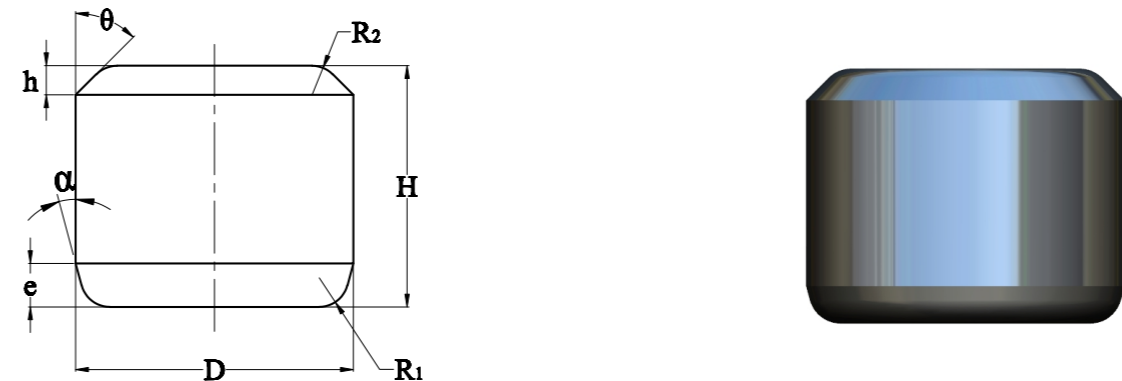

型号 Type	D		H	h	θ	e	α
	精品尺寸 Finished Diameter	毛坯尺寸 Blank Diameter					
SP10404	4.860	4.86 <sup>+0.4</sup> / <sub>+0.2</sub>	4.20	0.50	45°	0.75	15°
SP10604	6.070	6.07 <sup>+0.4</sup> / <sub>+0.2</sub>	4.80	0.90	45°	1.00	15°
SP10805	8.017	8.02 <sup>+0.4</sup> / <sub>+0.2</sub>	5.00	0.50	45°	1.00	15°
SP10908	9.615	9.62 <sup>+0.4</sup> / <sub>+0.2</sub>	8.03	0.50	45°	1.27	15°
SP11008	10.070	10.07 <sup>+0.5</sup> / <sub>+0.2</sub>	8.00	1.20	45°	1.20	15°
SP11108	11.190	11.19 <sup>+0.5</sup> / <sub>+0.2</sub>	8.74	1.20	45°	1.15	15°
SP11210	12.070	12.07 <sup>+0.5</sup> / <sub>+0.2</sub>	10.00	1.20	45°	1.20	15°
SP11317	13.600	13.60 <sup>+0.5</sup> / <sub>+0.2</sub>	17.85	1.65	60°	1.65	60°
SP11510	15.950	15.95 <sup>+0.6</sup> / <sub>+0.2</sub>	10.55	0.50	45°	1.25	15°
SP11625	16.700	16.70 <sup>+0.6</sup> / <sub>+0.2</sub>	25.00	2.80	60°	2.80	60°
SP12519	25.475	25.47 <sup>+0.6</sup> / <sub>+0.2</sub>	19.05	0.80	45°	1.90	15°

注：可按客户要求规格生产。  
Note: Can be customized according to customer's requirements.

## 锯形齿

Serrated flat Inserts

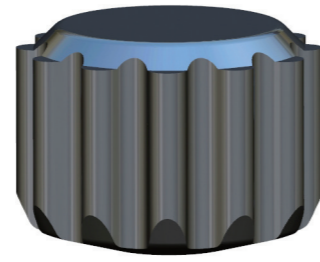
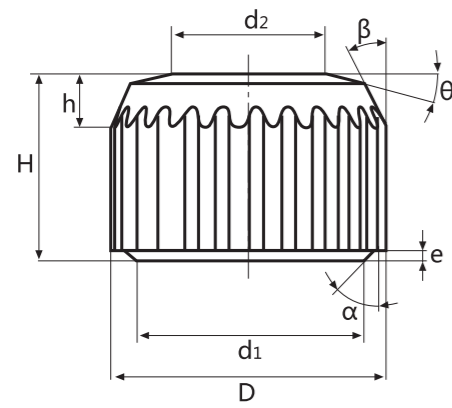

型号 Type	D	H	h	d1	d2	$\alpha$	$\beta$	$\theta$
SU30606	6.55	6.05	1.15	4.80	2.55	45°	25°	15°
SU30807	8.17	7.45	1.90	6.10	3.80	45°	25°	15°
SU30908	9.75	8.03	1.90	7.37	5.30	45°	25°	15°
SU31208	12.95	8.85	2.55	10.87	7.15	45°	25°	15°
SU31409	14.95	9.53	3.60	12.70	7.15	45°	25°	15°

注：可按客户要求规格生产。  
Note: Can be customized according to customer's requirements.



油田开采用齿  
Inserts for oil & gas

### 油田牙轮钻齿概况

Inserts for Oilfield & Gas

相关齿形 Shapes	常用牌号 Grade	齿形代码 Shape Code	应用工况 The Application Conditions
边楔齿 Wedge Crested Chisel Insert	GD25A、GD30F	SB	适用于中硬岩f10-f15层的外排齿等 Medium Hard Rock Formation F10-F15
平顶齿 Flat Insert	GF20D、GF25D	SP	保径齿 Gauge Insert
球形齿 Ovoid Insert	GF20D、GD25A	SQ	适用于极硬f15-f20岩层 Super Hard Rock Formation F15-F20
勺形齿 Scoop insert	GD25、GD60A、GD60C	SS	适用于快速掘进的f5-f10软岩层 High Speed Drilling On Soft Rock Formation F5-F10
锯齿形齿 Serrated Flat Insert	GF20D、GD25A	SU	保径齿，对孔径精度要求较低 Gauge Insert
楔形齿 Chisel Insert	GD25A、GD30F、GD60、GD60A、GD60C	SX	适用于快速掘进的f5-f10软岩层 High Speed Drilling On Soft Rock Formation F5-F10
锥形齿 Conical Insert	GD25、GD25A、GD30F、GD60A	SZ	适用于中硬f10-f15岩层 Medium Hard Rock Formation F10-F15

### 油田牙轮钻齿牌号及应用领域

Grades & Applications

牌号 Grade	钴含量 Cobalt (%)	密度Den. (g/cm <sup>3</sup> )	硬度 Hardness HRA	晶粒度 Grain Size	抗弯强度 TRS	牌号描述 Grades Descriptions
GF20D	6	14.95	90.5	细 Fine	2600	具有很好的耐磨性，适用于各种牙轮钻头保径齿。 With excellent wear resistance, suitable for cone bits of various sizes.Gauge inserts
GF25D	7.8	14.75	89.2	中 Moderate	2800	具有良好的耐磨性和韧性，适用于各种牙轮钻头保径齿、中硬岩层切削齿。 With excellent wear resistance, suitable for cone bits of various sizes.Gauge inserts
GK40A	9	14.65	89.5	细 Fine	2800	具有较好的耐磨性和韧性，适用于牙轮钻用齿，岩层为中硬岩层。 With excellent wear resistance and good toughness, Suitable for cone bits of various sizes. Can be used on medium hard rock formations.
GD22B	9	14.6	88.8	中 Moderate	3000	适用于中韧性的需求的石油开采作业。 Suitable for oil drilling. Satisfy the needs of medium toughness.
GD25A	10	14.5	88.5	中 Moderate	2900	耐磨性优于GD25，适用于各种规格的牙轮钻和扩孔钻用齿，岩层为中硬岩层。 The wear resistance is better than GD25 Suitable for cone bits and reamer bits of various sizes. Can be used on medium hard rock formations.
GD25	10	14.5	87.5	粗 Coarse	2850	韧性优于GD25A，适用于各种规格的牙轮钻头齿，岩层为中硬岩层。 The toughness is higher than GD25A,suitable for cone bits of various sizes,medium hard rock
GD30F	11	14.35	88.2	中 Moderate	3000	韧性优于GD25A，适用于中韧性需求的矿用、油用牙轮钻头齿，岩层为中硬岩层。 The toughness is higher than GD25A, Suitable for cone Bits for mining and oilfield, can be used on medium hard rock formations satisfy the needs of medium toughness.
GD30	11	14.4	86.8	粗 Coarse	2800	韧性优于GD30F，适用于各种规格的牙轮钻头齿，岩层为中硬岩层。 The toughness is higher than GD30F,suitable for cone bits of various sizes,medium hard rock
GD40	12	14.3	86.8	粗 Coarse	2800	具有良好的韧性，适用于各种规格牙轮钻头齿，岩层为中软岩层。 With excellent toughness. suitable for cone bitss of various sizes,medium soft rock
GD40A	14	14.15	87.4	中 Moderate	2900	具有良好的韧性，适用于油用牙轮钻头齿，岩层为中软岩层。 With excellent toughness, suitable for cone bits for oilfield, Can be used on soft rock formations.
GD60	15	14	85.8	粗 Coarse	2800	具有良好的韧性，适用于快速掘进、中长露齿的牙轮钻头齿，岩层为中软岩层。 With excellent toughness suitable for high speed drilling and cone bits
GD60A	16	13.95	86.5	中 Moderate	2900	具有良好的韧性，适用于高韧性、中软岩层的牙轮钻头齿。 With excellent toughness, suitable for cone bits can be used on soft rock formations, satisfy the needs of high toughness.
GD60C	16	13.95	84.7	超粗 Ultra Coarse	2700	具有良好的韧性，适用于快速掘进的软岩层类、中长露齿高度的油用牙轮钻头。With excellent toughness Suitable for high speed oilfield drilling on soft rock formations.

油田牙轮钻齿齿形 Shape of Inserts for Oilfield & Gas

### 球形齿

Dome Inserts

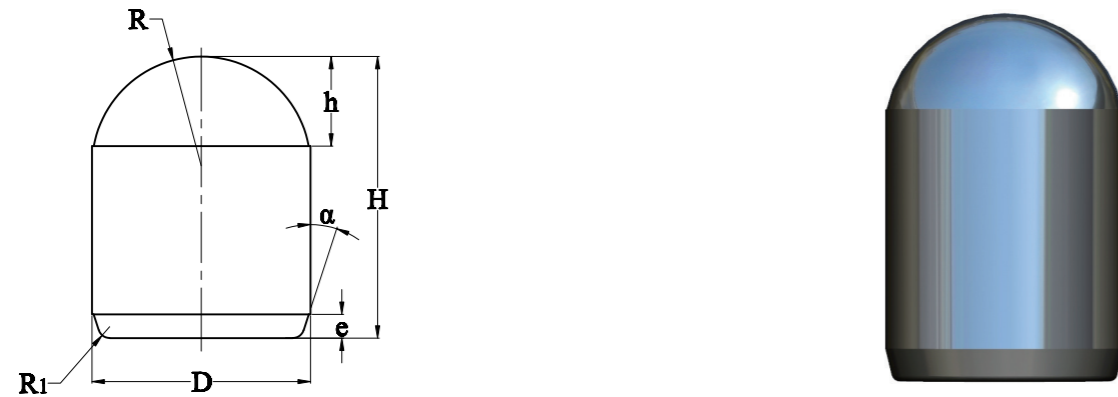

型号 Type	D		H	h	R	e	α
	精品尺寸 Finished Diameter	毛坯尺寸 Blank Diameter					
SQ10405	4.860	4.86 <sup>+0.4</sup> / <sub>+0.2</sub>	5.10	0.95	3.6	0.75	15°
SQ10605	6.468	6.47 <sup>+0.4</sup> / <sub>+0.2</sub>	5.25	0.70	7.7	1.25	15°
SQ10806	8.017	8.02 <sup>+0.4</sup> / <sub>+0.2</sub>	6.75	1.40	6.4	1.25	15°
SQ10909	9.585	9.59 <sup>+0.4</sup> / <sub>+0.2</sub>	9.53	3.36	5.1	1.50	18°
SQ11010	10.070	10.07 <sup>+0.5</sup> / <sub>+0.2</sub>	10.20	3.15	5.6	1.50	15°
SQ11108	11.190	11.19 <sup>+0.5</sup> / <sub>+0.2</sub>	8.89	1.42	11.7	1.25	15°
SQ11209	12.790	12.79 <sup>+0.5</sup> / <sub>+0.2</sub>	9.20	2.05	10.9	1.25	15°
SQ11319	13.700	13.70 <sup>+0.5</sup> / <sub>+0.2</sub>	19.35	5.56	7.0	2.00	15°
SQ11422	14.300	14.30 <sup>+0.5</sup> / <sub>+0.2</sub>	22.35	5.70	7.3	2.00	15°
SQ11520	15.950	15.95 <sup>+0.6</sup> / <sub>+0.2</sub>	20.85	7.20	8.0	1.25	15°
SQ11625	16.700	16.70 <sup>+0.6</sup> / <sub>+0.2</sub>	25.40	6.55	8.6	2.00	15°
SQ11726	17.000	17.00 <sup>+0.6</sup> / <sub>+0.2</sub>	26.00	6.52	8.8	2.00	18°
SQ11825	18.000	18.00 <sup>+0.6</sup> / <sub>+0.2</sub>	25.00	7.29	9.2	2.00	18°
SQ11913	19.140	19.14 <sup>+0.6</sup> / <sub>+0.2</sub>	13.23	3.25	16.4	1.90	15°
SQ12528	25.475	25.48 <sup>+0.6</sup> / <sub>+0.2</sub>	28.37	10.59	13.0	1.90	15°

注：可按客户要求规格生产。  
Note: Can be customized according to customer's requirements.

### 锥形齿

Conical Inserts

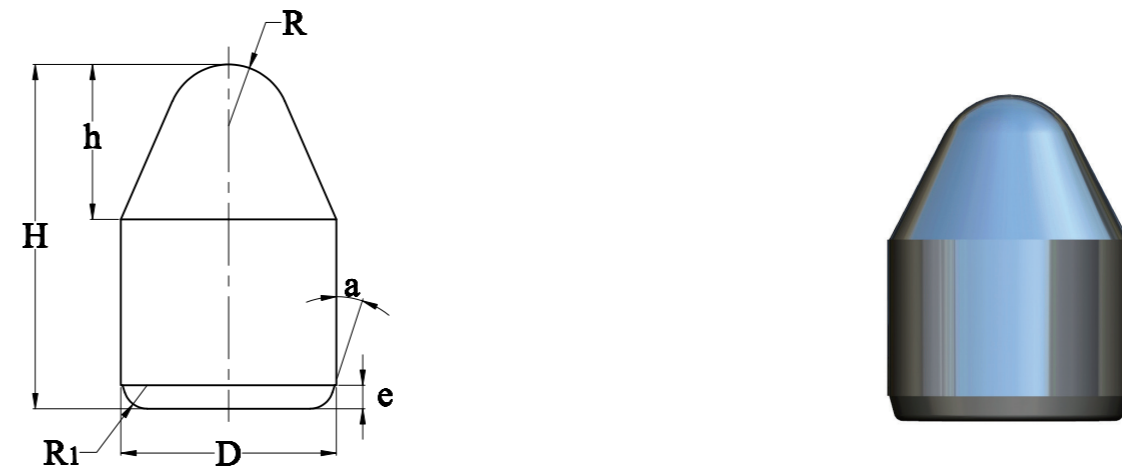

型号 Type	D		H	h	R	e	α
	精品尺寸 Finished Diameter	毛坯尺寸 Blank Diameter					
SZ10507	5.000	5.00 <sup>+0.4</sup> / <sub>+0.2</sub>	7.20	3.80	0.5	0.50	45°
SZ10809	8.035	8.04 <sup>+0.4</sup> / <sub>+0.2</sub>	9.40	4.05	2.9	1.25	15°
SZ10910	9.070	9.07 <sup>+0.4</sup> / <sub>+0.2</sub>	10.50	4.00	4.3	1.00	15°
SZ11012	10.070	10.07 <sup>+0.5</sup> / <sub>+0.2</sub>	12.90	5.30	4.0	1.30	15°
SZ11115	11.070	11.07 <sup>+0.5</sup> / <sub>+0.2</sub>	15.50	5.50	4.5	1.30	15°
SZ11214	12.070	12.07 <sup>+0.5</sup> / <sub>+0.2</sub>	14.50	6.00	5.3	1.30	15°
SZ11317	13.070	13.07 <sup>+0.5</sup> / <sub>+0.2</sub>	17.10	6.75	4.4	1.30	15°
SZ11420	14.335	14.34 <sup>+0.5</sup> / <sub>+0.2</sub>	20.60	9.50	4.3	1.25	15°
SZ11520	15.950	15.95 <sup>+0.6</sup> / <sub>+0.2</sub>	20.30	9.20	6.6	1.25	15°
SZ11826	18.200	18.20 <sup>+0.6</sup> / <sub>+0.2</sub>	26.50	10.70	2.0	1.00	45°
SZ11926	19.125	19.13 <sup>+0.6</sup> / <sub>+0.2</sub>	26.65	12.40	5.2	1.90	15°

注：可按客户要求规格生产。  
Note: Can be customized according to customer's requirements.

### 边楔齿

Side Wedged Inserts

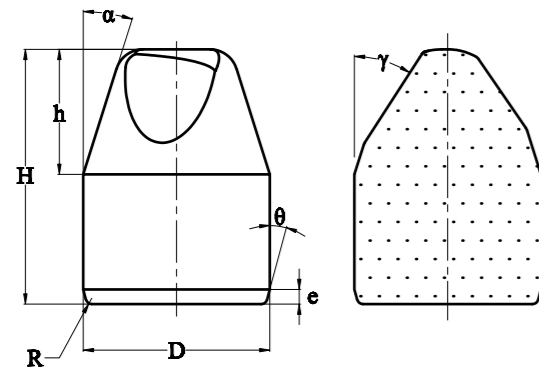

型号 Type	D		H	h	α	γ	θ	e
	精品尺寸 Finished Diameter	毛坯尺寸 Blank Diameter						
SB21115	11.070	11.07 <sup>+0.4</sup> / <sub>+0.2</sub>	15.30	5.30	20°	30°	15°	1.20
SB21317	13.070	13.07 <sup>+0.4</sup> / <sub>+0.2</sub>	17.50	6.50	20°	32°	15°	1.20
SB21419	14.335	14.34 <sup>+0.4</sup> / <sub>+0.2</sub>	19.85	9.50	20°	29°	15°	1.25
SB21521	15.950	15.95 <sup>+0.5</sup> / <sub>+0.2</sub>	21.80	10.70	17.5°	32.9°	15°	1.25
SB21931	19.125	19.13 <sup>+0.5</sup> / <sub>+0.2</sub>	31.90	15.25	15°	29°	15°	1.90
SB22026	20.070	20.07 <sup>+0.5</sup> / <sub>+0.2</sub>	26.00	10.00	22°	36°	15°	1.70
SB22231	22.070	22.07 <sup>+0.5</sup> / <sub>+0.2</sub>	31.00	13.00	20°	33°	15°	1.70

注：可按客户要求规格生产。  
Note: Can be customized according to customer's requirements.

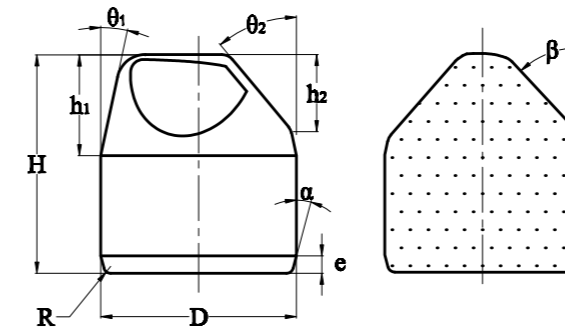

型号 Type	D		H	h1	θ1	θ2	β	e
	精品尺寸 Finished Diameter	毛坯尺寸 Blank Diameter						
SB41416	14.335	14.34 <sup>+0.5</sup> / <sub>+0.2</sub>	16.05	7.42	12°	40°	41°	1.25
SB41522	15.950	15.95 <sup>+0.5</sup> / <sub>+0.2</sub>	22.20	9.50	15°	40°	39°	1.25
SB41620	16.070	16.07 <sup>+0.6</sup> / <sub>+0.2</sub>	20.00	8.00	20°	39°	36°	1.70
SB42027	20.070	20.07 <sup>+0.6</sup> / <sub>+0.2</sub>	27.00	12.00	20°	38°	33°	1.70

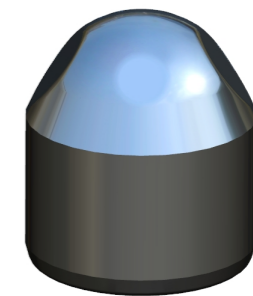
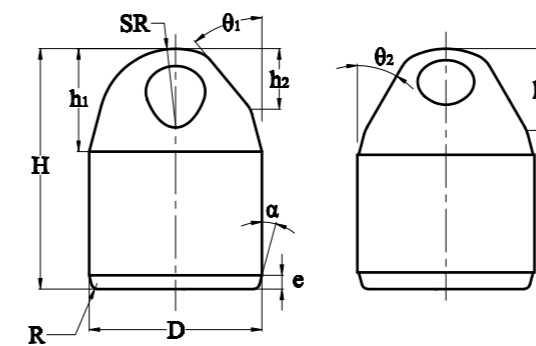

型号 Type	D		H	h1	SR	θ1	θ2	e
	精品尺寸 Finished Diameter	毛坯尺寸 Blank Diameter						
SB61115	11.210	11.21 <sup>+0.5</sup> / <sub>+0.2</sub>	15.25	5.72	5.0	41°	42°	1.25
SB61216	12.810	12.81 <sup>+0.5</sup> / <sub>+0.2</sub>	16.65	7.10	5.9	42°	42°	1.25
SB61416	14.335	14.34 <sup>+0.5</sup> / <sub>+0.2</sub>	16.05	7.40	6.9	40.5°	33°	1.25
SB61522	15.950	15.95 <sup>+0.6</sup> / <sub>+0.2</sub>	22.20	9.50	7.1	39.5°	30°	1.25
SB62231	22.300	22.30 <sup>+0.6</sup> / <sub>+0.2</sub>	31.80	12.70	10.5	40°	29°	1.90

注：可按客户要求规格生产。  
Note: Can be customized according to customer's requirements.

### 楔形齿

Chisel Inserts

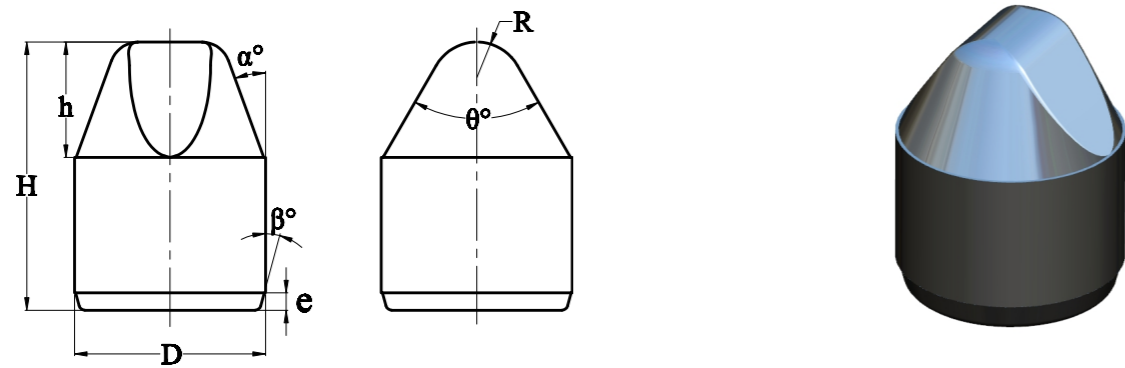

型号 Type	D		H	h1	θ1	θ2	β	e
	精品尺寸 Finished Diameter	毛坯尺寸 Blank Diameter						
SX10607	6.430	6.43 <sup>+0.4</sup> / <sub>+0.2</sub>	7.50	3.00	22°	80°	1.5	22°
SX10810	8.035	8.04 <sup>+0.4</sup> / <sub>+0.2</sub>	10.55	5.23	25°	59°	2.0	15°
SX10912	9.635	9.64 <sup>+0.4</sup> / <sub>+0.2</sub>	12.70	6.35	19.5°	63.5°	1.9	15°
SX11014	10.070	10.07 <sup>+0.4</sup> / <sub>+0.2</sub>	14.00	6.00	15°	80°	1.0	15°
SX11112	11.070	11.07 <sup>+0.5</sup> / <sub>+0.2</sub>	12.40	4.40	15°	91.5°	2.5	15°
SX11215	12.070	12.07 <sup>+0.5</sup> / <sub>+0.2</sub>	15.00	7.00	15°	90°	1.0	15°
SX11316	13.070	13.07 <sup>+0.5</sup> / <sub>+0.2</sub>	16.50	7.50	20°	62.7°	3.5	15°
SX11420	14.070	14.07 <sup>+0.5</sup> / <sub>+0.2</sub>	20.10	9.10	20°	58°	4.2	15°
SX11520	15.950	15.95 <sup>+0.6</sup> / <sub>+0.2</sub>	20.00	9.70	18°	72.5°	3.2	15°
SX11625	16.070	16.07 <sup>+0.6</sup> / <sub>+0.2</sub>	25.00	12.00	13°	52°	3.5	15°
SX11926	19.125	19.13 <sup>+0.6</sup> / <sub>+0.2</sub>	26.65	12.40	22°	64°	4.2	15°
SX12233	22.300	22.30 <sup>+0.6</sup> / <sub>+0.2</sub>	33.00	16.50	18°	55°	4.8	15°
SX12550	25.470	25.47 <sup>+0.6</sup> / <sub>+0.2</sub>	50.80	25.40	11°	47°	2.8	15°

注：可按客户要求规格生产。  
Note: Can be customized according to customer's requirements.

### 勺形齿

Scoop Inserts

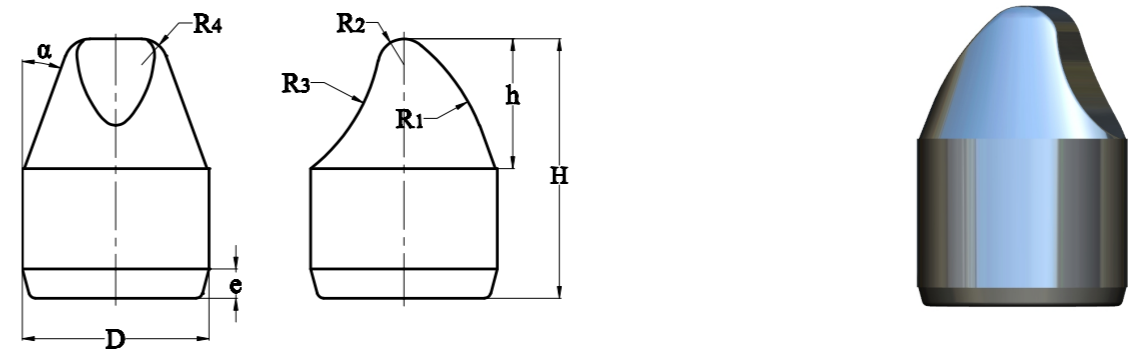

型号 Type	D		H	h	α	R1	R2	R3
	精品尺寸 Finished Diameter	毛坯尺寸 Blank Diameter						
SS10911	9.070	9.07 <sup>+0.4</sup> / <sub>+0.2</sub>	11.10	4.40	20°	10.0	3.0	20.0
SS11015	10.070	10.07 <sup>+0.5</sup> / <sub>+0.2</sub>	15.20	5.20	25°	20.0	3.0	12.0
SS11116	11.070	11.07 <sup>+0.5</sup> / <sub>+0.2</sub>	16.80	6.30	25°	24.0	3.0	15.0
SS11217	12.070	12.07 <sup>+0.5</sup> / <sub>+0.2</sub>	17.00	6.50	25°	20.0	3.0	20.0
SS11318	13.070	13.07 <sup>+0.5</sup> / <sub>+0.2</sub>	18.20	7.20	25°	6.0	3.6	28.0
SS11523	15.945	15.95 <sup>+0.6</sup> / <sub>+0.2</sub>	23.00	9.95	20°	16.2	3.6	18.9
SS11929	19.135	19.14 <sup>+0.6</sup> / <sub>+0.2</sub>	29.40	11.90	20°	16.1	2.8	22.5
SS12235	22.310	22.31 <sup>+0.6</sup> / <sub>+0.2</sub>	35.30	15.90	15°	24.2	2.8	27.9

注：可按客户要求规格生产。  
Note: Can be customized according to customer's requirements.

# 平顶齿

Flat Inserts

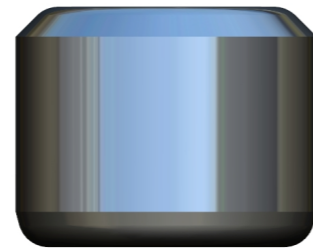
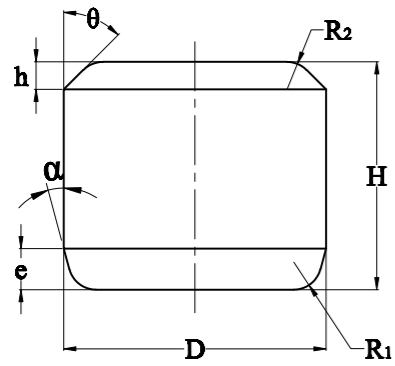

型号 Type	D		H	h	θ	e	α
	精品尺寸 Finished Diameter	毛坯尺寸 Blank Diameter					
SP10404	4.860	4.86 <sup>+0.4</sup> / <sub>+0.2</sub>	4.20	0.50	45°	0.75	15°
SP10604	6.070	6.07 <sup>+0.4</sup> / <sub>+0.2</sub>	4.80	0.90	45°	1.00	15°
SP10805	8.017	8.02 <sup>+0.4</sup> / <sub>+0.2</sub>	5.00	0.50	45°	1.00	15°
SP10908	9.615	9.62 <sup>+0.4</sup> / <sub>+0.2</sub>	8.03	0.50	45°	1.27	15°
SP11008	10.070	10.07 <sup>+0.5</sup> / <sub>+0.2</sub>	8.00	1.20	45°	1.20	15°
SP11108	11.190	11.19 <sup>+0.5</sup> / <sub>+0.2</sub>	8.74	1.20	45°	1.15	15°
SP11210	12.070	12.07 <sup>+0.5</sup> / <sub>+0.2</sub>	10.00	1.20	45°	1.20	15°
SP11317	13.600	13.60 <sup>+0.5</sup> / <sub>+0.2</sub>	17.85	1.65	60°	1.65	60°
SP11510	15.950	15.95 <sup>+0.6</sup> / <sub>+0.2</sub>	10.55	0.50	45°	1.25	15°
SP11625	16.700	16.70 <sup>+0.6</sup> / <sub>+0.2</sub>	25.00	2.80	60°	2.80	60°
SP12519	25.475	25.47 <sup>+0.6</sup> / <sub>+0.2</sub>	19.05	0.80	45°	1.90	15°

注：可按客户要求规格生产。  
Note: Can be customized according to customer's requirements.

煤矿开采用齿  
Inserts for coal mine



### 煤炭采掘用齿概况

Inserts For Mining

钻头类别 Classify By Bit	常用牌号 Grade	相关齿形 Shapes	齿形代码 Shape Code	应用工况 The Application Conditions
煤矿截齿 Coal Cutting Drilling Tips	GF40	片状截齿 Flake Insert	M	适用于软岩掘进 Weak Rock Formations
	GD20A、GD20S、 GD30C、GL0612C、 GL0809C、GL0812C	柱状截齿 Columnar Insert	SD、SZ	适用于硬岩、中硬岩f10-f15掘进、 复杂煤层开采 F10-F15 Medium Hard Rock Formation, Side Tips
	GD20S、GD30C GL0612C、GL0809C、 GL0812C	异形截齿 Special-Shaped Insert	SW	适用于f05-f10中软岩掘进、各类煤 层开采 Medium Soft Rock Formations F05-F10

### 煤炭采掘用齿牌号及应用领域

Grades & Applications

牌号 Grade	钴含量 Cobalt (%)	密度Den. (g/cm <sup>3</sup> )	硬度 Hardness HRA	晶粒度 Grain Size	抗弯强度 TRS	牌号描述 Grades Descriptions
GL0612C	6.5	14.9	86	极粗粒度 Extrme-coarse	1800	改进牌号，具有优越的冲击性能及抗热疲劳性能，适用于煤矿及其他隧道掘进。 upgrade, With excellent impact resistance and thermal fatigue resistance, Suitable for coal mine drilling
GL0809C	8	14.7	85.8	特粗 Ultra Coarse	1800	改进牌号，具有优越的冲击性能及抗热疲劳性能，适用于煤矿及其他隧道掘进。 upgrade, With excellent impact resistance and thermal fatigue resistance, Suitable for coal mine drilling
GL0812C	8	14.7	85.4	极粗粒度 Extrme-coarse	1700	改进牌号，具有优越的冲击性能及抗热疲劳性能，适用于硬岩煤矿及其他隧道掘进。 upgrade, With excellent impact resistance and thermal fatigue resistance, Suitable for coal mine drilling
GD20S	8	14.7	86	特粗 Ultra Coarse	2000	具有优越的冲击性能及抗热疲劳性能，适用于煤矿掘进、硬岩旋挖齿。 With excellent t impact resistance and thermal fatigue resistance, Suitable for coal mine drilling and hard rock formation rotary drilling.
GD20A	9	14.6	86.5	超粗 Ultra Coarse	2500	具有良好的韧性及抗热疲劳性能，适用于采矿、采煤机用齿。 With excellent toughness and thermal fatigue resistance, Suitable for mining and coal cutting.
GD30C	10	14.45	86	超粗 Ultra Coarse	2400	具有良好的韧性及抗热疲劳性能，适用于采矿、采煤机、掘进机用齿和旋挖机用齿。 With excellent toughness and thermal fatigue resistance, Suitable for mining, coal cutting and rotary drilling.
GF40	12	14.3	89	中 Moderate	3060	适用于单一煤层刨煤机采煤刀片。 Used for single coal plow coal mining blade

煤炭采掘用齿概况 Inserts for Coal Cutting

### 片状截煤齿

Flake Inserts

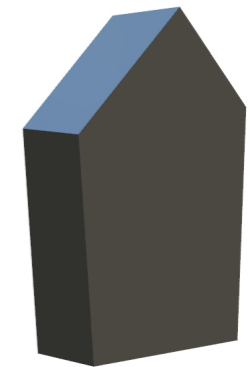
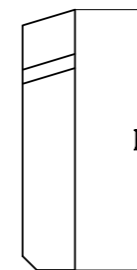
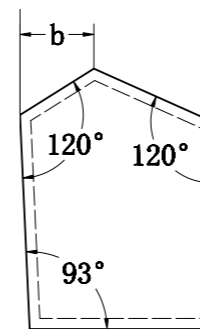

型号 Type	B	H	S	B
M1011R	11	12	2.5	4
M1011L	11	12	2.5	4
M1014R	14	19	3.8	4
M1014L	14	19	3.8	4
M1015R	15	22	3.0	5
M1015L	15	22	3.0	5
M1018R	18	22	6.0	5
M1018L	18	22	6.0	5

注：可按客户要求规格生产。  
Note: Can be customized according to customer's requirements.

## 片状截煤齿

Flake Inserts

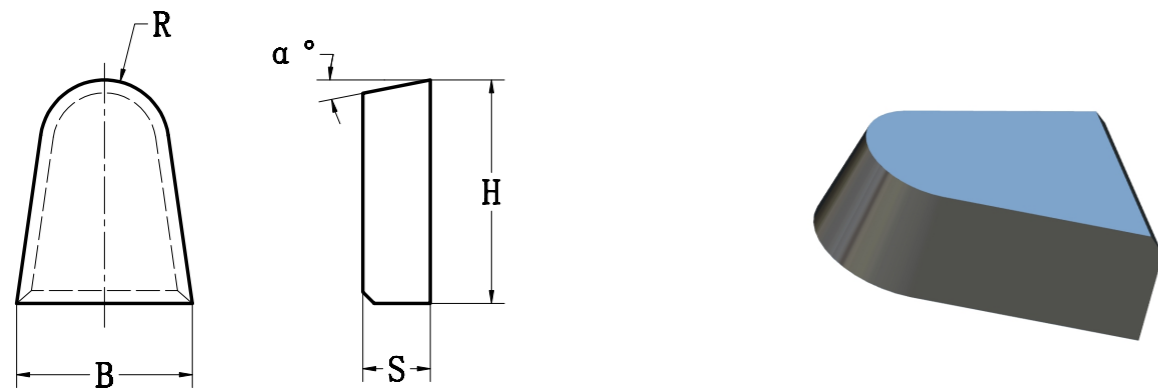

型号 Type	B	H	S	R	a	e
M1216	16	22	7	6	15	1.0
M1220	20	27	8	7	15	1.0
M1222	22	22	7.5	9	10	1.5
M1230	30	35	12	8	8	1.0

注：可按客户要求规格生产。  
Note: Can be customized according to customer's requirements.

## 柱状截煤齿

Columnar Inserts

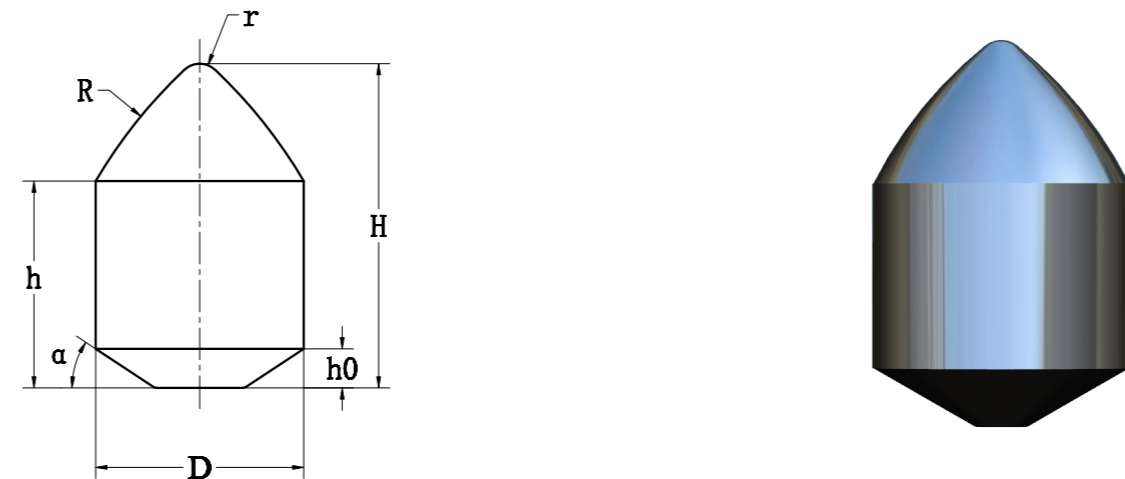

型号 Type	D	H	h	R	r
SD11622	16	22	13	35	1.5
SD11926	19	26	16	26	0.5
SD11944	19	44	34	25	2.0
SD12128	21	28	16	26	2.0
SD12234	22.9	34	21.6	30	2.0
SD12535	25.5	35	21	40	4.0
SD12635	26.5	35	21	40	4.0

注：可按客户要求规格生产。  
Note: Can be customized according to customer's requirements.

### 柱状截煤齿 Columnar Inserts

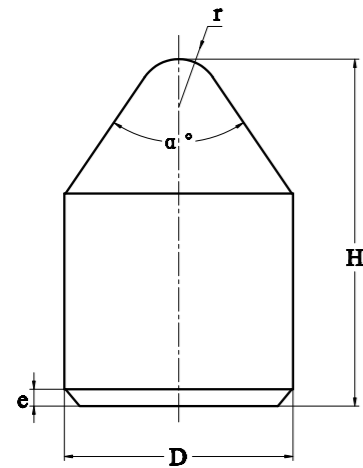

型号 Type	D	H	e	a	e
SZ10916	9	16	1.0	90	1.0
SZ11218	12	18	1.5	82	1.0
SZ11320	13.4	20	4	55	1.4
SZ11933	19	33.8	3.3	90	1.8
SZ82128	21	28	2.0	80	2.1
SZ82539	25	39	3.0	60	5.6

注：可按客户要求规格生产。  
Note: Can be customized according to customer's requirements.

### 蘑菇状截煤齿 Mushroom-Shaped Inserts

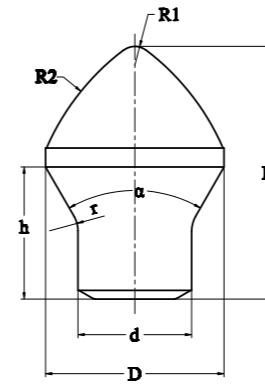

型号 Type	D	d	H	h
SW61622	16.2	10.4	22.4	13.7
SW61728	17.0	11.7	28	15
SW61828	18.9	12.2	28.8	14.1
SW61928	19	12	28	15
SW62132	21.9	14.7	32.9	16.1
SW62434	24.9	17.2	34.2	18.5
SW62538	25	16.8	38	20

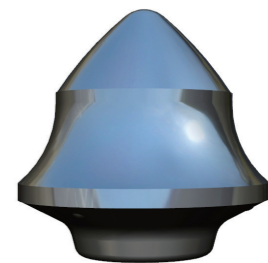
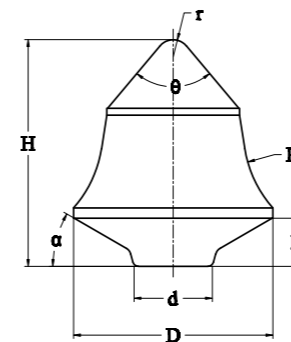

型号 Type	D	d	H	h
SW41616	16.2	7.0	15.5	4.0
SW42423	24.0	13.0	23.6	5.4
SW42933	29.0	11.4	33.0	7.0
SW43336	33.0	19.0	36.0	11

注：可按客户要求规格生产。  
Note: Can be customized according to customer's requirements.

## 异形截煤齿

Special-Shaped Inserts

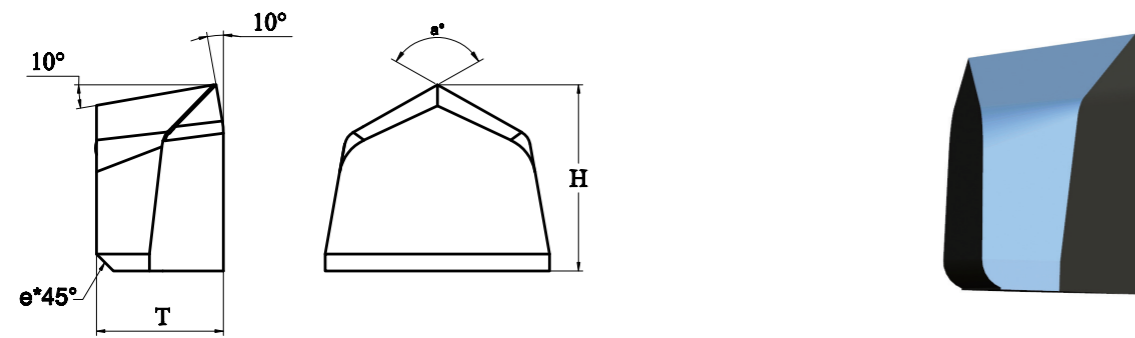

型号 Type	W	T	H	a
M1921	19.1	11.1	21.1	75
M2622	26.5	15.0	22	120
M3825	38.2	25.2	18.1	120

注：可按客户要求规格生产。  
Note: Can be customized according to customer's requirements.



工程建筑用齿  
Inserts for construction

### 工程、建筑用合金齿概况

Inserts for Construction

钻头类别 Classify By Bit	常用牌号 Grade	相关齿形 Shapes	齿形代码 Shape Code	应用工况 The Application Conditions
路面铣刨截齿 Road Plane Milling Tips	GD10、GD10S GL00603M、GL0605M	帽状铣刨齿 Cap-Shaped Insert	SW	用于沥青路面铣刨 Asphalt Road Plane Milling
	GD10 GL00603M	柱状铣刨齿 Columnar Insert	SZ	用于水泥路面铣刨 Cement Road Plane Milling
旋挖截齿 Drill Tips	GD20S、GD30C、 GL0809F、GL0812F	旋挖齿 Rotary Insert	SD	各类工程、建筑掘进 Construction Drilling
截齿 Drill Tips	GF50	地质勘探合金 Geological Prospecting Insrt	T	用于中韧性需求的工程凿岩用齿 Construction Drilling Satisfy The Needs Of Medium Toughness

### 工程、建筑用合金齿牌号

Grades for Construction

牌号 Grade	钴含量 Cobalt (%)	密度Den. (g/cm <sup>3</sup> )	硬度 Hardness HRA	晶粒度 Grain Size	抗弯强度 TRS	牌号描述 Grades Descriptions
GD10	6	14.95	89	中 Moderate	2500	具有良好的韧性及耐磨性，适用于水泥路面拉毛铣刨齿。 With excellent toughness and wear resistance, suitable for cement road plane milling.
GL0603M	6	14.95	88.7	中 Moderate	2500	改进牌号，具有良好的韧性及耐磨性，适用于水泥路面拉毛与铣刨齿。 upgrade, With excellent toughness and wear resistance, suitable for cement road plane milling.
GL0605M	6	14.95	88	粗 Coarse	2200	改进牌号，具有良好的韧性、抗热疲劳性及耐磨性，适用于沥青与混合路面铣刨齿。 upgrade, With excellent toughness and thermal fatigue resistance, Suitable for road plane milling.
GD10S	6	14.95	88	粗 Coarse	2400	具有良好的韧性、抗热疲劳性及耐磨性，适用于采矿类截齿及路面铣刨齿。 With excellent toughness and thermal fatigue esistance, Suitable for road plane milling.
GD20S	8	14.7	86	特粗 Ultra Coarse	1800	具有优越的冲击性能及抗热疲劳性能，适用于煤矿掘进、硬岩旋挖齿。 With excellent impact resistance and thermal fatigue resistance, Suitable for coal mine drilling and hard rock formation rotary drilling.
GL0809F	8	14.7	85.8	超粗 Ultra Coarse	1800	改进牌号，具有优越的冲击性能及抗热疲劳性能，适用于硬岩巷道掘进、硬岩旋挖齿。 upgrade, With excellent impact resistance and thermal fatigue resistance, Suitable for hard rock coal mine drilling and formation rotary drilling.
GL0812F	8	14.7	85.4	极粗粒度 Extrme- coarse	1700	改进牌号，具有优越的冲击性能及抗热疲劳性能，适用于复杂工况下硬岩巷道掘进、硬岩旋挖齿。 upgrade, With excellent impact resistance and thermal fatigue resistance, fatigue resistance, Suitable for hard rock coal mine drilling and formation rotary drilling.
GD30C	10	14.45	86	超粗 Ultra Coarse	2400	具有良好的韧性及抗热疲劳性能，适用于采矿、采煤机、掘进机用齿和旋挖机用齿。 With excellent toughness and thermal fatigue resistance, Suitable for mining, coal cutting and rotary drilling.
GF50	15	14	87	中 Moderate	3100	高钴牌号，具有良好的韧性和抗弯强度。适用于地质勘探合金 High Co content grade. good toughness and bending strength

工程、建筑用合金齿形 Shapes of Inserts

### 帽状路面铣刨齿 Cap-Shaped Inserts

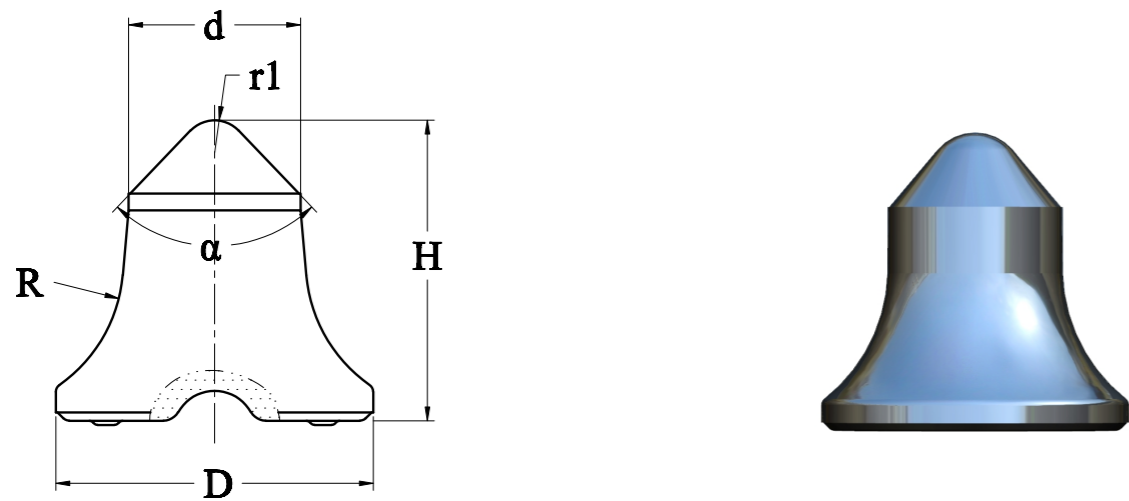

型号 Type	D	H	d
SW31616	16	16.5	7.8
SW31716	17	16	8.5
SW31817	18.4	17.3	10.3
SW31918	19	18	10.3
SW31919	19	19.9	10.5
SW32019	20.5	19	10.6
SW32119	21	19.7	11.8
SW32223	22	23	11.5
SW32926	29	26	19.1

注：可按客户要求规格生产。  
Note: Can be customized according to customer's requirements.

### 帽状路面铣刨齿 Cap-Shaped Inserts

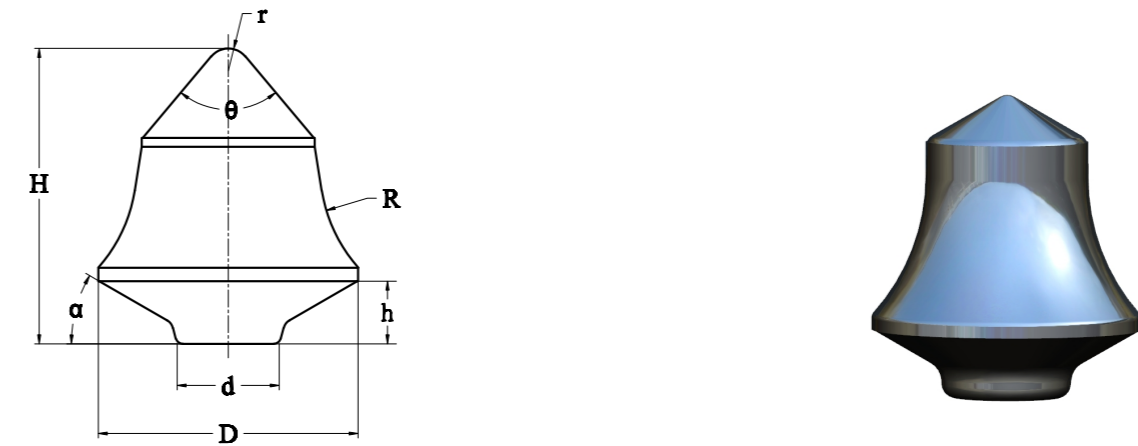

型号 Type	D	H	d
SW41921	19	21.0	11.5
SW42932	29	32.0	19.2

注：可按客户要求规格生产。  
Note: Can be customized according to customer's requirements.

### 柱状路面铣刨齿

Columnar Inserts

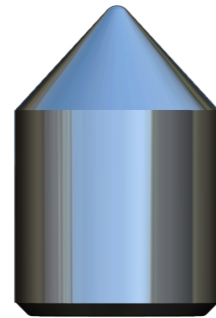
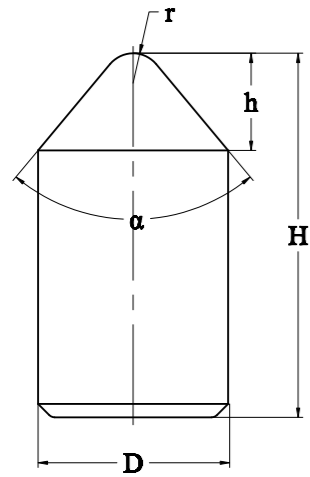

型号 Type	D	H	h
SZ11226	12	26.8	6.8
SZ11324	13	24	6.5
SZ11523	15.2	23	7.7

注：可按客户要求规格生产。  
Note: Can be customized according to customer's requirements.

### 旋挖齿

Rotary Inserts

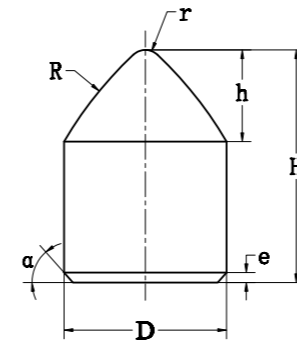

型号 Type	D	H	h	a
SD11926A	19	26	12	45
SD12130	21	30	12	45
SD12234	22	34	12	45

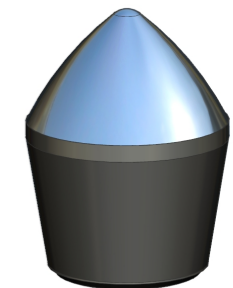
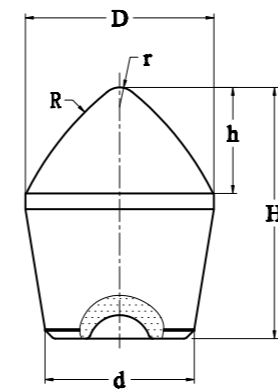

型号 Type	D	H	d	R	r
SD52026	20	26	14	25	3
SD52228	22	28	17	50	2
SD52530	25	30	16	30	3
SD52836	28	36	22	25	5.5

注：可按客户要求规格生产。  
Note: Can be customized according to customer's requirements.

## 地质勘探合金

### Geological Prospecting Inserts

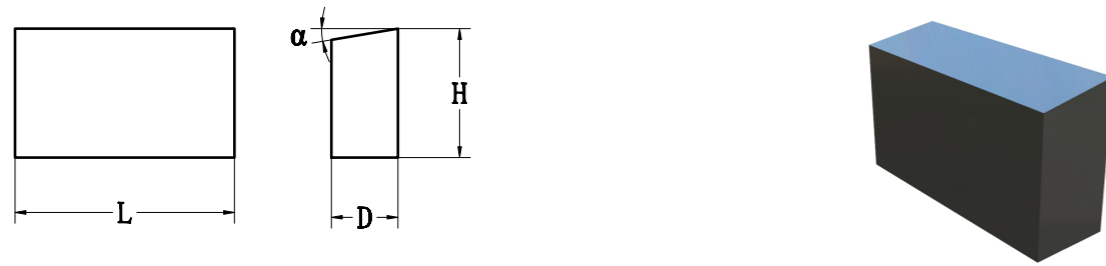

型号 Type	D	H	L
T2230	9	18	30



型号 Type	D	A	H
T3010	10	10	16

注：可按客户要求规格生产。  
Note: Can be customized according to customer's requirements.

## 岩石硬度等级划分

### Rock Hardness Grading

岩石级别 Rock Grade	代表性岩石 Representative Rock
I	最坚固、致密、有韧性的石英岩、玄武岩和其他各种特别坚固的岩石。 The most strong, dense, tough quartzite, basalt and other particularly strong rock (f=20)
II	很坚固的花岗岩、石英斑岩、硅质片岩，较坚固的石英岩，最坚固的砂岩和石灰岩。 Very strong granite, quartz porphyry, siliceous schist, more solid quartzite, the most strong sandstone and limestone. (f=15)
III	致密的花岗岩，很坚固的砂岩和石灰岩，石英矿脉，坚固的砾岩，很坚固的铁矿石。 Dense granite, very strong sandstone and limestone, quartz veins, solid conglomerate, very strong iron ore. (f=10)
IIIa	坚固的砂岩、石灰岩、大理岩、白云岩、黄铁矿，不坚固的花岗岩。 Strong sandstone, limestone, marble, dolomite, pyrite, unstable granite (f=8)
IV	一般的砂岩、铁矿石。 General sandstone, iron ore (f=6)
IVa	砂质页岩，页岩质砂岩。 Sandy shale, shale sandstone (f=5)
V	坚固的泥质页岩，不坚固的砂岩和石灰岩，软砾石。 Rugged shale, unstable sandstone and limestone, soft gravel (f=4)
Va	各种不坚固的页岩，致密的泥灰岩。 A variety of not strong shale, dense marl (f=3)
VI	软弱页岩，很软的石灰岩，白垩，盐岩，石膏，无烟煤，破碎的砂岩和石质土壤。 Soft shale, soft limestone, chalk, salt rock, gypsum, anthracite, broken sandstone and rocky soil. (f=2)
VIa	碎石质土壤，破碎的页岩，粘结成块的砾石、碎石，坚固的煤，硬化的粘土。 Gravelly soil, shattered shale, cemented gravel, gravel, rugged coal, hardened clay (f=1.5)
VII	软致密粘土，较软的烟煤，坚固的冲击土层，粘土质土壤。 Soft-dense clay, soft bituminous coal, solid impact soil, clay soil. (f=1)



### 硬度换算表 Hardness Comparison

布氏硬度10mm球 荷重3000kg			洛氏硬度(3R)				维氏硬度 HV 荷重 30kg
标准球 Standard Ball	Hult Green 球	碳化钨球 Carbide Ball	HRA 荷重60kg 金刚石	HRB 荷重100kg 1/6"球	HRC 荷重150kg 金刚石	HRD 荷重100kg 金刚石	
-	-	-	92.5	-	80.5	-	1700
-	-	-	92.0	-	80.0	-	1600
-	-	-	91.5	-	79.0	-	1550
-	-	-	91.0	-	78.0	-	1500
-	-	-	90.5	-	77.0	-	1450
-	-	-	90.0	-	76.0	-	1400
-	-	-	89.5	-	75.0	-	1350
-	-	-	89.0	-	74.0	-	1300
-	-	-	88.5	-	73.0	-	1250
-	-	-	88.0	-	72.0	-	1200
-	-	-	87.5	-	71.5	-	1150
-	-	-	87.0	-	71.0	-	1140
-	-	-	86.5	-	70.0	-	1076
-	-	-	86.0	-	69.0	-	1004
-	-	-	85.6	-	68.0	76.9	940
-	-	-	85.3	-	67.5	76.5	920
-	-	-	85.0	-	67.0	76.1	900
-	-	767	84.7	-	66.4	75.7	880
-	-	757	84.4	-	65.9	75.3	860
-	-	745	84.1	-	65.3	74.8	840
-	-	733	83.8	-	64.7	74.3	820
-	-	722	83.4	-	64.0	73.8	800
-	-	710	83.0	-	63.3	73.3	780
-	-	698	82.6	-	62.5	72.6	760
-	-	684	82.2	-	61.8	72.1	740
-	-	670	81.8	-	61.0	71.5	720
-	615	656	81.3	-	60.1	70.8	700
-	610	647	81.1	-	59.7	70.5	690
-	603	638	80.8	-	59.2	70.1	680
-	597	630	80.6	-	58.8	69.8	670
-	590	620	80.3	-	58.3	69.4	660
-	585	611	80.0	-	57.8	69.0	650
-	578	601	79.8	-	57.3	68.7	640
-	571	591	79.5	-	56.8	68.3	630

### MEMO

---



---



---



---



---



---



---



---



---



---



---



---



---



---



---



---



---



---



---



---



---



---



---





## 厦门金鹭特种合金有限公司

地址：中国厦门市湖里区兴隆路69号  
工厂地址：中国福建省厦门市集美北部工业区天阳路52-60号  
电话：+86-592-5657886  
传真：+86-592-5657886  
邮编：361006  
电邮：gesac@cxtc.com  
网址：Http://www.gesac.com.cn

## XIAMEN GOLDEN EGRET SPECIAL ALLOY CO.,LTD.

Add: No.69 Xinglong Road Huli Xiamen CHINA  
Factory Add: NO.52-60,North Industrial  
Park,Jimei,Xiamen,Fujian,China  
Tel: +86-592-5657886  
Fax: +86-592-5657886  
PC: 361006  
Email: gesac@cxtc.com  
Http://www.gesac.com.cn



BSC201709a